

P.O. Box 577
Brookshire, Texas 77423
U.S.A



Tel: (281) 375-5515
Fax: (281) 934-1600
west@westengineer.co
m

ISO 9001:2008 Certified

Mr. Dan Stoltz
BP Well Team Leader
200 West Lake Park Blvd.
Houston, TX 77079

26 May 2010

Subject: *Discoverer Enterprise*
Reference: Acceptance of Well Control Equipment

Dear Mr. Dan Stoltz:

Enclosed is the report from our recent assessment of the well control equipment on the *Discoverer Enterprise*. Thank you for using WEST Engineering Services to assist in performance of the well control equipment inspection and acceptance testing.

The cooperation received from the personnel aboard the *Discoverer Enterprise* was most appreciated. Special thanks go to the subsea engineers and TOI Supervisors. Their assistance allowed the testing and assessment to progress smoothly.

The highlights of this assessment include:

- Hydril Casing Shear Ram Bonnet:** While working on the yellow pod, the subsea engineer noticed fluid leaking from the forward casing shear ram bonnet weep hole. No operating pressure was applied to the bonnet. A rebuilt casing shear ram bonnet was delivered to the rig. The rebuilt casing shear ram bonnet operator (open and close) was successfully pressure tested.
- Hydril Annular Preventer:** The Hydril Annuflex annular element was visually inspected by use of the WEST supplied WEST Scope video camera. The camera was run into the bore of the annular and inspected. The result of the inspection was that the annular element is in good condition and does not need to be replaced at this time.
- Moonpool Coflexip Hoses:** The Coflexip type hoses in the moonpool were visually inspected. All hoses in the moonpool were observed to have damage to the outer protective sheath and will need to be replaced. No certification was produced on the rig.

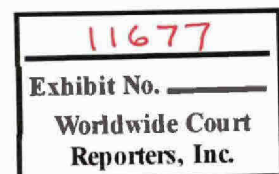

CONFIDENTIAL

BP-HZN-2179MDL07807382

TREX 011677.0001

While conducting this assessment, WEST has made comments and recommendations to assist improving operation of well-control equipment, improving safety and increasing equipment reliability. In conformance with API and ISO recommendations, WEST will follow up these recommendations to ensure their satisfactory resolution. To expedite this process, WEST has included Section 3 in this report.

Should you have any comments on the contents of this report, please do not hesitate to contact us at WEST Engineering Services. It has been a pleasure to serve BP. Your faith in our service is most appreciated.

Best Regards,

P.P.

David Moore/James L Regan

cc: M. Montgomery – WEST

WEST Report #3925

Section 1: Project Summary

Operator: BP
Rig: *Discoverer Enterprise*
Contractor: Transocean
Location: GoM
Water Depth: 5,000 feet
Dates of Assessment: 28 April to 16 May 2010
WEST Representatives: David Moore / James Regan
WEST In-House Technical Review: Gene Nimmo
WEST In-House Administrative Review: Lindsay Skinner

Operator Personnel

Well Site Leaders: Chris Rawson
discover@bp.com
GeorgeWalker
discover@bp.com

Contractor Personnel

Rig Manager: Todd Wilson
todd.wilson@deepwater.com
832-587-8859
OIM: JamesIngram
oim.den@deepwater.com
713-232-8245
Subsea Superintendent: Geoff Boughton
geoff.boughton@deepwater.com
832-587-8535
Subsea Engineers: Brian Gore
srsubsea.den@deepwater.com
PatrickAllen
713-232-232-8245

Section 2: Executive Summary

WEST was requested by BP to go to the *Discoverer Enterprise* to perform an audit of the well control equipment in regards to its fit for purpose condition.

Hydril 18-3/4" 15,000 psi Casing Shear Ram with 22" Operator:

While working on the yellow pod, the subsea engineer noticed fluid leaking from the forward casing shear ram bonnet weep hole. No operating pressure was applied to the bonnet. See Daily Report #11.

A rebuilt casing shear ram bonnet was delivered to the rig. See Daily Report #16. The rebuilt casing shear ram bonnet operator (open and close) was pressure tested to 4,000 psi for five minutes each before the bonnet was installed on the body. The bonnet was then installed on the forward casing shear ram body and bonnet bolts torqued to 2,000 ft/lbs. The 16 each forward casing shear ram operator bolts were replaced as per Hydril Advisory 09-001. The new bolts were installed and torqued to 1,700 ft/lbs using Moly 503 lubricant. The bolts are 1-1/2" x 5-1/2", Hex head, Xylan coated and Inconel 718 precipitation hardened. See Daily Report #17.

The ROV hot stab was connected to the upper blind shear rams and the blind shear rams were closed with 3,000 psi. The forward casing shear ram bonnet was pressured to 200-300 psi for five minutes and 15,000 psi for five minutes. Both tests were successfully charted and witnessed by WEST. See Daily Report #18.

Annular Preventer – Hydril GX Annuflex 18-3/4" 10,000 psi:

The Hydril Annuflex annular element was visually inspected using the WEST scope video camera. The camera was run into the bore of the annular and inspected. The result of the inspection was that the annular element is in good condition and does not need to be replaced at this time. The video of the inspection was given to the subsea engineer. See Daily Report #5.

The annular was wellbore pressure tested to MWP. The annular was closed with 1,500 psi. The annular was then pressure tested to 200-300 psi for five minutes and 10,000 psi for five minutes using a 5" and a 6-5/8" test joint. The inner and outer bleed valves were incorporated into the annular tests. The half-open tool was then installed on both valves and a 250 psi for five minutes and 10,000 psi pressure test was performed. Since the WOM valve seals on the upstream and downstream of the gate the half-open tool keep the valve in the half-open position so the bonnet gasket can be pressure tested. The final test on the LMRP was the annular U seal, the U seal was pressure tested to 2,000 psi for 10 minutes. All pressure tests were successful, charted and witnessed by WEST and MMS. All tests were charted and acceptable. See Daily Report #10.

Moonpool Hoses

The Coflexip type hoses in the moonpool were visually inspected. All hoses in the moonpool were observed to have damage to the outer protective sheath and will need to be replaced. No certification was produced on the rig. See Daily Report #3.

Ram BOPs Hydril 18-3/4" 15,000 psi with MPL

The ram bonnets were opened and the ram rubber goods were visually inspected. All ram packers and top seals were replaced with new rubber goods. See Daily Report #6.

A signature test was performed on the aft middle pipe ram open and close operators. The pressure to open or close should be in the 100-200 psi range. The pressure to open the ram was 380 psi. The MPL was removed from the housing and both locknut bearing replaced. A signature test was performed on the forward upper pipe ram MPL open and close operators. The opening pressure was recorded at 435 psi. The MPL was removed from the housing and both locknut bearing replaced. A signature test was performed on the lower blind shear rams, the pressure recorded to open the rams was 80 psi and the closing pressure was 80 psi. The signature test pressures were acceptable. A signature test was performed on the upper blind shear rams, the pressure recorded to open the rams was 125 psi and the closing pressure was 120 psi. The signature test pressures were acceptable. See Daily Report #5.

The BOP stack was wellbore pressure tested to MWP. The upper and middle HVR (Hydril Variable Rams) 4-1/2" x 7" were wellbore pressure tested to 200-300 psi for five minutes and 15,000 psi for five minutes using a 5" and a 6-5/8" test joint. The rams were closed with 1,500 psi with the MPL engaged and then the rams were put in the block position to vent off the closing pressure. All tests were charted and acceptable. The subsea valves were incorporated into the ram wellbore pressure testing. Before testing, the subsea valves were opened with 1,500 psi and then the valves were put in the block position and closed on spring tension only and tested to 200-300 psi and 15,000 psi. The lower outer kill valve did not fully close on spring tension, therefore would not hold a pressure test. The valve operator was removed and replaced with a spare valve operator. See Daily Report #10.

The lower 9-5/8" casing rams were wellbore pressure tested. A 9-5/8" test joint was lowered into the wellbore. The 9-5/8" casing rams were closed with 1,500 psi and the MPL engaged. Once the locks were engaged the 1,500 psi closing pressure was vented to 0 psi. The low pressure applied was 200-300 psi and the high pressure was 15,000 psi. The charts were reviewed and acceptable. The upper blind shear rams and lower blind shear rams were wellbore pressure tested. The BSR's were closed with 1,500 psi and the MPL engaged. Once the locks were engaged the 1,500 psi closing pressure was vented to 0 psi. The low pressure applied was 200-300 psi and the high pressure was 15,000 psi. The charts were reviewed and acceptable. See Daily Report #11 and #18.

Subsea Valves WOM 3-1/16" 15,000 psi:

All subsea valves were greased with Magnaseal grease before testing. During the pressure testing of the WOM subsea valves, all valve cavities were pressure tested as per the manufacture's procedure with the valve gate in mid stroke; this is part of the Transocean pressure testing procedure.

The lower outer kill valve did not fully close on spring tension, therefore would not hold a pressure test. See Daily Report #10. A rebuilt lower outer kill subsea valve operator was installed on the body. The operator (open and close) was pressure tested to 3,000 psi for five minutes each before the operator was installed on the body. 1,500 psi opening pressure will be applied to the operator and then the pressure bled off allowing the spring to close the valve. The valve gate was wellbore pressure tested to 200-300 psi for five minutes and 15,000 psi for five minutes. See Daily Report #16.

Controls Cameron Mark II Control System:

WEST performed a visual inspection of the BOP HPU. It was noted that the pressure relief valves on the unit did not have certification tags installed on the valves. It is recommended that the pressure relief valves are recertified or replaced. The surface mounted accumulator bottles were observed to be in good condition. A visual inspection was performed on the BOP high pressure test unit. It was noted the pressure gauges did not have a calibration date sticker affixed. See Daily Report #2.

The subsea engineer performed a mode 1 EDS. A mode 1 EDS is selected when there is no pipe in the hole. The lower shear rams are closed, the riser connector is unlocked, the pod stingers are retracted and the seals are de-energized and all stack functions go to the block position. The blue pod SEM A was selected and the BOP stack functions were put into the drilling mode. Once the EDS was selected a total of 28 gallons was used and the total time to operate was 25 seconds. EDS mode 1 was successfully performed from the blue pod SEM A.

A mode 2 EDS was attempted. A mode 2 EDS is selected under normal drilling operations. The casing shear rams are closed, the upper blind shear rams are closed, the riser connector is unlocked and the pod stingers are retracted and the seals are de-energized and all stack functions go to the block position. During the EDS, fluid was observed coming out of the tattle-tale port on the forward casing shear ram bonnet. The piston seals were leaking. The subsea engineer shut down the EDS and is in the process of procuring the proper seal kit to be installed.

Further testing of the control system EDS functions (Mode #2 – Casing & Upper Shear Ram) revealed that the casing shear ram high pressure function would not operate, troubleshooting indicated that the quarter inch pod valve in the yellow control pod was faulty, the valve was changed and testing continued. The casing shear ram still would not function whilst in Mode #2. Further troubleshooting was ongoing which included the inspection of the HP casing shear close SPM. EDS Mode #2 sequence time log, the LMRP unlatched at +/- 34 Seconds using 28Gls total time used to complete the EDS sequence was 44 seconds. See Daily Report #3.

The 5,000 psi to 4,000 psi HP casing shear ram regulator was removed from the BOP stack due to leaking seals. A repair kit or replacement regulator was not found on the rig. TOI attempted to source a repair kit or another regulator from the TOI fleet to no avail. The leaking regulator was installed back on the BOP stack so function testing and wellbore testing can proceed. WEST was informed that Hydril had sent out the wrong 5,000 psi to 4,000 psi regulator repair kit. The repair kit sent out was P/N 313444-RK, the correct repair kit P/N is 3137445-RK. The subsea engineer will contact Hydril and have the proper repair kit sent out. See Daily Report #18.

Wellhead Connector Cameron HC Connector 18-3/4" 15,000 psi

The Vetco H-4 wellhead connector was removed from the stack due to BP requirements. A new Cameron HC Collet Connector was sent to the rig to be installed. The new HC collet connector was positioned in the moon pool in order to carry out pre installation operator pressure tests. The pressure tests failed and a new connector was sourced. See Daily Report #4. The Cameron HC Collet connector was removed from the set back area and prepared to be disassembled by the OEM, Cameron. Cameron determined that the connector had to be sent to their shop to be properly repaired. See Daily Report #5.

The new Cameron Collet Connector was delivered to the rig. Once on the rig the connector operators were hydraulically pressure tested. The latch, unlatch and secondary unlatch ports were pressure tested to 3,000 psi for 10 minutes each. All tests were acceptable. The BOP stack was skidded over the

connector and a new CX gasket was installed. The connector was raised onto the lower triple BOP flange. The studs were coated with Moly 503 and the nuts were torqued to 7,620 ft/lbs. See Daily Report #6. The new connector information was as follows:

18-3/4" 15k Cameron HC Collet Connector

P/N 615626-05

S/N 96-1237237-10

Attachments:

- A. *Discoverer Enterprise* Stack Drawing
- B. Hydril GX Annular BOP Drawing
- C. Hydril Ram BOP Drawing
- D. WOM Subsea Valve Drawing
- E. Cameron HC Wellhead Connector

**Discoverer Enterprise
18 3/4" 15K BOP STACK**

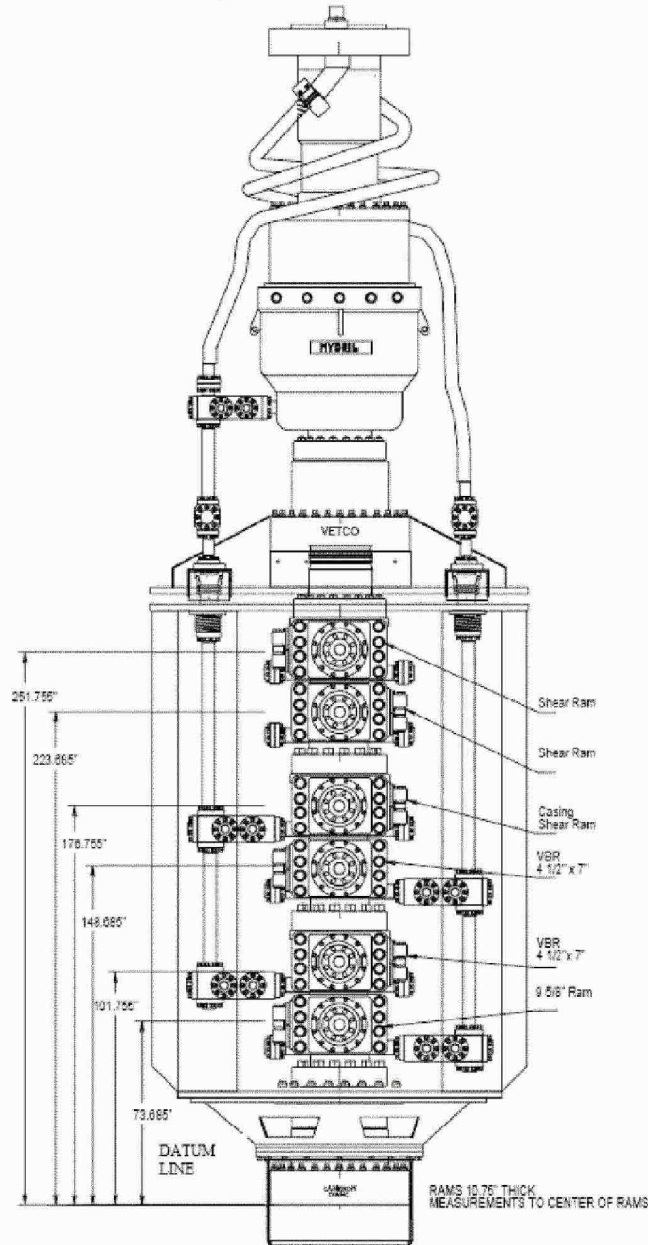

EQUIPMENT LIST

Flex Joint:	Hydril	Riser:	Vetco HMF 21"
Annular:	Hydril GX 10K	Telescoping Joint:	Vetco
LMRP Connector:	Vetco 15K HAR	Ram BOPs:	Hydril "Compact" 15K
Subsea Valves:	WOM 3-1/16" 15K	Wellhead Connector:	Cameron DWHC 15K
Control System:	Cameron MUX, Modular	Diverters:	Vetco CSO

Hydril GX Annular BOP

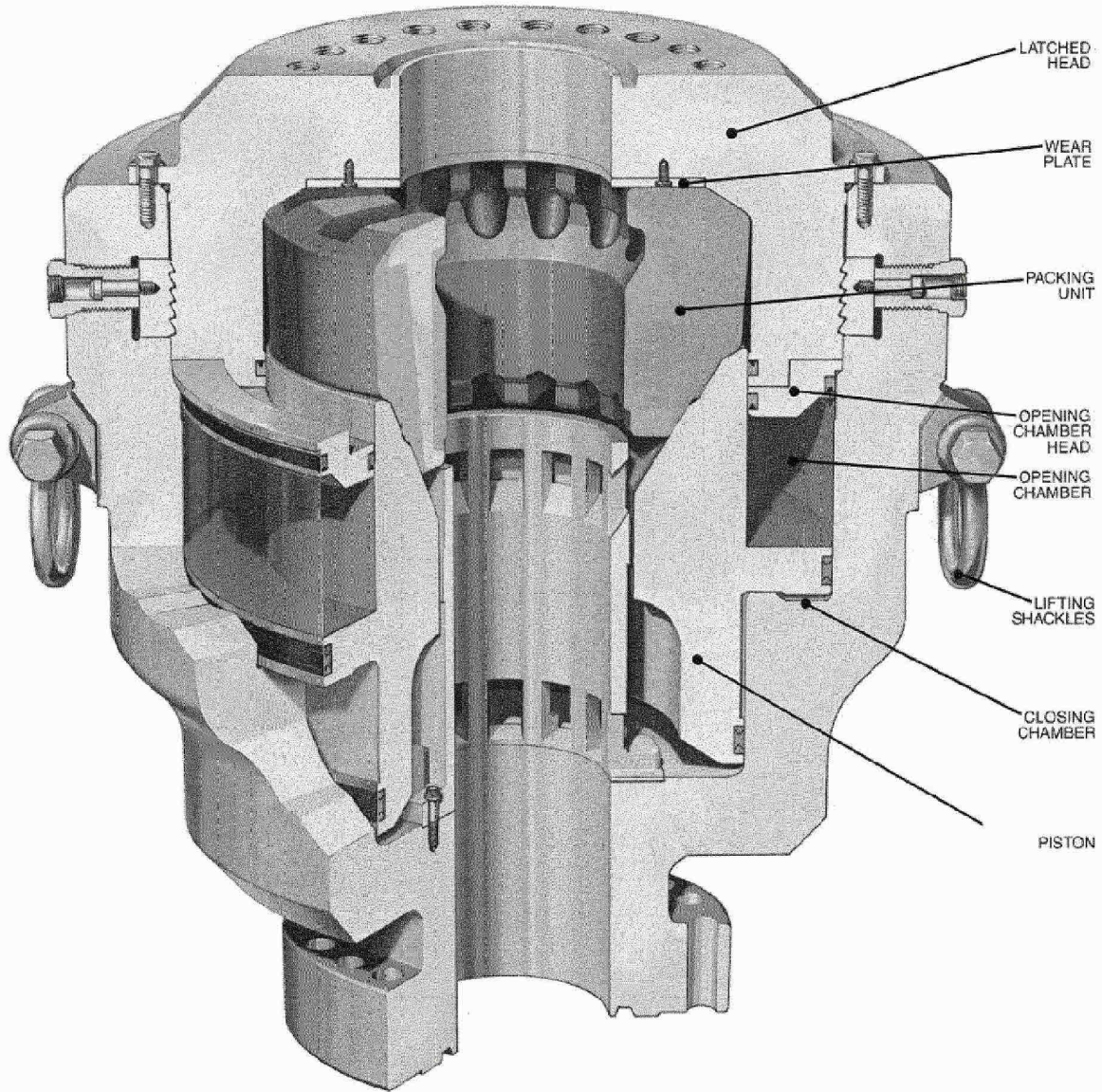

Hydril Compact Ram BOP
18-3/4" 15,000 psi

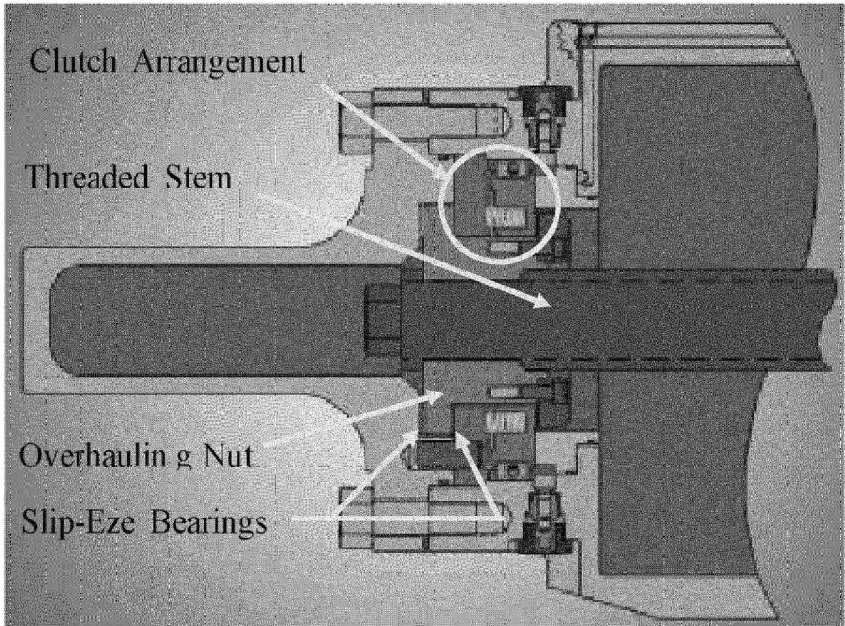
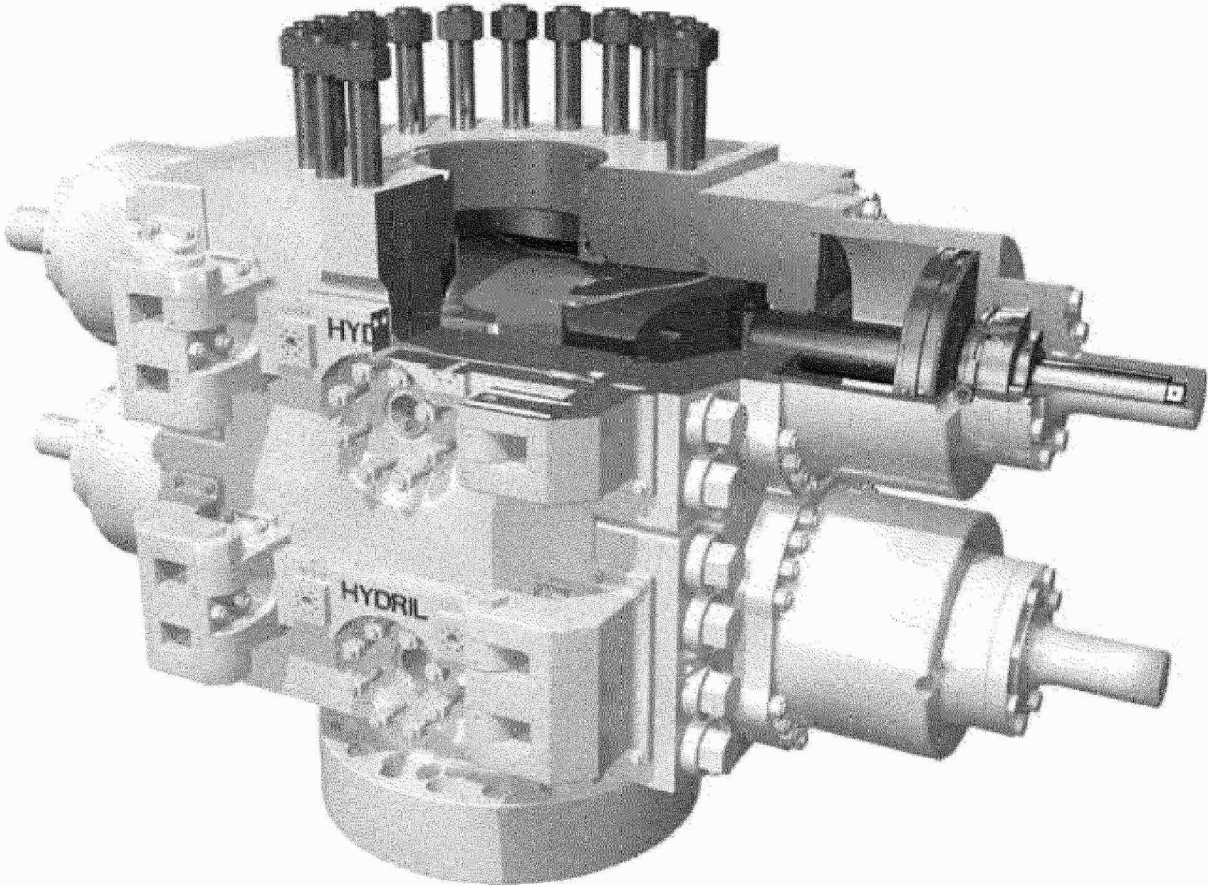

MPL

WOM Subsea Valve

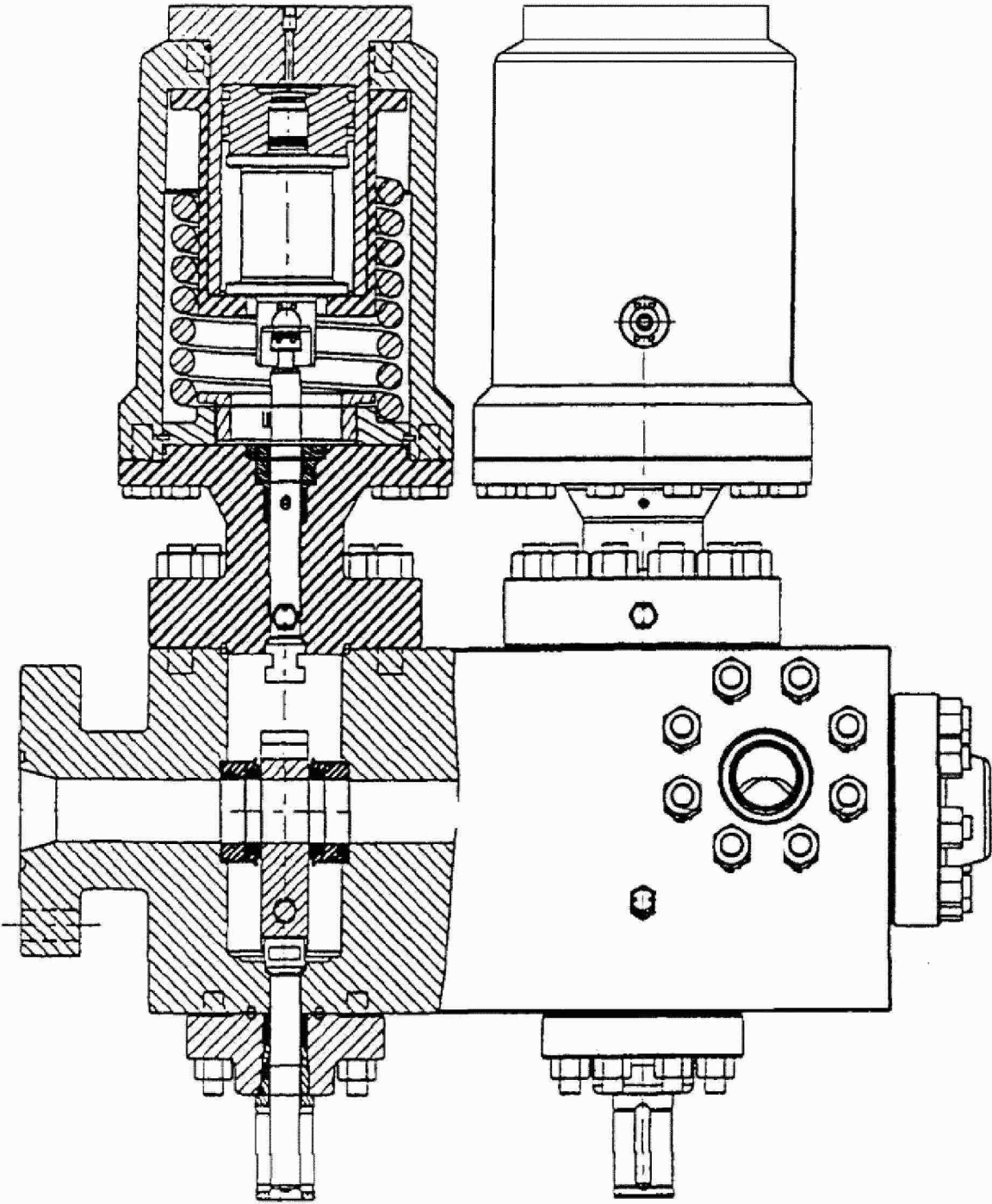

Cameron Model HC Connector

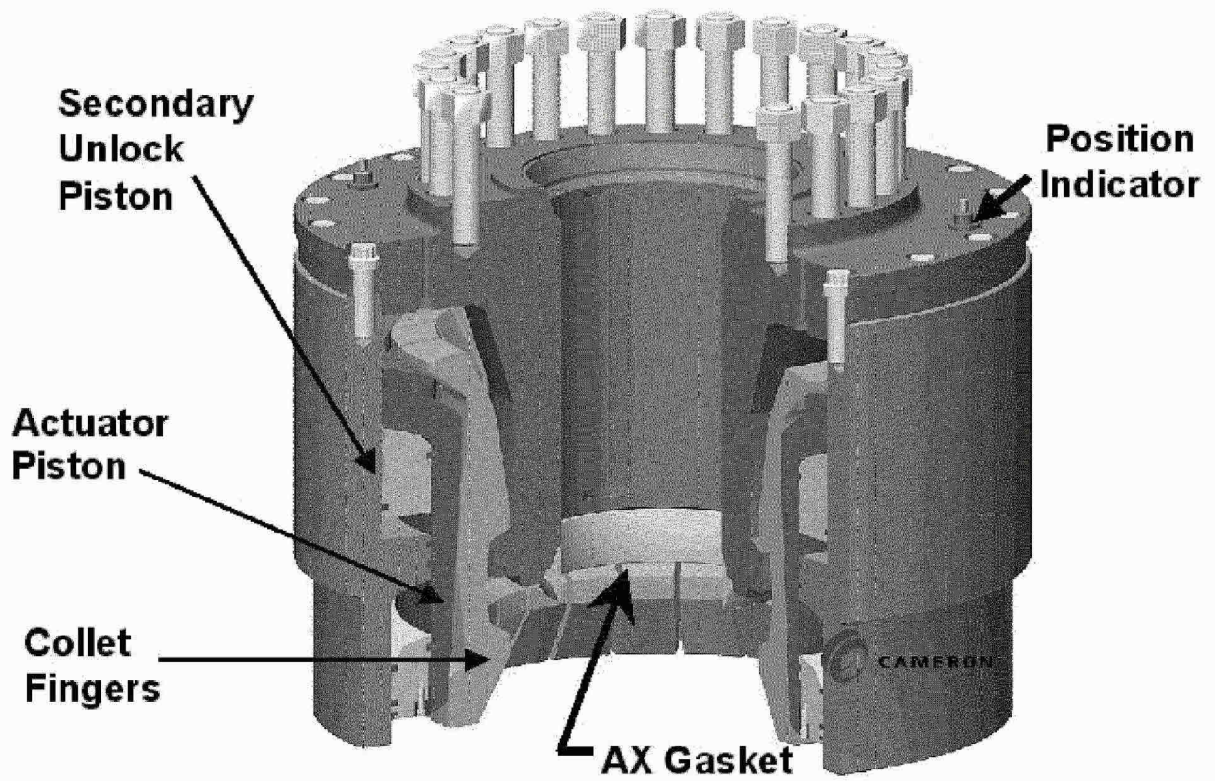

Section 3: WEST Recommendation Summary and Disposition
Discoverer Enterprise, Job #3925; 27 April to 16 May 2010
Prepared for BP

Revision 1

Purpose:

During the assessment process, WEST makes various comments and recommendations aimed towards improving safety and increasing equipment reliability. In conformance with API and ISO standards, WEST follows up on these recommendations to ensure their satisfactory resolution. To expedite this process, WEST maintains this living document that is updated during each assessment. This allows WEST to effectively manage the recommendations so the same issues are not repeated once a satisfactory resolution is in place. Any time the status changes or comments are added, the results should be forwarded to WEST so the master file can be updated. The definitions used for each recommendation priority level are as follows:

- Priority I:** Critical items that have a significant risk of failure, well control event and/or personnel injury, and must be corrected immediately. Customer will be notified of any Priority I issues by the surveyor's technical supervisor in WEST's main office.
- Priority II:** Major items that have a significant risk of causing downtime or lowering safety and should be completed within the next six months or three wells. In many cases, these items are critical to long-term equipment reliability.
- Priority III:** Minor items that relate primarily to regulations, rig management, quality assurance issues and good oilfield practice. As these issues are unrelated to existing equipment condition, they have a low level of risk. These should be completed as soon as time permits.

Item No	Priority	Recommendation	Class	Reference				Comments/Status	Date		
				Job #	Surveyor Initials	ATP	Daily Report		Opened	Closed	Estimated Completion
1	II	A Hydril service technician is to be dispatched to the rig and inspect the leaking forward casing shear ram bonnet rod seals. It is recommended that TOI ensure that a Red spare bonnet and spare seals are available and can be sent to the rig if needed.	BOP-Rams	3925	DM		DR 12		May-10	10	
2	II	It is recommended that the rig wellbore pressure test the ram type preventers on the surface with locks only applied and no closing pressure. Reference API RP 53, 3rd Edition, Section 11.8.5.9	BOP-Rams	3794	JR	ATP 82 & 494		Not tested on locks; discussed with BP company representative prior to the stump test. JR Dec-09 Rams wellbore pressure tested using locks only. DM May-10	Dec-09	May-10	
3	III	While making repairs on the BOP, it was noted that two bolt heads were broken off on the forward casing shear ram cylinder head hydraulic operating chambers which open and close the rams. WEST recommended for the rig to send the Hydraulic cylinder head bolts, Hydril p/n 1931227-2000 to an independent party to determine the hardness and cause of the failures. If il	BOP-Rams	3614	LA		DR 2	No action. DM May-10	Sep-09		
4	III	It is recommended for a third party to repair the damaged threads in the forward casing shear cylinder head.	BOP-Rams	3614	LA		DR 4	The damaged threads have been repaired. DM May-10	Sep-09	May-10	

Item No	Priority	Recommendation	Class	Reference			Comments/Status	Date			
				Job #	Surveyor initials	ATP		Daily Report	Opened	Closed	Estimated Completion
5	III	Transocean should work with Hydral to determine the acceptance criteria for measuring the ram cavity height. Specifically the gap under the lower wear plate has a direct affect on the cavity dimension but this issue is not addressed in the operator's manual for the ram BOPs. Therefore measurements could indicate the ram cavity is acceptable when in fact the extrusion gap is too big.	BOP-Rams	1720	LS		DR 7	Hydral service hand measured the ram cavity and ram blocks. Still there were some discrepancies. See Job #2164 DR #9 Attachment #1. Still need a procedure. GE Apr-06 No comment from the senior subsea engineer. MG Sept-06 No change in status. AB Mar-07 No action. DM May-10	Jul-04		
6		Source a replacement Cameron HC Collet Connector as a back up and supply a replacement seal kit to rebuild the HC Collet Connector which failed its operator circuit tests.	Connectors	3925	JR		DR 4	A replacement connector was sourced and delivered to the rig. The leaking connector is being rebuilt on the rig. DM May-10 g	May-10	May-10	y
7	II	It was noted that during function testing that the wellhead connector gasket retainer pin pilot line was blocked. It is recommended that the pilot lines are made functional or the pilot lines replaced.	Connectors	3794	JR	ATP 149		Gasket retainer pins pilot line blocked. gasket will be ran with ROV. JR Dec-09	Dec-09	09	
8	II	WEST performed a visual inspection of the BOP-HPC. It was noted that the pressure relief valves on the unit did not have certification tags installed on the valves. It is recommended that the pressure relief valves are recertified or replaced. Reference API RP 16D, 2nd Edition, Section 5.1.2.3. API RP 53, 3rd Edition, Section 13.4.4. API RP 64, 2nd Edition, Section 5.8.5.2	Controls	3925	DM	ATP 212, 218	DR 2			May-10	
9	II	The 5k to 4k HP casing shear ram regulator was removed from the BOP stack due to leaking seals. The leaking regulator was installed back on the BOP stack so function testing and wellbore testing can proceed. It is recommended that once a repair kit is sourced and sent to the rig the regulator will be rebuilt and gested.	Controls	3925	DM	ATP 222	DR 7			May-10	
10	II	It is recommended that the ROV panels mounted on the BOP stack and LMRP are function and wellbore pressure tested after actuating the function. Reference MMS Safety Alert No. 186.	Controls	3925	DM	ATP 201, 272	MM 1			May-10	
11	II	It is recommended that flow restrictors be installed in the function lines between the pods and shuttle valves on control systems having a conduit or accumulator supply pressure greater than 3,000 psi. Reference Anomaly M-C-23.	Controls	3925	DM	ATP 280		No flow restrictors are installed. DM May-10	May-10		
12	II	It is recommended that the BOP and control system be function tested from the drillers and toolpushers control panels. These functions can be dry fired. Reference WEST ITP #128, MUX Controls Between Well Maintenance Checklist.	Controls	3925	DM	ATP 297		Not function tested from drillers or toolpushers control panels. We were informed that this would be done. DM May-10	May-10	10	
13	III	The hotline hose reel panel was observed to have a cracked gauge face. The gauge will need to be replaced when the BOP is on deck.	Controls	3925	DM		DR 2			May-10	
14	III	If the control system has a hydraulic conduit, the flexible hydraulic hose in the moonpool, including end connections, should be flame retardant. All moonpool hoses outer jackets are damaged and the hoses should be replaced.	Controls	3925	DM	ATP 278		All moonpool hoses outer jackets are damaged and the hoses should be replaced. DM May-10	May-10		g
15	III	It is recommended wellbore pressure tests be done following an ROV panel function test.	Controls	3925	DM	ATP 201		Wellbore pressure tests not performed after EDS or deadman. Wellbore pressure tests should be done following an ROV panel function test. DM May-10	May-10		

Item No	Priority	Recommendation	Class	Reference				Comments/Status	Date		
				Job #	Surveyor Initials	ATP	Daily Report		Opened	Closed	Estimated Completion
15	III	As part of the between well maintenance on the spare pod, pilot lines which dead end should be flushed. Transocean may also consider installing gauge protectors (snubbers) to prevent trash from plugging the electronic components. Additionally, if the snubbers did get plugged they could quickly be serviced without opening the subsea modules.	Controls	1720	LS		DR 20	No action to date. GE Apr-06 Snubbers installed on the current spare pod MG Sep-06 Snubbers installed in two pods. Third pod to be done this survey. AB Mar-07 No change. DM May-10	Aug-04		
17	II	It was noted that the moonpool hoses did not have safety slings installed. It is recommended that safety slings be installed from the rig hard piping to the Colflexip type hoses. Reference IADC Safety Alert 00-24.	Mud System	3925	DM	APT 182	DR 3		May-10		
18	III	It was noted that the colmonoy coating was flaked off on the outboard side of the male choke stack on the E.MRP. It is recommended for the rig to send the damaged Hydril stack, p/n 3120900, to Hydril to determine cause of failure.	Mud System	3614	JA		DR 1 and 2		Sep-09		
19	III	Transocean should consider changing the choke and kill drupe hoses at the next convenient time. Hoses were installed in June 2003 and two in August 2009. Reference API RP 53, 3rd edition, section 18.10.2 and MMS CFR Title 30, Chapter II, Section 250.406 Paragraph (a).	Mud System	3479	RM	ATP 148	DR 5	All moonpool hoses outer jackets are damaged and the hoses should be replaced. DM May-10	Jun-09		
20	III	Goose neck side conduit line hose outer sheathing is starting to unravel. At next available date, recommend installing new conduit hose and send current one in for repair. The current conduit hose was installed G-12-06 and was a Copper States SK. Consider installing another brand such as Colflexip for longer durability.	Mud System	2164	GE		DR 14	No action. MG Sep-06 No action taken yet due to long lead time on new hoses. AB Mar-07 No action taken. RM Jun-09 No action taken. DM May-10	Apr-06		
21	II	A visual inspection was performed on the BOP high pressure test unit. It was noted the pressure gauges did not have a calibration date sticker affixed. It is recommended that the pressure gauges be recertified or replaced. Reference MMS CFR Title 30, Chapter II, Section 250.402, Paragraph (c); API RP 53, 3rd Edition, Sections 13.38 and 13.9.9; API Spec 16A 5th Edition, Section 3.2.2.	Operational Management	3925	DM	ATP 42	DR 2	A visual inspection was performed on the BOP high pressure test unit. It was noted the pressure gauges did not have a calibration date sticker affixed. DM May-10	May-10		
22	II	The Colflexip type hoses in the moonpool were visually inspected. All hoses in the moonpool were observed to have damage to the outer protective sheath. It is recommended that all moonpool Colflexip type hoses are replaced as soon as practical. Reference API RP 53, 3rd Edition, Section 18.10.2 MMS CFR Title 30, Chapter II, Section 250.406 Paragraph (a).	Operational Management	3925	DM	ATP 180	DR 3		May-10		
22	II	It is recommended that all operators on the BOP stack that have not been hydraulically pressure tested within the last six months are pressure tested.	Operational Management	3925	DM	ATP 80			May-10		
23	II	It is recommended that the hot stabs be tested during the stump test to ensure no operability problems exist and once the functions are closed using the hot stabs a wellbore pressure test to MWP be performed. Reference API RP 53, 3rd Edition, Section 18.3.11; WEST ITP #169; Secondary Intervention; MMS NTL.	Operational Management	3925	DM	ATP 520, 521		The hot stabs were in the process of being tested when WEST departed the rig. DM May-10	May-10		
23	II	It is recommended that after the final annular pressure test the complete BOP stack is drift tested. Reference API Spec 16A, Section 8.5.8.4	Operational Management	3784	JR	ATP 50		Will be drifted after final annular pressure test. JR Dec-09 The BOP stack was not drift tested. DM May-10	Dec-09		

Item No.	Priority	Recommendation	Class	Reference				Comments/Status	Date		
				Job #	Surveys initials	ATP	Daily Report		Opened	Closed	Estimated Completion
24	II	It is recommended that the connections broken in the last six months be re-tightened to prove prepad accuracy. Reference MMS CFR Titley90, Chapter II, Section 250-446, Paragraph(a), API RP 53,(3rd Edition, Section 18.11.2 .	Operational Management	3794 ¹	JR	ATP 55		Will be re-tightened after final pressure test. Lower choke and kill isolation valve. JR Dec-09 All connections broken in the last six months were re-torqued. DM May-10	Dec-09	May-10	
25	III	WEST recommends ensuring the BOP test chart recorder is recalibrated at the next opportunity.	Operational Management	3794	JR		DR 7	The chart recorder was recently calibrated. The due date is 12-10-10. DM May-10	Dec-09	May-10	
26	III	It is recommended for the rig to increase the stock supplies for the choke/kill stab seals. Hydril p/n 3120880 for bore seal kits, minimum two sets or stock two each, Hydril p/n 1920055-234. Modular bearing and four each, Hydril p/n 1920115-238. PolyPac seals.	Operational Management	3614	LA		DR 1		Sep-09		
27	III	WEST recommends increasing the inventory of torquing tools and parts required for BOP maintenance i.e. wrenches and sockets and powerpaks. e. e s	Operational Management	3614 ¹	LX		DR 4		Sep-09		
28	III	The chart recorder on the BOP test unit is overdue for calibration. Also, the calibration stickers on the low and high pressure gauges are illegible. These gauges and the chart recorder should be recalibrated at the earliest opportunity. Reference API RP 53, 3rd edition, section 13.3.8, Accumulator Valves, Fittings, and Pressure Gauges and 13.9.3.g.	Operational Management	2514	AB	ATP 37	DR 7	No change RM Jun-09 The chart recorder has been calibrated but the gauges have not. DM May-10	Mar-07		
29	III	Transocean should request Hydril to provide the necessary corrections for Figure 7-1 in the Dual Compact Ram BOP operator's manual. Figure 7-1 incorrectly shows dimension "A" to be taken at the shortest part of the ram block rather than the tallest. Reference WEST ITP 19, Rev. 15, Hydril Ram Preventer - page 5.	Operational Management	1720 ¹	LS		DR 6	No action to date. Apr-06 GE No action. MG Sept-06 No action to date. AB Mar-07 No action. RM Jun-09 No action. DM May-10	Jul-04		
30	III	The riser on deck was spot checked. Several buoyancy module thrust collars were found to be bent and will need to be repaired or replaced, the thrust collar nuts and bolts were found to be corroded and will need to be replaced.	Riser System	3925	DM		DR 3		May-10		
31	III	Several riser buoyancy modules were observed to be damaged, it is recommended that these damaged modules be repaired.	Riser System	3925	DM		DR 3		May-10		
32	III	It is recommended to inspect riser buoyancy, if used, to ensure that it is not damaged, is securely attached, and the thrust collars are properly installed. Ensure guidance is sufficient to prevent damage when going through the rotary.	Riser System	3925	DM	ATP 359		Riser was visually inspected and damaged buoyancy modules were observed. Damaged thrust collars were also observed. DM May-10	May-10		
33	III	Transocean should consider instituting procedural controls to ensure the tensioners are not incorrectly pressurized should a power failure occur, either during maintenance or routine operations. Another option would be to modify the riser tensioner control system. Riser tensioner control systems with remote operated air pressure vessel (APV) isolation valves that "fail to last position" if control air or power is lost would be preferred. Conversely, the increase pressure and decrease pressure control valves should "fail to last" upon loss of power or control air.	Riser System	1625	MN			No action to date. Transocean engineering dept should review. Current system has valves installed that "fail open" if power is lost to the system. RM Jul-04 No action. GE Apr-06 No action. AB Mar-07 No action. RM Jun-09 No action. DM May-10	Dec-03		

Item No.	Priority	Recommendation	Class	Reference				Comments/Status	Date		
				Job #	Surgeon initials	ATP	Daily Report		Opened	Closed	Estimated Completion
34	III	Transocean should consider repairing and adjusting riser thrust collars on the ABB Vetro riser.	Riser System	1625	MN			Ongoing. MG Sept-06 Still ongoing. AB Mar-07 New thrust collars onboard the <i>Enterprise</i> . RM Jun-09 Action. DM May-10	Dec-03		
35	II	It is recommended that Transocean verify that all stack mounted failsafe valves be disassembled and inspected on a maximum 24 month schedule.	Valves	3925	DM	ATP 157, 162			May-10	10	
35	II	The lower outer kill would not fully close on spring tension alone. It is recommended that the valve actuator is disassembled and checked for the spring if broken. Reference MMS CFR 30 section 250.406 (a), API RP 53, 3rd Edition, Section 18.2.4	kill Valves	3925	DM	ATP 504		The lower outer kill would not fully close on spring tension alone. DM May-10	May-10		

P.O. Box 577
Brookshire, TX 77423
U.S.A



Tel: (281) 934-1500
Fax: (281) 934-1600
west@westengineer.com

ISO 9001:2008 Certified

ATP Application Rev. 1.0.0.20
4/26/2010
SB/ed
ATP Database Rev. 18

Company: BP
Subject: Well Control System Acceptance Testing Procedure
Rig Name: Discoverer Enterprise
Reference: Drill Through Equipment and Related Systems
Rig Type: Drillship - Gulf of Mexico
Job #392 5

Status Codes

C	=	Item Checked and in compliance
X	=	Not in compliance, high risk of downtime
/	=	Not in compliance, low risk of downtime
O	=	Item Not Checked
N/A	=	Item Not Applicable

Inspection Method Codes

T	=	Yes
V	=	Visual Inspection
D	=	Documentation Review
I	=	Interview

Note: Items that are found "Not in Compliance" are appropriately addressed in the Summary of Recommendations

WEST ©

References

for

BOP System Acceptance Testing Procedure (ATP)

The latest revision or edition of each of the following will be used as applicable.

BOP and Diverter SystemsAPI RP 53 *Blowout Prevention Equipment Systems for Drilling Operations*API RP 64 *Diverter Systems Equipment and Operations*API Spec 6A *Wellhead and Christmas Tree Equipment*API Spec 16A *Drill Through Equipment*API Spec 16C *Choke and Kill Systems*API Spec 16D *Control Systems for Drilling Well Control Equipment***Marine Drilling Riser**API RP 16Q *Design, Selection, Operation and Maintenance of Marine Drilling Riser Systems*API Spec 16R *Marine Drilling Riser Couplings***Electrical Equipment**API RP 14F *Design and Installation of Electrical Systems for Fixed and Floating Offshore Petroleum Facilities for Unclassified and Class 1, Division 1 and Division 2 Locations*API RP 500 *Recommended Practice for Classification of Locations for Electrical Installations at Petroleum Facilities Classified as Class 1, Division 1 and Division 2***Safety**API RP 75 *Development of a Safety and Environmental Management Program for Outer Continental Shelf Operations and Facilities***Pressure Vessels**API 510 *Pressure Vessel Inspection Code: Maintenance, Inspection, Rating, Repair, and Alteration*API Spec 576 *Inspection of Pressure-Relieving Devices***Industry Standards**NACE MR0175 *Sulfide Stress Cracking Resistant Metallic Materials for Oilfield Equipment*

ANSI - American National Standards Institute

IADC *Deepwater Well Control Guidelines*

ISA - Instrument Society of America

NEC - National Electric Code

Well Control when Drilling Deep Wells – publication

Regulatory

U.S. Minerals Management Service, Code of Federal Regulations, Title 30 Chapter II Part 250

Coast Guard/DOT CFR 46 Chapter I

Section 61.10-5

CNOSPB - Canada-Nova Scotia Offshore Petroleum Board Regulations

Australian Petroleum (Submerged Lands) Acts {AP(SL)A} Schedule, Specific Requirements

Norwegian Petroleum Directorate Guidelines

Additional**RigLORE**

Manufacturer's Engineering or Technical Bulletins

WEST ITPs (Inspection and Test Procedure)

WEST Information Systems

ITPs

- Base documents for WEST
- Contain equipment information not included in manufacturers' published information
- Highlight information for surveyors to reference from ATP
- Supports anomalies and EBs

ATPs

- Auditable document
- Relies heavily on the technical content of the ITPs
- Auditable points are extracted from Anomalies and refer to the anomaly number for additional supporting information
- Also refers to manufacturers' information in manuals or in RigLore

Anomalies

- Records equipment failures due to manufacturers' defects
- Reference ITPs and manufacturers' documents

RigLore

- A collection of Engineering Bulletins, Product Alerts, Safety Alerts, Product Information Bulletins, IADC and regulatory documents that are used for reference

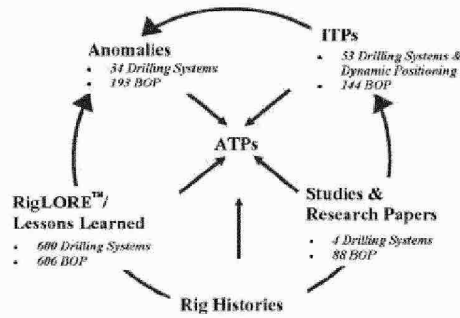

Arrow signifies "supports". The ATPs are the center of the WEST Information Systems and are supported by the Anomalies, ITPs and RigLore.

Table of Contents

	Line Item
Table I - Equipment List & 3-5 Year Survey Status	
Table II - Flexible Hoses	
Section E.1: Operational Management.....	1
E.1.1: Entry/Exit Meetings.....	2
E.1.1.1: Safety.....	17
E.1.1.2: Documentation.....	20
E.1.2: Written Requirements.....	22
E.1.3: Planned Preventive Maintenance.....	25
E.1.4: Operations & Maintenance Manuals.....	33
E.1.5: Replacement Parts.....	36
E.1.6: Quality Management.....	40
Section E.2: BOP Stack Inspection.....	49
E.2.1: End Connections and Side Outlets.....	51
E.2.2: Ram BOPs.....	67
E.2.2.1: Hydril BOPs.....	90
E.2.3: Annular BOPs.....	106
E.2.3.1: Hydril GX Annulars.....	110
E.2.4: Connectors.....	113
E.2.4.1: LMRP Connector.....	119
E.2.4.1.1: Vetco HAR H-4 Connectors.....	121
E.2.4.1.2: Vetco Test Stumps.....	129
E.2.4.2: Wellhead Connector.....	134
E.2.4.2.1: Cameron DWHC Connectors.....	147
E.2.6: Valves.....	156
E.2.6.1: WOM Failsafe Valves.....	167
E.2.7: Choke and Kill Lines and Hoses.....	175
E.2.8: BOP Handling System.....	184
E.2.8.1: Gantry Crane.....	188
Section E.3: BOP Control System.....	195
E.3.1: Documentation & Procedures.....	196
E.3.2: Pumping & Storage Equipment.....	203
E.3.3: Pressure Vessels and Pressure Relieving Devices.....	214
E.3.4: Regulators.....	219

E.3.5: Reaction Times.....	223
E.3.6: BOP Stack Hosing.....	225
E.3.7: Control Panels.....	231
E.3.8: Alarms.....	244
E.3.9: Reel Structure and Drive.....	246
E.3.10: Secondary Intervention Systems.....	262
E.3.10.1: ROV (Remote Operated Vehicles).....	267
E.3.10.2: Automatic Intervention.....	273
E.3.11: Control System - General.....	276
Multiplex Controls.....	279
E.3.11.1: MUX Cables and Connections.....	298
E.3.11.2: Cameron Multiplex Controls.....	305
E.3.12: Subsea TV.....	327
Section E.4: Marine Riser System.....	331
E.4.1: Documentation, Procedures and Inspections.....	332
E.4.2: Telescopic Joint.....	336
E.4.2.1: Vetco HMF Telescopic Joint.....	342
E.4.3: Drilling Riser.....	353
E.4.3.1: Vetco HMF Riser.....	369
E.4.3.1.1: Vetco SLS Tension Ring.....	382
E.4.4: Auxiliary Lines.....	389
E.4.5: Flex Joint, Keyseating and Rig Positioning Equipment (Flex Joint and Ball Joint).....	393
Section E.5: Mud Flow Network.....	398
E.5.1: Choke and Kill Manifold.....	399
E.5.2: Diverter.....	409
E.5.2.1: Vetco KFDS - CSO Diverter.....	437
E.5.3: Mud-Gas Separator	446
E.5.4: Kelly Cocks, Safety Valves and High-pressure Piping	454
Section E.6: Motion Compensation System.....	458
E.6.1: Riser Tensioners	459
E.6.2: High-pressure Air System (Compressor, Piping/Valves, and APVs)	466
E.6.3: Drill String Compensator.....	473
E.6.3.1: Shaffer Chain Type Drill String Compensator.....	474
Section E.7: Well Control Equipment Testing.....	479
E.7.1: Wellbore Pressure Testing.....	480
E.7.2: Hydraulic Operating Chamber Testing, BOP Testing Pump	490

E.7.3: Rams.....	494
E.7.4: Annulars.....	496
E.7.5: Connectors (LMRP and Wellhead).....	499
E.7.6: Stack Valves and Lines.....	503
E.7.7: Function Testing.....	506
E.7.8: Accumulator Unit	510
E.7.9: Pods	514
E.7.10: Secondary Intervention, Emergency Acoustic Control	519
Section E.8: HPHT and Sour Gas Considerations.....	522
Table III - Wellbore Pressure Testing	
Table IV - Pressure Testing, Kill & Choke Valves from the Top	
Table V - Hydraulic Operating Chamber Pressure Testing	
References	

Note to Surveyors: Please note that the references listed with two letters and two numbers (i.e., MC31) are referencing the WEST Failure Database.

Table 1: Equipment List & 3 - 5 Year Survey Status

Equipment Type	Manufacturer and Model	Data	Documented Date of Last Repair	Documented Date of Last Major Survey/Replacement
BOP – Annular				
Upper Annular	Hydril GX Annuflex 10K	Packer part number: 3127398		New annuflex Feb-06. New element Dec-09. New operator kit Dec-09.
		Packer serial number: 0709-1408		
		Date of packer manufacture: Aug-09		
		Packer elastomer type: 1179		
		Date packer in service: Dec-09		
		Number of cycles: 6		
Lower Annular	N/A	Packer part number		N/A. No lower annular.
		Packer serial number		
		Date of packer manufacture		
		Packer elastomer type		
		Date packer in service		
		Number of cycles		
BOP – Rams				
Rams	Hydril Compact 15 K			
Size & Pressure Rating		18-3/4" 15K		
Number of Cavities		6		

Equipment Type	Manufacturer and Model	Data	Documented Date of Last Repair	Documented Date of Last Major Survey/Replacement
Pipe Ram #1 LPR	New ram body installed May-09 s/n M0970	New transfer seals & MPL bearings. Jul-04 MPL inspection change bearings and clutch plates in aft MPL. Apr-06 MPL inspection and new bearings. Mar-07 Forward bonnet new clutch plates and retainer plate. Mar-07		New bonnets installed. Apr-06 Lower wear plate. May-09 Top seal plate. May-09
Pipe Ram #2 MPR		New transfer seals & MPL bearings. Jul-04 MPL inspection change bearings. Apr-06		New bonnets installed. Mar-07 s/n C6405 - forward s/n C6406 - aft Lower wear plate. May-09 Top seal plate. May-09
Pipe Ram #3 UPR	New ram body installed May-09 s/n 135196	9-5/8" Casing rams MPL inspection and new bearings. Mar-07		Both bonnets new. Jul-08 Lower wear plate. Apr-06 Top seal plate. May-09
Casing Shears, 22" operators		pipe details 6-5/8" shear pressure		Both bonnets new. Jun-09 Lower wear plate. Dec-07
Lower Shear, 22" operators	New ram body installed May-09 s/n 134772	New transfer seals & MPL bearings. Jul-04 MPL inspection change bearings and clutch plates in forward MPL. Apr-06		New bonnets installed. Mar-07 s/n C6394 - aft s/n C6395 - forward Top seal plate. May-09 Lower wear plate. Mar-07 New ram blocks installed. Mar-07
Upper Shear Type 6 bolt blade 19" operators		New transfer seals & MPL bearings. Jul-04 MPL inspection change bearings and clutch plates in forward MPL. Apr-06 MPL inspection and new bearings. Mar-07		New bonnets installed. Oct-08 Top seal plate. May-09 Lower wear plate. Dec-07

Equipment Type	Manufacturer and Model	Data	Documented Date of Last Repair	Documented Date of Last Major Survey/Replacement
Lock Type(s)	MPL			
Controls				
Type - MUX	Cameron MUX Mark II			
Stack - Hard Piped or Hose		Hard pipe with jumper hose		
Secondary Intervention Systems currently Installed	deadman/autoshear/AMF functions	ROV: Yes Acoustic: No		
		EH Backup: No AMF: Yes		
		Autoshear: No Deadman: Yes		
ROV Operable Functions Currently installed	1) Riser Connector Gasket Release 2) Yellow Pod & Blue Pod Stack Stingers De-energize 3) Riser Connector Unlock 4) Choke & Kill Stabs Retract 5) PT / TT Electrical Stab Retract 6) Yellow Pod & Blue Pod Stack Stingers Retract 7) Ridged Conduit Flush Isolation Valve 8) Up. & Low. shear rams close 9) Casing shear rams close 10) Stack conn. unlatch 11) Stack conn. gasket release 12) Methanol injection 13) SS Acc. dump 14) Lower shear ram quick dump 15) Casing shear ram quick dump 16) Up. shear ram quick dump	ROV Pump capabilities Max GPM: 3 GPM Fluid: _____ seawater Reservoir Capacity: 5,500 psi		
		Max Pump PSI: 5,500 psi		

Equipment Type	Manufacturer and Model	Data	Documented Date of Last Repair	Documented Date of Last Major Survey/Replacement
Connectors				
LMRP Connector	Vetco HAR 10K	dog gap if applicable unlock pressure & Date		New. Jul-08
Mandrel				Installed new. May-09
Wellhead Connector	Cameron HC Collet15K s/n 96-1237237-10	dog gap if applicable unlock pressure & Date		New connector. Nov-08 New connector installed. DM May-10
Choke & Kill Retractable Stabs	Hydril 15K	Plating and hardfacing is coming off.		Choke line stabs replaced with new male/female stabs Jul-08. S/N C6407 Kill side female stab rebuilt Jul-08. Male stab replaced with new.
Mud System				
Choke Manifold				
Valves	WOM	Valves #10 and #6 rebuilt Apr-06		Valves rebuilt. Jan-03
Manual Choke	WOM	2" - 15K		
Hydraulic Choke	Shaffer	3" - 15K		A. Choke rebuilt. Jan-06 B. Choke rebuilt. Oct-06
Diverter	Vetco KFDS Type CSO			New piston, open cylinder head, operator seals and packer installed. Mar-07
Diverter System Valves				
Valves				
Lower Inner Kill Valve	WOM 3-1/16" 15K	S/N 9010		New complete valve installed. Mar-07 Actuator S/N A-9010A-1

Equipment Type	Manufacturer and Model	Data	Documented Date of Last Repair	Documented Date of Last Major Survey/Replacement
Lower Outer Kill Valve	WOM 3-1/16" 15K	S/N 9010		New complete valve installed. Mar-07 Actuator S/N A-9010A-2
Upper Inner Kill Valve	WOM 3-1/16" 15K			Valves rebuilt used gate, new seats and seals, used same retainers, stem. Apr-06
Upper Outer Kill Valve	WOM 3-1/16" 15K			Valves rebuilt new gate seats and seals, used same retainers, stem. Apr-06
Lower Inner Choke Valve	WOM 3-1/16" 15K			New double valve block fitted Dec-09 SN-A-4714-V1; date 09-2009
Lower Outer Choke Valve	WOM 3-1/16" 15K			New double valve block fitted Dec-09 SN-A-4714-V1; date 09-2009
Upper Inner Choke Valve	WOM 3-1/16" 15K			Valves rebuilt new gate seats and seals, used same retainers, stem. Apr-06 - New actuator. Mar-07
Upper Outer Choke Valve	WOM 3-1/16" 15K			Valves rebuilt new gate seats and seals, used same retainers, stem. Apr-06 - New actuator. Mar-07
Inner Annular Bleed Valve	WOM 3-1/16" 15K			New valve. Feb-06 Actuator. Jul-08

Equipment Type	Manufacturer and Model	Data	Documented Date of Last Repair	Documented Date of Last Major Survey/Replacement
Outer Annular Bleed Valve	WOM 3-1/16" 15K	S/N A4717-V1		New valve. Feb-06 Actuator. Jul-08
Choke Isolation Valve	WOM 3-1/16" 15K	S/N A4969-1		Valves rebuilt new gate seats and seals, used same retainers, stem. Apr-06
Kill Isolation Valve	WOM 3-1/16" 15K	S/N A-70011-V1		New valve block fitted Dec-09 date 07-2009
Riser Boost Valve	WOM 3-1/16" 15K	S/N 5242		Valves rebuilt new gate seats and seals, used same retainers, stem. Apr-06
Riser System				
Riser	Veteo HM ² -F 21"	Class F		May-03
Size & Length		75' x .812" Wall		
Load Rating		2,500,000 lbs.		
Number of Aux. Lines		4		
Upper Flex Joint	Oil States			
Telescopic Joint, Stroke	Veteo-PN H12261-18935	21" x 84.91' Stroke		Jun-09
Riser Tensioners, No., Size	Hydralift N-Line	6 ea x 400 Ton		
Flex Joint (LMRP)	Hydril Annuflex (Oil States)			New. Jun-03
Motion Compensator				
Motion Compensator	Varco Shaffer CMC	CM-25-1000-DA		

Table II – Flexible Hoses

Check high pressure auxiliary line hoses for current inspection certificates, including full internal and external inspections, as per original equipment manufacturer's specifications. Record this and serial number, dates of manufacture and last survey in the table below. The certificates should be on the rig or readily available. Reference API RP 53 Sections 18.10.3 and 18.13.2, and MMS Title 30 Chapter II, Section 250.446, Paragraph (a). Manufacturer recommended testing intervals can be found in WEST ITP #56.

HP Hose	Manufacturer	Length (ft)	WP	Install Date	S/N	Cert. Date	Date of Last Internal Insp.	Date of Last Rig Test	Manuf. Date
BOP Choke - Hull*	Coflexip	91 ft	15,000 psi	Aug-04	45A285-201	15-Nov-03		May-08	Nov-03
BOP Choke Line - Gooseneck*	Coflexip	91 ft	15,000 psi	Aug-06	46A071-201	10-Dec-04		May-08	Dec-04
BOP Kill Line - Hull	Coflexip	91.8 ft	15,000 psi	Jun-03	43A137-201A	14-Dec-00		May-08	Dec-00
BOP Kill Line - Gooseneck	Coflexip	90.97 ft	15,000 psi	Aug-04	45A370-201A	12-Feb-04		May-08	Jan-04
Boost Line - Hull	Coflexip	90.61 ft	10,000 psi	Aug-04	45A300-201	6-Nov-03		May-08	Nov-03
Boost Line - Gooseneck**	Dunlop	90.76 ft	10,500 psi	Feb-06	46A579-201	27-Oct-05		May-08	Oct-05
Conduit Line - Hull	Copper States	91.1 ft	5,000 psi	Aug-04	14462	5-Dec-00		May-08	Nov-00
Conduit Line - Gooseneck**	Copper States	90.92 ft	5,000 psi	Jun-05	19052	30-Sep-04		May-08	Sep-04
<i>*The actual installed position of these hoses may be reversed.</i>									
<i>**This hose was removed from the aft rotary to replace the damaged boost hose until a 10K replacement can be obtained and installed.</i>									
BOP Kill									
BOP Conduit									
Moonpool C, K or B									
Moonpool Conduit									

ID	Assessment Point	Reference	Previous Status	Current Status	Inspection Method	Comments
1	Section E.1: Operational Management	*WEST ITP #91, Operational Management				
2	E.1.1: Entry/Exit Meetings					
3	An entry meeting shall be held with the customer and contractor personnel on the rig prior to the start of the assessment. The meeting should include the following:					
4	1) List the personnel in the meeting and provide email addresses (contact information) for the OIM and Rig Manager, Subsea Engineer and Rig Maintenance Supervisor:		C Dec-09	C	I	George Walker (BP Companyman) discover@bp.com
5	2) Discuss the distribution of daily reports and other assessment information. Determine the schedule for delivery of daily reports and the list of recipients. After verification of distribution and authorization, ensure that the WEST client contact receives copies of the dailies.		C Dec-09	C	I	
6	3) This ATP, the workscope for the assessment and safety issues shall be discussed.		C Dec-09	C	I	
7	4) Discuss the objectives of the well and identify any special issues that should be addressed (e.g., temperature, pressure, etc.)		C Dec-09	C	I	
8	5) Discuss closing out of recommendations from previous assessments, if any.		O Dec-09	C	I	
9	6) Discuss the Priority Matrix for WEST recommendations, including definitions for the Priorities, Consequences and Probabilities.	*WEST Recommendation Summary and Disposition	O Dec-09	O		
10	7) Discuss anomalies that concern DTE equipment on this rig and determine the status of the anomaly.		C Dec-09	O		
11	8) Discuss reporting of equipment design problems/failures using Product Performance Reports, PPRs.	*WEST ITP #84, Product Performance Reports	O Dec-09	C	I	

ID	Assessment Point	Reference	Previous Status	Current Status	Inspection Method	Comments
12	At completion of the assessment, an exit meeting shall be held with customer and contractor personnel on the rig. The meeting should include the following:		O Dec-09	O		No meeting was held due to departing the rig and transferring to the DD II.
13	1) Personnel in the meeting:		O Dec-09	O		
14	2) Discuss and provide a preliminary copy of the completed ATP and/or a list of outstanding workscope from the assessment.		C Dec-09	O		
15	3) Discuss and provide an updated, preliminary copy of the Recommendation Summary and Disposition.		C Dec-09	O		
16	4) Ensure that the WEST client contact receives preliminary copies of the ATP and Recommendation Summary and Disposition.		O Dec-09	C	D	
17	E.1.1.1: Safety					
18	The surveyor shall participate in contractor's JSA (Job Safety Analysis) with the appropriate personnel prior to commencement of every new phase of inspection or testing.	*IADC Safety Alert 03-06	C Dec-09	C	I	
19	Verify that JSAs include procedures to vent all pressure from any piece of equipment that is to be worked on before work commences.		C Dec-09	C	D	
20	E.1.1.2: Documentation					
21	Review the anomalies applicable to the equipment. Update the closure status of each anomaly in the spreadsheet provided.		O Dec-09	O		
22	E.1.2: Written Requirements					
23	WEST ITPs (Inspection and Test Procedures) are referred to as required, but are not included as part of this procedure. The latest revision ITP should always be used and should be secondary to regulations.					

ID	Assessment Point	Reference	Previous Status	Current Status	Inspection Method	Comments
24	Regulatory requirements are inserted as appropriate. Sometimes specific regulatory requirements are different than API requirements. The intent is to comply with the applicable regulation, thus API requirements are of secondary importance if regulations have a specific requirement.					
25	E.1.3: Planned Preventive Maintenance	*WEST ITP #3, Preventive Maintenance Plan Review				
26	Verify drawings showing ram space-cut and bore of the BOP stack.	*API RP 53, 3rd Edition, Section 18.13.1	C Dec-09	O		
27	Verify a drawing of the choke manifold showing the pressure rating of the components is on the rig and maintained up to date.		O Dec-09	O		
28	The planned maintenance system on each rig should identify the equipment, specify tasks and specify time intervals between tasks. Records of the maintenance or repairs performed should be filed on the rig or be readily available. Review and comment.	*API RP 53, 3rd Edition, Section 18.12.1; WEST ITP #3, Preventive Maintenance Plan Review *MMS CFR Title 30, Chapter II, Section 250.446, Paragraph (a)	C Dec-09	C	D	
29	Verify that a procedure is in place to inspect all threaded fasteners in the load path of the BOP/Connectors/Riser system. The system should also verify that all fasteners are 35 Rockwell "C" (Re) maximum. Fasteners in the riser string should be inspected annually; throughbore and side outlet fasteners should be inspected during the 3-5 year survey. <i>{Apr-06 The riser bolts are checked 20% a year and tracked on a spread sheet. This rig move 85 were NDT checked, and will be changed out. The BOP bolts are visually checked every rig move. 2 were replaced with new this move.}</i>	*MI05; WEST ITP #175, Hydrogen Embrittlement	C Dec-09	O		

ID	Assessment Point	Reference	Previous Status	Current Status	Inspection Method	Comments
30	Review the Major Survey status and update Table I. Add any equipment that has been added or changed.	*API RP 53, 3rd Edition, Section 18.12.1 *MMS CFR Title 30, Chapter II, Section 250.446, Paragraph (a)	C Dec-09	C	D	Added new Cameron HC Collet Connector to Table I.
31	Review a Major Survey status and update Table I. Note that per API RP 53, a Major Survey must be conducted every 3-5 years. To satisfy the requirements of a Major Survey, the equipment should be completely disassembled and inspected in accordance with manufacturer requirements, including a dimensional inspection of critical areas and surface finishes and replacement of elastomeric components. The documentation is to be confirmed prior to any work or testing on the equipment.	*ITP #10 Major Survey, and CAR 09-0302-001.	C Dec-09	C	D	Made recommendation about moonpool Collexip type hoses.
32	Verify that each piece of pressure control equipment has an existing data package available for review. The data package should contain NACE, manufacturing, and API certifications.	*ITP #155, Data book Review.	C Dec-09	C	D	
33	E.1.4: Operations & Maintenance Manuals					
34	Manufacturers' installation, operation and maintenance manuals should be available on the rig for all the BOP equipment installed on the rig.	*MMS CFR Title 30, Chapter II, Section 250.446, Paragraph (a) *API RP 53, 3rd Edition, Section 18.11.1; WEST ITP #103, O&M Manual Requirements	C Dec-09	C	D	
35	Manufacturers' EBs and Product Alerts: A system must be in place that assures that the OEMs' (original equipment manufacturers') product alerts and engineering bulletins are available and properly considered for implementation and closed as appropriately.	*MMS CFR Title 30, Chapter II, Section 250.446, Paragraph (a) *API RP 53, 3rd Edition, Section 18.12.2	C Dec-09	C	D	

ID	Assessment Point	Reference	Previous Status	Current Status	Inspection Method	Comments
36	E.1.5: Replacement Parts					
37	After the stack has been latched to the wellhead and successfully tested, perform a review of critical preventive maintenance records, spare parts and operational procedures. <i>{Item not checked since before Apr-06.}</i>	*WEST ITP #3, Preventive Maintenance Plan Review	O Dec-09	O		
38	Verify suppliers of spare parts are original equipment manufacturers, OEM. Comment on stocking levels and storage techniques.	*API RP 53, 3rd Edition, Section 18.11.3 *MMS CFR Title 30, Chapter II, Section 250.446, Paragraph (a)	C Dec-09	C	V	
39	Verify that a physical inventory of contractually required critical rubber goods is conducted as early as possible in the survey.	*Reference CAR 07-10	C Dec-09	C	V	
40	E.1.6: Quality Management					
41	Discuss predictive testing detailed in WEST ITP #88 with the operator and the contractor on the rig. At a minimum, perform the benchmark testing to obtain the minimum pressure to operate the rams open and closed and operate the locks, if so equipped.	*WEST ITP #88, Ram Locking Systems - Predictive Testing, Design Verification and Maintenance	C Dec-09	C	I	
42	Calibration of gauges and chart recorders should be current and each gauge and recorder tagged. Chart recorders should have a maximum four hour rotation. All pressure gauges should be calibrated to an accuracy of 1% of full scale at least every three years. This applies to gauges on the BOP control system, choke and kill manifold and motion compensation equipment. <i>{Mar-07 Chart recorder calibration was due on 8-Mar-07.}</i>	*MMS CFR Title 30, Chapter II, Section 250.442, Paragraph (c) *API RP 53, 3rd Edition, Sections 13.3.8 and 13.9.3.g. API Spec 16A, 3rd Edition, Section 8.2.2	C Dec-09	/	V	A visual inspection was performed on the BOP high pressure test unit. It was noted the pressure gauges did not have a calibration date sticker affixed.

ID	Assessment Point	Reference	Previous Status	Current Status	Inspection Method	Comments
43	Test pressure measurements shall be made at no less than 25% or more than 75% of the full pressure span of the gauge.	*API RP 53, 3rd Edition, Section 18.3.6; API Spec 16A, 3rd Edition, Section 8.2.2; API Spec 16C, 1st Edition, Section 6.1.2.2	C Dec-09	C	V	
44	Pressure gauges shall have a minimum face diameter of 4.0 inches.	*API Spec 16A, 3rd Edition, Section 8.2.2	C Dec-09	C	V	
45	Verify that wellbore wetted rubber goods are in as new condition. Verify manufacturer's data is recorded on all rubber goods and the documentation stored in the proper location. <i>{Mar-07 All replaced with new except 9 5/8" casing rams.}</i>	*API RP 53, 3rd Edition, Section 18.12.1	C Dec-09	C	V	All ram rubber goods replaced except the 9-5/8" casing rams. Visually inspected the annular element.
46	Verify that any "equipment malfunctions or failures" are being reported in writing to the equipment manufacturer as stated in API Spec 16A, 3rd Edition. Review reporting system.	*API RP 53, 3rd Edition, Sections 18.3.7 and 18.13.3; API Spec 16A, 3rd Edition, Annex F; WEST ITP #57, Equipment Repairs - Welding	C Dec-09	C	D	
47	Verify that a Management of Change system is in place to ensure that changes to equipment, systems and software are analyzed for potential problems and their effects on associated equipment and systems. The system should also ensure that all information on the rig (drawings, control system schematics, data books, maintenance procedures, etc.) is updated accordingly.	*API RP 75, 3rd Edition, Section 4.1; API RP 53, 3rd Edition, Section 18.13.1	C Dec-09	C	I	
48	Verify that weld repairs on drill through equipment are not performed on the rig.	*MI06; WEST ITP #57, Equipment Repairs ? Welding; API RP 53, 3rd Edition, Section 18.11.7	C Dec-09	C	I	

ID	Assessment Point	Reference	Previous Status	Current Status	Inspection Method	Comments
49	Section E.2: BOP Stack Inspection					
50	All drill through equipment bores should be drift tested to ensure full bore tools will pass without obstruction. Drift testing should be completed after all wellbore testing is complete to verify the rams and annulars have fully opened. Per API Spec 16A, Section 8.5.8.4, the annular must return to full bore within 30 minutes after piston has been opened. <i>{Dec-09 Will be drifted after final annular pressure test.}</i>	*API Spec 16A, Section 8.5.8.4	/ Dec-09	/	T	The BOP was not drift tested.
51	E.2.1: End Connections and Side Outlets					
52	Targets on the subsea valves, choke manifold and high-pressure piping will be disassembled for visual inspection. Lead targets should have a positive retention mode, a counterbore, and be drilled to reduce the tendency of wellbore pressure forcing the lead out of its retention mode. Quiet zone targets are acceptable. Record findings. <i>{Apr-06 Targets pulled - no lead inserts.}</i>	*WEST ITP #75, Target Flanges	O Dec-09	O		
53	Hydraulic torquing equipment and a thread lubricant with a known coefficient of friction (suggested to contain molybdenum disulfide, e.g. NSW-503) shall be supplied.	*API RP 53, 3rd Edition, Section 18.11.4 *MMS CFR Title 30, Chapter II, Section 250.446, Paragraph (a)	C Dec-09	C	V	Moly 503 used.
54	Bolt preloading procedures for drill through connections and side outlets shall be reviewed. Note: Close to 90% of the effects of embedment relaxation Noted in API RP 53 can be counteracted by re-torquing any newly made up connection after a full working pressure test.	*API RP 53, 3rd Edition, Section 18.11.2 *MMS CFR Title 30, Chapter II, Section 250.446, Paragraph (a)	C Dec-09	C	V	
55	Connections broken in the last six months will be re-tightened to prove preload accuracy. <i>{Dec-09 Will be re-tightened after final pressure test. Lower choke and kill isolation valve.}</i>	*MMS CFR Title 30, Chapter II, Section 250.446, Paragraph (a) *API RP 53, 3rd Edition, Section 18.11.2	/ Dec-09	C		

ID	Assessment Point	Reference	Previous Status	Current Status	Inspection Method	Comments
56	Hardened washers are recommended for use under the nuts on the clamp connections. <i>{Apr-06 Flange connections on all.}</i>	*API RP 53, 3rd Edition, Sections 17.11.2 and 18.11.2 *MMS CFR Title 30, Chapter II, Section 250.446, Paragraph (a)	N/A Dec-09	N/A		
57	When assembling AX, BX, and CX flanges and hubs, they will achieve face-to-face contact with the specified torque or the connection will be disassembled to determine the cause.	*WEST ITP #4, Connection Inspection and Installation	C Dec-09	C	V	
58	Ensure all bonnet bolts and flanges are torqued in accordance with good oilfield practice.	*WEST ITP #187, Fastener Assembly and Torque	C Dec-09	C	V	
59	A193 Grade B-7 studs and A194 Grade 2H nuts shall be used on all API flanged end connections, including studded.	*API Spec 6A, 19th Edition, Section 10.3 and Table 49 - PSL 1; API Spec 16A, 3rd Edition, Section 5.3.3	C Dec-09	C	V	
60	If the rig has a history of side outlet washouts, or if major equipment such as BOPs or frame attachment components have been replaced, measure movement between the stack frame and choke and kill lines. If movement over .070 inch is found, it shall be reduced to assure excessive external bending loads are not transmitted to the choke and kill outlets. Record final movement. <i>{Apr-06 No history.}</i>	*WEST ITP #50, Measuring BOP Stack Framework Movement; WEST ITP #4, Connection Inspection and Installation	C Dec-09	C	I, D	
61	Ensure all tubular stack frame members have relief holes to prevent collapse caused by hydrostatic pressure when subsea. <i>{Apr-06 Stack 1-beam.}</i>	*MF02	N/A	N/A		
62	Confirm hardness of studs/nuts installed has been verified HRC 35 or less.		C Dec-09	C	D	

ID	Assessment Point	Reference	Previous Status	Current Status	Inspection Method	Comments
63	Confirm all studs are properly torqued with approved lubricant during most recent 5 year survey.		C Dec-09	C	V	
64	Confirm all ring gasket seal preps were inspected during most recent 5 year survey.		C Dec-09	O		
65	Confirm MPI or dye penetrant testing of flanges was completed during most recent 5 year survey.		C Dec-09	O		
66	Confirm a stack deflection test was performed during most recent 5 year survey.		O Dec-09	O		
67	E.2.2: Ram BOPs	*RAM BOP HISTORY				
68	Verify that the hang-off point is located so that, if it is necessary to shear the drill pipe, there is adequate room between the hang-off ram and the shear ram to leave an adequate fishing neck and not shear in the upset of the pipe. Drill pipe on the rig to be used in the program should be checked for actual tool joint length and compared to the available space. If hanging-off on VBRs, verify hang-off capacity for size pipe in use. <i>{Apr-06 Stack Configuration: upper S/R LS/R: Casing S/R UPR (VBR) MPR (VBR) LPR (9-5/8 fixed).}</i>	*MMS CFR Title 30, Chapter II, Section 250.446, Paragraph (a) *MR44	O Dec-09	O		The stack configuration is: Annular Upper Blind Shear Rams Lower Blind Shear Rams Casing Shear Rams Upper HVR 4-1/2"x7" Middle HVR 4-1/2"x7" Lower 9-5/8" Casing Rams
69	For the drill pipe in use, verify that the rams used for hangoff can accommodate the external upset diameter below the tool joint. In a hangoff situation, there could be interference with the rams causing difficulty in sealing. If interference is suspected, the BOP manufacturer should be consulted to determine sealing capabilities or modifications required. <i>{Item not checked since before Aug-05.}</i>	*MR41	O Dec-09	O		

ID	Assessment Point	Reference	Previous Status	Current Status	Inspection Method	Comments
70	Verify that the blind/shear rams installed in the BOP stack (both surface and subsea stacks) are capable of shearing the drill pipe in the hole under maximum anticipated surface pressures. Update Table I with pipe details and shear pressure required. <i>{Apr-06 Upgrading casing shear rams to a 4000 psi system.}</i>	*MMS CFR Title 30, Chapter II, Section 250.416, paragraph (c)	O Dec-09	O		
71	Review any shear test results and procedure used for shearing drill pipe. Verify hydrostatic head, wellbore pressure beneath the annular and a factor of safety are included in the shear pressure analysis. <i>{Apr-06 The rig just upgraded casing shear rams to a 4K operating system. The upper and lower blind shear rams have an HP button which shears at 3000 psi.}</i>	*API RP 53, 3rd Edition, Section 18.5.6; API Spec 16A, 3rd Edition, Annex C.2.3; WEST ITP #58, Shear Testing; WEST ITP #68, Effects of Wellbore Pressure on Closing Rams; SR53	O Dec-09	O		
72	Record and compare the weight, grade and impact strength of the drill pipe in use. <i>{Item not checked since before Aug-05.}</i>	*API RP 53, 3rd Edition, Sections 17.5.6 and 18.5.6; API Spec 16A, 3rd Edition, Annex C.2.3; WEST ITP #58, Shear Testing; WEST ITP #68, Effects of Wellbore Pressure on Closing Rams; SR53	O Dec-09	O		

ID	Assessment Point	Reference	Previous Status	Current Status	Inspection Method	Comments
73	Check general condition of ram cavities. Visually inspect each cavity upper sealing area for or any scratches. Note: A poor surface finish at the top of the cavity reduces its effective life. <i>{Apr-05 Upper and middle pipe rams wear plates replaced, wear plate on order for lower pipe.}</i>	*API RP 53, 3rd Edition, Section 18.10.1; WEST ITP #16, Ram Preventers - General; IADC Deepwater Well Control Guidelines, Section 3.7.2.1 *MMS CFR Title 30, Chapter II, Section 250.446, Paragraph (a)	C Dec-09	C	V	
74	Verify procedures are in place to check and record ram cavity dimensions at least annually. Compare ram cavity wear measurements to OEM's recommended maximum tolerance.	*WEST ITP #16, Ram Preventers - General; IADC Deepwater Well Control Guidelines, Section 3.7.2.1	C Dec-09	C	D	
75	The rig should have available a calibrated ID + OD Micrometer for measuring ram blocks and ram cavities.	*API RP 53, 3rd Edition, Section 18.10.3 *MMS CFR Title 30, Chapter II, Section 250.446, Paragraph (a)	C Dec-09	C	V	
76	Ram shaft and packing plus bonnet sealing surfaces and bolts shall be inspected.	*API RP 53, 3rd Edition, Section 18.10.1 *MMS CFR Title 30, Chapter II, Section 250.446, Paragraph (a)	C Dec-09	C	V	
77	MPI Ram Block for cracks in the area in contact with the ram shaft.	*MMS CFR Title 30, Chapter II, Section 250.446, Paragraph (a) *API RP 53, 3rd Edition, Section 18.10.3; WEST ITP #16, Ram Preventers - General	C Dec-09	O		

ID	Assessment Point	Reference	Previous Status	Current Status	Inspection Method	Comments
78	MPI ram shaft to ram connection button or foot.	*API RP 53, 3rd Edition, Section 18.10.3; WEST ITP #16, Ram Preventers - General *MMS CFR Title 30, Chapter II, Section 250.446, Paragraph (a)	C Dec-09	O		
74	Confirm all bonnet seal carriers installed are rated for high external differential hydrostatic pressure.		C Dec-09	C	D	
75	Confirm upgraded mud seal and seal retainer and relief valve installed on all rams are rated for high external differential hydrostatic pressure.		C Dec-09	C	D	
76	Remove all shear ram blade bolts and MPI bolts, blades and blocks before Kaskida well test		C Dec-09	O		
77	Verify blade bolt torque/lubricant is correct on all shear rams.		C Dec-09	C	T	
78	Confirm acceptable upper cavity seal surface condition on all ram cavities before Kaskida well test.		C Dec-09	C	V	
79	Verify all cavity, ram blocks and seal seat gap measurements are within OEM specs.		C Dec-09	O		
80	Verify all operator tests have been conducted within last six months.		C Dec-09	/	D, I	
81	Verify lock operability and predictive tests are performed between wells on all ram preventers.		C Dec-09	C	T	
82	Verify wellbore pressure tests are conducted on the surface with locks only applied (no closing pressure). <i>(Dec-09 Not tested on locks; discussed with BP co. rep. prior to stump test.)</i>		/ Dec-09	C		
83	Review maintenance history on bearings.		O Dec-09	O		
84	Verify annual MPI of bonnet bolts, as well as thread measurements.		C Dec-09	O		

ID	Assessment Point	Reference	Previous Status	Current Status	Inspection Method	Comments
90	E.2.2.1: Hydril BOPs					
91	Check clearance between upper seat seal and BOP body. On 10K and 15K BOPs, an even clearance of .011" is desirable. This clearance should at no time be greater than .019". <i>{Apr-06 All were within the acceptable level, between .005" to .011"}</i>	*Hydril Operator's Manual	C Dec-09	O		
92	Compare ram cavity measurements to Hydril's recommended maximum. The gap between the ram block and upper seal seat should not exceed 0.063" for shear rams, 0.087" for fixed bore pipe rams and 0.078" for variable rams.		C Dec-09	O		
93	Verify if O-ring is installed or if filler ring is in place. It is not necessary to remove the upper seal seats to specifically remove the O-rings.	*WEST ITP #19, Hydril Ram Preventer	C Dec-09	O		
94	Inspect the surface of the piston rod for pits, dings, or gouges. Marks less than .005" may be polished out.	*WEST ITP #19, Hydril Ram Preventer	C Dec-09	C	V	
95	Check the ram guide pins or rods in the 18-34" 15K BOP for the proper torque of 75 ft-lbs at least annually and/or every time the bonnets are open for changing packers. A thread locking compound such as Loctite may be used.	*WEST ITP #19, Hydril Ram Preventer; Hydril EB 98001	C Dec-09	C	T	
96	Inspect shear ram Lateral T seal. Record part number and revision of seal in use. Ensure the correct Lateral T seal compatible with the temperature and the drilling fluids in use is installed. <i>{Mar-07 Replaced with new.}</i>	*WEST ITP #19, Hydril Ram Preventer; Hydril EB 96005	C Dec-09	C	V, D	See Daily Report #6.
97	Check the Hydril Variable Rams for proper retention of extrusion plates. The loss of lower extrusion plates has been noted.	*WEST ITP #19, Hydril Ram Preventer	C Dec-09	C	V	

ID	Assessment Point	Reference	Previous Status	Current Status	Inspection Method	Comments
98	Determine minimum operating pressure required to close and open rams. This should be in the 100-200 psi range. Rams should operate smoothly. Rams should be operated open and close, as functioning affects opposite bearings. If a pressure greater than 200 psi is required to open or close the ram, the locks should be disassembled for inspection. Record findings.	*WEST ITP #19, Hydril Ram Preventer	C Dec-09	C	T	
99	Verify and record part number and revision level of MPL bearings and nuts installed. Hydril's recent recommendation is to replace the bearings every 12-18 months. Record dates last changed. <i>{Apr-06 Bearings changed.}</i>	*Hydril EB 99013A	O Dec-09	O		
100	Ensure procedures are in place so that Hydril BOPs equipped with 22 inch MPL operators are not operated without the ram blocks installed.	*HR35; Hydril PNI 01-001	C Dec-09	C	I	
101	The original 18-3/4" 15K bonnet seal carrier external pressure limit is 660 psi. Verify that Hydril PNI 03-003 is available on the rig. An upgraded bonnet seal carrier, resistant to collapse due to hydrostatic differential down to 10,000 ft water depth, is available. If the upgrade is not being considered, verify applicable procedures are in place that address the external pressure limitations of the original design. <i>{Apr-06 Upgrade has started. Casing shear ram and lower pipe ram have upgraded seal carriers.}</i>	*IIR48; Hydril PNI 03-003	C Dec-09	C	V, D	
102	Verify the lower wear plate has been upgraded in accordance with Hydril Engineering Bulletin 98002.	*Hydril EB 98002	O Dec-09	O		
103	Verify that the upper shear ram block used with 19" and 22" operators are the six blade bolt type. There is no difference in the lower rams. The 4 blade bolt type upper ram is still acceptable for 15.5" and smaller operators.	*Hydril EB 04-001, Rev A1	C Dec-09	C	V	

ID	Assessment Point	Reference	Previous Status	Current Status	Inspection Method	Comments
104	If the shear rams are equipped with alignment pins, measure the diameter of the pins on the upper blade carrier and the holes on the lower carrier. Clearance between the guide pin and the hole should not exceed 0.012" for 18-3/4" 10K rams and 0.046" for 18-3/4" 15K rams. Consult reference material for other size BOPs.	*Hydril Ram BOP Inspection Manual 9407, Table 4-1	O Dec-09	O		
105	Perform the MPL clutch test in accordance with Hydril EB 05-009.	*Hydril EB 05-009	O Dec-09	C	T	
106	E.2.3: Annular BOPs	*ANNULARHISTORY				
107	Verify that the annulars were disassembled for complete inspection of possible trapped swarf and/or milling damage after the last milling operation. If the annulars were not disassembled for inspection, they should be now unless client approval has been given for accepting them as is. Client approval: _____ <i>{Apr-06 Annulars changed out in Feb-06.}</i>	*WEST ITP #65, Swarf and BOPs	C Dec-09	C	V	The annular element was visually inspected using the WESTscope camera. The video was given to the subsea engineer. DM-May-10
108	Verify that any surge bottles installed in the close side hydraulic line are as close to the preventer as possible and are precharged to manufacturer's specifications or 500 psi plus hydrostatic pressure of proposed water depth.	*MMS CFR Title 30, Chapter II, Section 250.446, Paragraph (a) *API RP 53, 3rd Edition, Sections 13.3.7, 18.5.12 and 18.3.8; WEST ITP #12, Annular Preventer - General	C Dec-09	C	V	
109	Record all available information on the annular packers/elements in Table I. Verify packer is within shelf life of manufacturer.	*API RP 53, 3rd Edition, Sections 18.5.10 and 18.5.10.1 *Australian Petroleum Submerged Lands Acts Part V, 505 (1)	C Dec-09	C	D	

ID	Assessment Point	Reference	Previous Status	Current Status	Inspection Method	Comments
110	E.2.3.1: Hydril GX Annulars	*WEST ITP #4, Hydril Type GX Annular				
111	Verify the appropriate 18-3/4" 10K annular packer is installed for stripping the drill pipe in use. In some cases, old stock packers have not been modified to allow stripping 6-5/8" drill pipe. The new part number is 3127398 Rev. B1.	*Hydril EB #01-006, Rev A1	C Dec-09	C	D	
112	Verify that high interflow shuttle valves are used on the open and closed ports.	*HA08	C Dec-09	C	V	
113	E.2.4: Connectors	*WEST ITP #31, Wellhead and Riser Connectors - General				
114	Ensure resilient gaskets are not used during BOP stack stump tests (unless approved by operator). Resilient gaskets may mask defects in the groove.	*CONNECTOR HISTORY	C Dec-09	C	T	
115	Indicating flags easily visible to the subsea camera and/or the ROV will be on all connectors including the LMRP connector, and wellhead connector, and as appropriate, choke/kill connectors.	*WEST ITP #21, Wellhead and Riser Connectors - General	C Dec-09	C	V	
116	The secondary unlocking function on both the wellhead and LMRP connectors should be independent of the primary unlocking function.	*WEST ITP #21, Wellhead and Riser Connectors - General	C Dec-09	C	V	
117	If testing for backdriving has not been successfully accomplished, a pilot operated check valve (POCV) should be used on the lock side of the wellhead connector. An ROV operated bypass ball valve should be installed around the POCV and clearly marked. <i>{Item not checked since before Aug-05.}</i>	*WEST ITP #39, Backdriving - Hydraulic Connectors	O Dec-09	O		
118	Ensure that an upside-down J-tube has been installed in the test port of the test stump. This will act as a mud excluder to prevent the test hose becoming plugged and trapping test pressure in the stack. <i>{Aug-05 Rig has no LMRP test stump.}</i>		C Dec-09	N/A		WEST was informed that the rig will not install a J-tube. DM May-10

WEST ©

ID	Assessment Point	Reference	Previous Status	Current Status	Inspection Method	Comments
119	E.2.4.1: LMRP Connector					
120	Disconnect the LMRP to inspect the sealing components between the LMRP and the BOP. Change the choke and kill packing and connector gasket. <i>{Mar-07 Done prior to WEST's arrival.}</i>		O Dec-09	O		
121	E.2.4.1.1: Vetco HAR H-4 Connectors	*WEST ITP #24, Vetco - H-4 Connectors; Vetco OSP 335				
122	Pressure test gasket retainer extend/retract chambers: 1,500 psi/5 min. Visually inspect the gasket retainer pins for damage.		O Dec-09	O		
123	Visually inspect VX ring groove condition prior to using/pressure testing. Verify surface finish of the stainless steel ring groove to be 32 RMS or better.		O Dec-09	O		
124	Record the gap between the dog segments and the upper wear band on the Vetco connector in Table I. This should be performed at least yearly, sooner if problems are found during testing. The gap should be measured with the connector in the unlatched position after cleaning. If the recorded gap is incorrect, it may be cycled again and the gap rechecked in the latched position. As a last resort, it may be necessary to remove the dogs and compare the dog measurement to the cavity measurement to determine the actual gap. The allowable gap is .014" to .039". <i>{Item not checked since before Apr-06.}</i>	*WEST ITP #24, Vetco - H-4 Connectors	O Dec-09	O		
125	Older style HAR connectors require a transfer barrier (water over oil reservoir) for the secondary unlock chambers. The older style was built with the cylinders and heads on top. The latest HAR connector has the cylinders on the bottom, just like the standard E connector, and does not require the transfer barrier. If a XFR Barrier is installed, verify the oil level is adequate.		O Dec-09	O		

ID	Assessment Point	Reference	Previous Status	Current Status	Inspection Method	Comments
126	After all wellbore testing is complete, perform the predictive unlocking test. Record the date and pressure in Table I. The unlocking pressure should be checked against ABB Vetco allowables.	*Vetco OSP 335	O Dec-09	O		
127	Lubricate the connector off the stump by pumping through each of the two button head grease fittings until grease is evident between the dog segments. Completely cycle the connector lock and unlock 5 to 6 times to distribute the grease. Remove any excess grease when in the locked position. Acceptable lubricants are Alco Jet Lube #73 or equivalent Almagard 3752, Lubriplate 630AA and Lubriplate 930AA.	*Vetco OSP 335	O Dec-09	O		
128	Verify that all dogs properly retract by locking off the stump or mandrel and checking the dogs after unlocking. Failure to properly retract requires cleaning at a minimum and/or measuring of dog to window gap.		O Dec-09	C	V	
129	E.2.4.1.2: Vetco Test Stumps					
130	Visually inspect VX ring groove condition prior to using/pressure testing.		O Dec-09	O		
131	Verify the existing gasket prep will allow the use of the VT gasket. <i>{Mar-07 No VT prep.}</i>		O Dec-09	O		
132	For test stumps that are equipped with replaceable J-slot tool joint inserts, ensure the test joint or drill pipe is open and never plugged. The J-slots are not meant to retain the full wellbore pressure loads. Ensure that the bypass outlet is not plugged.		O Dec-09	O		
133	Verify spare parts for the test stumps include: 1 set static seals, tubing/fittings as needed and 1 each of any special component or sub-assembly that could cause downtime (J-slot parts).		O Dec-09	O		

ID	Assessment Point	Reference	Previous Status	Current Status	Inspection Method	Comments
134	E.2.4.2: Wellhead Connector					
135	If applicable, determine what steps are being taken to prevent hydrate difficulties during the drilling campaign. Potential remedies include: {Apr-06 Hydrate seal installed Mar-06.}		C Dec-09	C	V	The rig plans on installing a hydrate barrier before the stack is run. This has not been determined by BP.
136	a) Installation of an inverted cone to divert hydrates away from the connector. This shield would normally be installed on the OD of the 18-3/4" high-pressure housing.		N/A Dec-09	N/A		
137	b) A seal installed on the lower portion of the connector to prevent the entry of hydrates.		C Dec-09	N/A		
138	c) Glycol injection ports.		C Dec-09	C	V	
139	Will the existing gasket prep allow the use of the VT gasket?		O Dec-09	O		
140	Verify the orientation of the wellhead connector tubing hanger alignment slot per operator requirements, if applicable.		O Dec-09	O		
141	Determine if connector seal prep has AX-AT profile.		O Dec-09	O		
142	Visual inspection prior to BOP run. Stump test to maximum working pressure.		C Dec-09	C	T	Stump tested to MWP.
143	Conduct stroke limit check with connector before BOP is run.		C Dec-09	C	V	On stump - Latched 3/8" stickup, Unlatched 6-3/4" stickup.
144	Conduct backdriving test with dial indicator before BOP is run.		O Dec-09	O		
145	Visually determine if OEM Everslik is present on actuator ring.		O Dec-09	C	V	New connector DM May-10
146	Verify a minimum of 500 psi latch pressure is maintained on wellhead connector. Determine if pilot operated check valve with ROV operated bypass or cut hose is in place.		C Dec-09	C	T	No POCV installed.

ID	Assessment Point	Reference	Previous Status	Current Status	Inspection Method	Comments
147	E.2.4.2.1: Cameron DWHC Connectors	*WEST ITP #23, Cameron Model HC Connectors; Cameron EB #687M, Cameron O&M Manual				
148	Inspect the actuator ring locking surface for the correct coating. Everslick is the only approved coating and is orange colored. It should only be applied to the 4 degree taper of the actuator ring. If the coating is present, grease only the hubs and other parts of connector. Mystik Blue or Mystik IT6 grease, from Cato Oil and Grease Company, are preferred. Other grease with a confirmed coefficient of friction of .10 to .15 may be used. If more than 80% of the coating is missing from the actuator ring locking surfaces, grease should also be applied to these surfaces. Spray exposed studs with oil. <i>{Mar-07 Checked the Everslick coating on the actuator ring. It is in good condition, but is dark green in color, as stated in WEST ITP #161, Rev. 1.</i>	*Cameron EB #842M, Rev B1; CO23	O Dec-09	N/A		The wellhead connector has been changed out and a new Cameron HC Collet Connector has been installed. DM May-10
149	Pressure test gasket retainer release chambers: 1,500 psi/5 min. Visually inspect the gasket retainer pins for damage. Verify pins stroke out completely when retracting pressure is released. <i>{Dec-09 Gasket retainer pins pilot line blocked; gasket will be ran with ROV.}</i>		/ Dec-09	N/A		
150	After all wellbore testing is complete, perform the predictive unlocking test. Record the date and pressure in Table I. When locked with 1,500 psi, verify the DWHC connector unlocks at 500 psi or less. Note: Cameron is not sure of this number. The best approach to determine the base line when new or after rebuild and ensure the unlock pressure does not drastically increase.		O Dec-09	N/A		

ID	Assessment Point	Reference	Previous Status	Current Status	Inspection Method	Comments
151	Verify Cameron's recommended secondary lock is present. One method is to use a pilot operated check valve in lock circuit. Another method is to maintain an active pressure in the connector's lock circuit. A maximum pressure of 500 psi lock pressure should be applied after the connector has been locked with normal operating pressure. <i>{Apr-06 Unlocked 500 psi with primary unlock using control system (500 psi low as could go on system).}</i>	*Cameron EB #842M, Rev B1 and 687C	C Dec-09	N/A		
152	If the connector has been disassembled, perform an unlocking test. Any unusual noises could be an indication that the collet fingers have been installed out of sequence. It is imperative that the segments be kept in sequence. Check the collet fingers for damage and/or excess corrosion.	*WEST ITP #23, Cameron Model HC Connectors	N/A Dec-09	N/A		
153	Compare connector stroke both on and off the stump or mandrel. The "off stump" stroke should be at least .188" greater than the "on stump" stroke. <i>{Apr-06 Off stump 1.355" On stump 1.080" Difference .275"}</i>	*Cameron EB #831M	O Dec-09	N/A		
154	Verify that a jetting action occurs when a water hose is connected to the flush ports.		O Dec-09	N/A		
155	Visually inspect AX ring groove condition prior to using/pressure testing. Verify surface finish of the stainless steel ring groove to be 32 RMS or better.		C Dec-09	N/A		
156	E.2.6: Valves	*WEST ITP #26, Subsea Gate Valves - General				
157	WEST considers the requirement contained in IADC Deepwater Well Control Guidelines, Section 3.7.2.6 to disassemble and inspect the failsafe valves annually to be excessive. These valves should be disassembled and inspected on a maximum 24 month schedule. Record dates in Table 1.	*VALVEHISTORY	C Dec-09	/	I	It is recommended that Transocean verify that all stack mounted failsafe valves be disassembled and inspected on a maximum 24 month schedule.

ID	Assessment Point	Reference	Previous Status	Current Status	Inspection Method	Comments
158	<p>Document the location and designation of the lowermost valve block. The lowest choke inlet should not be below the lowermost ram. Verify procedures are in place, governing the use of outlets located below the lowermost ram.</p> <p>a. US Waters: Verify the choke line outlets are above the lowermost ram. A kill line outlet may be installed below the lowermost rams.</p> <p>b. International Waters: "The placement and limitations of an outlet below the lower ram should be evaluated. It should only be used as a kill line for monitoring pressures, and never used as a choke line except as a means of total last resort." <i>[Apr-06]</i></p>	<p>*MMS CFR Title 30, Chapter II, Section 250.443, Paragraph (d) *IADC Deepwater Well Control Guidelines, Section 3.1.4</p>	C Dec-09	C	V	
159	<p>Verify procedures are in place to vent the valve body cavity prior to any disassembly. This applies to any valve regardless of manufacturer. CAUTION: Heavy grease typically used in the valve can cause a false indication of no pressure in the cavity.</p>	<p>*Cameron PA #1816056 and PA #44</p>	C Dec-09	C	D	
160	<p>If the valves in use would normally require a close assist circuit, this requirement may be waived if the following criteria are met:</p> <ol style="list-style-type: none"> 1. The valves must have positive close pressure applied, not just spring closure. The exception is that positive close pressure will not be required if the valve is a wellbore pressure assist close valve and rig procedures are in place to verify spring condition be proven between wells. 2. The rig has an EDS system that applies closing pressure to the valves in the event of an EDS. 3. The rig has a secondary intervention system such as a deadman that applies close pressure to the valves in the event of riser failure or unintentional disconnect. 4. It is not a regulatory requirement. <i>[Apr-06 Use WOM.]</i> 		C Dec-09	C	T	

ID	Assessment Point	Reference	Previous Status	Current Status	Inspection Method	Comments
161	Review PM lubricate valves before BOP run, ensure wellbore test on stump conducted to MWP.		C Dec-09	C	V, T	Lubricated all valves with Magnaseal and wellbore pressure tested to MWP.
162	Review PM to ensure valves inspection completed < 2 years ago, lubricate valves before BOP run, MWP wellbore test.		C Dec-09	/	D	It is recommended that Transocean verify that all stack mounted failsafe valves be disassembled and inspected on a maximum 24 month
163	Ensure seals in valves and warehouse stock are latest revision (Niton 95 vs 90)		C Dec-09	O		
164	Verify latest revision installed (back up ring modified with 45 deg bevel and thickness reduced) and old version removed from warehouse (Seat retainer).		C Dec-09	C		
165	Conduct operator test to MWP prior to BOP run.		C Dec-09	O		
166	Verify spring only test is performed on all valves.		O Dec-09	C	T	
167	E.2.6.1: WOM Failsafe Valves					
168	During testing, verify that the stem packing has been tested by body testing the valve with the gate half open.	*WEST ITP #43, WOM Magnum Gate Valves	C Dec-09	C	T	
169	Unseat or remove the grease fitting (test screw) prior to pressure testing. Monitor the test screw port for leakage during wellbore testing to ensure the valve is achieving an upstream seal.	*WEST ITP #43, WOM Magnum Gate Valves	C Dec-09	C	T	
170	Ensure an appropriate lubricant/filler grease is used for the expected valve service. Magnaseal is currently recommended by WOM.	*WEST ITP #43, WOM Magnum Gate Valves	C Dec-09	C	V	Magnaseal was used.
171	Verify the revised seat retainer backup rings are available in spare parts for all magnum subsea valves.	*WOM SV #0008	O Dec-09	O		

ID	Assessment Point	Reference	Previous Status	Current Status	Inspection Method	Comments
172	On WOM valves with depth compensators on the operator verify the compensator is properly precharged prior to running the stack. An incorrectly precharged compensator will cause the valve to become inoperable subsea.			N/A		Failsafe valves do not have compensating chambers. DM May-10
173	Verify the new Inconel retainer snap rings, PNs BY-1314 and BY-1319, are being installed as part of the normal maintenance process. Old style retainer rings in the warehouse should be discarded and replaced with the new style.	*WOM SV #0006	O Dec-09	O		
174	Verify latest available spring is installed. The current spring is uncoated. <i>{Apr-06 Black in color, not coated UIC, spring pulled and inspected.}</i>	*MK04	O Dec-09	O		
175	E.2.7: Choke and Kill Lines and Hoses	*HOSESHISTORY				
176	Verify that where rigid lines are used, target flanges are installed on short radius pipe bends (R/d<10), 90 degree bends, elbows and tees in the direction of flow.	*API RP 53, 3rd Edition, Section 11.3.i.1	O Dec-09	O		
177	Check the manufacturer's written specification for the minimum bend radii (MBR) at the rated working pressure to ensure that the choke and kill flexible lines meet the manufacturer's recommendation. <i>{Apr-06 Use hard pipe.}</i>	*API RP 53, 3rd Edition, Section 11.i.2; API Spec 16C, 1st Edition, Section 9.14.8	N/A Dec-09	N/A		
178	Verify the auxiliary lines flex loops or hoses on the LMRP will not interfere with any other components during movement of the flex joint in any direction. For DP rigs, consider marking the upper annular cap to monitor for any rotation. In the case of Cameron D annulars, consider installing anti-rotation device(s).	*CA07	C Dec-09	C	V	
179	Verify the manufacturer of choke and kill flexible hoses and record the applicable data in Table II of this ATP.	*API Spec 16C, 1st Edition, Sections 1.2.1 and 9.14	O Dec-09	C	V	

ID	Assessment Point	Reference	Previous Status	Current Status	Inspection Method	Comments
180	Visually inspect choke and kill hoses: -Outer jacket properly attached at both end fittings. -Any outer jacket damages not detrimental to underlying layers. -End terminations. <i>{Jun-09 Choke hose damaged outer jacket.}</i>	*API RP 53, 3rd Edition, Section 18.10.2 *MMS CFR Title 30, Chapter II, Section 250.446, Paragraph (a)	O Dec-09	/	V	All moonpool hoses outer jackets are damaged and the hoses should be replaced. See Daily Report #3. DM May-10
181	If the auxiliary lines on the LMRP are flexible loops made of bent rigid pipe, verify that procedures are in place to prevent debris accumulating in the bends, including circulating through an open valve prior to test.	*CAR 03-02	O Dec-09	O		
182	Verify that moonpool drape hoses have safety slings properly installed. <i>{Item not checked since before Aug-05.}</i>	*IADC Safety Alert 00-24	C Dec-09	/	V	No safety slings are installed. See Daily Report #3. DM May-10
183	Ensure that end connections on hoses are flanged. Threaded pipe connections are not permitted for choke line service.		C Dec-09	C	V	
184	E.2.8: BOP Handling System					
185	Check mechanical, electrical and wire rope condition.		N/A Dec-09	N/A		
186	Verify safe procedures are in place for changing wellhead and riser connector gaskets.	*IADC Safety Alert 99-26	C Dec-09	C	V	
187	Verify the crane load test documentation is available onboard and review. Verify test dates within an acceptable annual period.	*API RP 7L, 1st Edition, Section 5.4	O Dec-09	N/A		
188	E.2.8.1: Gantry Crane					
189	Review manufacturer's documentation and third party inspection reports. Verify all is available and in order.		N/A Dec-09	N/A		
190	Check mechanical and electrical installation.		N/A Dec-09	N/A		
191	Witness performance tests for full set of operations.		N/A Dec-09	N/A		

ID	Assessment Point	Reference	Previous Status	Current Status	Inspection Method	Comments
192	Inspect condition of wire rope, installation date and certificate number: Fwd. Hoist Wire Date Installed Certificate No.		N/A Dec-09	N/A		
	Aft Hoist Wire Date Installed Certificate No.					
193	Verify the crane load test documentation is available onboard and review. Verify current.		N/A Dec-09	N/A		
194	Check spare parts against manufacturer's recommended list.		N/A Dec-09	N/A		
195	Section E.3: BOP Control System	*CONTROLSYSTEM HISTORY				
196	E.3.1: Documentation & Procedures	*WEST ITP #48, Subsea Control Svstems				
197	Obtain and report history of hot line supply, pod hose and pilot line failures. <i>{Apr-06 All new in 2004, replaced after riser parted, hot line and yellow and blue MUX cable, no pilot lines.}</i>	*API RP 53, 3rd Edition, Section 18.13.3	O Dec-09	O		
198	Verify the rig is equipped with written emergency disconnect procedures, which account for various tubulars being in the BOP bore, peculiarities in the BOP and control equipment, and characteristics of position keeping or mooring equipment.	*API RP 16Q, 1st Edition, Section 4.4.4.2	C Dec-09	C	V, D	
199	Verify measures have been implemented to lock out any LMRP disconnect (hydraulic or electro-hydraulic) so that the LMRP can be disconnected only as the result of a deliberate act. Measures can include the use of electronic exclusion switches and bolted covers. Any computer based LMRP disconnect function (EDS) should also be equipped with an effective lock-out.	*MMS NTL No. 2000-G07 dated February 22, 2000; API Spec 16D, 2nd Edition, Section 4.3.2.3	C Dec-09	C	V, T	

ID	Assessment Point	Reference	Previous Status	Current Status	Inspection Method	Comments
200	The MMS considers a backup BOP actuation system (such as an ROV) to be an essential component of a deepwater drilling system and, therefore, expects OCS operators to have reliable backup systems for actuating the BOP in the event that the marine riser is damaged or accidentally disconnected.	*MMS Safety Alert No. 186	C Dec-09	C	V, T	
201	Performing a wellbore test after actuating the BOP (using the backup system) best proves the reliability of the function. (Even if not in MMS waters, this should still be considered.) <i>{Item not checked since before Aug-05.}</i>	*MMS Safety Alert No. 186	O Dec-09	/	I	Wellbore pressure tests not performed after EDS or deadman. Wellbore pressure tests should be done following an ROV panel function test.
202	Check fluid sample inspection reports (NAS rating should be less than 10)		O Dec-09	C	D	The rig sends in oil samples every thirty days.
203	E.3.2: Pumping & Storage Equipment					
204	Visually inspect the accumulator bottles and related control system piping for significant loss of wall thickness from external corrosion.		C Dec-09	C	V	
205	Check that strainers on control unit are of size recommended by manufacturer.		O Dec-09	O		
206	Isolation and bleed-down valves should be provided on each accumulator bank for checking precharge pressure or draining accumulators back to the reservoir.	*MMS CFR Title 30, Chapter II, Section 250.442, Paragraph (c) *API RP 53, 3rd Edition, Section 13.3.8	C Dec-09	C	V	
207	Accumulator system should be arranged such that the loss of an individual accumulator and/or bank should not result in more than 25% of accumulator system capacity.	*API Spec 16D, 2nd Edition, Section 5.3.3	C Dec-09	C	V	
208	Ensure subsea accumulators have isolation and dumping capabilities.	*MMS CFR Title 30, Chapter II, Section 250.442, Paragraph (c) *API RP 53, 3rd Edition, Section 13.3.4	C Dec-09	C	V, T	

ID	Assessment Point	Reference	Previous Status	Current Status	Inspection Method	Comments
209	Report condition of control fluid, including brand name and percentage of mix fluid, pH, cleanliness, bacteria content, and National Aerospace Standard (NAS) cleanliness standard.	*WEST ITP #93, Procedure for Testing the BOP Control System Fluid	O Dec-09	C	D	Documentation was reviewed and acceptable.
210	Obtain a sample of control system function fluid from downstream of the pod as soon as possible after retrieving the stack for independent third party fluid analysis. A minimum of eight ounces is required. Return fluid sample to WEST for analysis.	*WEST ITP #93, Procedure for Testing the BOP Control System Fluid	O Dec-09	O		
211	Verify the usable control system fluid reservoir capacity is at least equal to the total accumulator storage capacity. Neat fluid and glycol tanks should also have sufficient capacity. Verify necessary alarms, vents and cleanout ports. <i>{Apr-06 1,000 gallons.}</i>	*API Spec 16D, 2nd Edition, Section 4.2.4.3.1; API RP 53, 3rd Edition, Section 13.6.2	O Dec-09	C	V	
212	Each pump system should be protected from over-pressurization by a minimum of two devices to limit the pump discharge pressure, usually a pressure limit switch and a pressure relief valve. Check both systems and comment.	*API RP 16D, 2nd Edition, Section 5.1.2.3; API RP 53, 3rd Edition, Section 13.4.4; API RP 64, 2nd Edition, Section 5.8.5.2	O Dec-09	/	V	The pressure relief valves do not have calibration tags affixed. The pressure relief valves should be replaced with recently calibrated valves. DM May-10
213	Function accumulator charging pumps (triplex and air) independently to determine effective operation. Report the pressure switch setting of the pumps. Report relief valve setting. <i>{Mar-07 Pump 1 - On 4500 psi, Off 5000 psi. Pump 2 - On 4600 psi, Off 5000 psi. Pump 3 - On 4700 psi, Off 5000 psi. Relief Valve Setting - 5500 psi.}</i>		O Dec-09	C	T	Pump 1 - On 4,500 psi, Off 5,000 psi. Pump 2 - On 4,600 psi, Off 5,000 psi. Pump 3 - On 4,700 psi, Off 5,000 psi. Relief Valve Setting - 5,500 psi.
214	E.3.3: Pressure Vessels and Pressure Relieving Devices					
215	Verify that all pressure vessels, including hydraulic accumulators, are inspected according to an established procedure.		O Dec-09	O		

ID	Assessment Point	Reference	Previous Status	Current Status	Inspection Method	Comments
216	Verify that the period between internal inspections does not exceed one half of the estimated remaining life of the vessel, based on corrosion rate or 10 years, whichever is less. Internal field inspections of new vessels are not required, as long as a manufacturer's data report assuring that the vessels are satisfactory for their intended service is available.	*API RP 510, Sections 6.1 and 6.4; WEST ITP #60, Pressure Vessels and Pressure Relieving Devices	O Dec-09	O		
217	Verify that each pressure vessel is examined or tested every 5 years. Special purpose vessels shall be tested at intervals coinciding with the Certificate of Inspection renewal interval, not to exceed twice in 5 years with no interval to exceed 3 years. Pressure vessels, which cannot be internally examined, must be hydrostatically tested to 1.25 x the working pressure, twice in 5 years with no interval to exceed 3 years. Pressure vessels found with defects, internal or external, must be hydrostatically tested to 1.5 x the working pressure. Note: For specific details, refer to the quoted reference document.	*Coast Guard/DOT CFR Title 46 Chapter I Section 61.10-5; WEST ITP #60, Pressure Vessels and Pressure Relieving Devices	O Dec-09	O		
218	Ensure that safety relief valves have been tested according to an established procedure. The test interval shall be twice in 5 years with no interval more than 3 years. <i>{Aug-05 Relief valves Due Jun-05 - scheduled for next EOW.} {Apr-06 All APV pulled to recertify.}</i>	*CG/DOT CFR Title 46 Chapter I Section 61.10-5 (i); WEST ITP #60, Pressure Vessels & Pressure Relieving Devices; API RP 576, 2nd Edition	O Dec-09	/	V	The HPU pressure relief valves do not have calibration tags affixed. The pressure relief valves should be replaced with recently calibrated valves. DM May-10
219	E.3.4: Regulators					
220	Verify all regulators supplied by rig air, and without a secondary source of pneumatic supply, are equipped with manual overrides or, alternately, other devices provided to ensure capability of hydraulic operations if rig air is lost. <i>{Aug-05 Backup nitrogen supply.}</i>	*API RP 53, 3rd Edition, Section 18.3.8	C Dec-09	C	V	Nitrogen backup system installed. DM May-10

ID	Assessment Point	Reference	Previous Status	Current Status	Inspection Method	Comments
221	Verify that pod-mounted manifold regulator pilot line surge bottles are precharged to manufacturer's recommended pressure, plus seawater hydrostatic.	*API Spec 16D, 2nd Edition, Section 4.3.3	C Dec-09	C	V	
222	Verify regulators operate smoothly throughout their entire range.		C Dec-09	/	V, T	The HP casing shear ram regulator is leaking and needs to be rebuilt.
223	E.3.5: Reaction Times					
224	Verify that the control system for a subsea BOP stack is capable of closing each ram BOP in 45 seconds or less and each annular in 60 seconds or less.	*API Spec 16D, 2nd Edition, Section 5.2.1; WEST ITP #12, Annular Preventer - General; API RP 53, 3rd Edition, Section 13.3.5	C Dec-09	C	T	
225	E.3.6: BOP Stack Hosing					
226	Identify potential single point failures that could cause the loss of redundancy and/or independent systems due to hose and shuttle valve placement. Address if it is practical to modify or replace hose with hard piping for improved reliability.	*API RP 53, 3rd Edition, Section 13.1	O Dec-09	O		
227	Verify that all hoses for or on the BOP stack have been pressure tested to 1.5 x maximum system pressure.	*WEST ITP #1, BOP Stack Hoses	O Dec-09	C	V, T	New hoses were pressure tested to 7,500 psi.
228	Verify all hoses are routed to prevent excessive bending or friction points on outer cover.	*WEST ITP #1, BOP Stack Hoses	O Dec-09	C	V	
229	Check the quality plan for BOP stack hose fabrication procedures as well as for renewing existing hoses.	*WEST ITP #1, BOP Stack Hoses	O Dec-09	O		
230	Ensure that all hose fittings without backup nuts have been installed with the hose in a relaxed state.	*MC78	O Dec-09	C	V	
231	E.3.7: Control Panels					
232	Verify that the electrical control units are being supplied with electrical power from an uninterruptible power supply. <i>{Apr-06 UPS was tested Feb-06.}</i>	*API RP 53, 3rd Edition, Section 14.4.1	O Dec-09	O		

ID	Assessment Point	Reference	Previous Status	Current Status	Inspection Method	Comments
233	Verify that there is at least one operable remote BOP control station in addition to the one on the drilling floor. <i>{Aug-05 Drill floor, Subsea shop, OIM office.}</i>	*MMS CFR Title 30, Chapter II, Section 250.443, Paragraph b	C Dec-09	C	V, T	
234	Check to ensure the control station is in a readily accessible location away from the drill floor.	*MMS CFR Title 30, Chapter II, Section 250.443, Paragraph b	C Dec-09	C	V	
235	Remote BOP control panels shall be capable of applying 3,000 psi to the close side of the shear rams.		C Dec-09	C	V	
236	Check remote panels to ensure pressure readings coincide with main BOP control skid gauges.	*MMS CFR Title 30, Chapter II, Section 250.442, Paragraph C *API RP 53, 3rd Edition, Section 13.5.1	C Dec-09	C	V, T	
237	Verify BOP schematic on the panel accurately depicts ram/valve layout.	*API Spec 16D, 2nd Edition, Sections 5.2.7 and 5.2.8	C Dec-09	C	V	
238	Verify the lamp test function. Ensure all bulbs are operational and should be luminous enough to easily be seen in ambient lighting conditions.		C Dec-09	C	V	
239	Ensure the enable button is connected to all functions. Verify no functions operate without first depressing the enable push-button.	*API Spec 16D, 2nd Edition, Section 4.3.3.1	C Dec-09	C	T	
240	Function test each function on the panel and record any defects: open to block, close to block, open to close, close to open. Verify memory circuit is operational. <i>{Apr-06 Functioned from OIM panel and drillers. Dry fire no supply pressure. Did not do stack and riser stingers; these have been done from subsea panel and will not do from remote, nor LMRP connector.}</i>		C Dec-09	C	V, T	
241	Verify circuits retain memory in the event of momentary primary power interruptions.	*API RP 53, 3rd Edition, Section 14.4	O Dec-09	O		

ID	Assessment Point	Reference	Previous Status	Current Status	Inspection Method	Comments
242	Check proper operation of the flowmeter readout and reset. Verify low flow functions are accurately recorded then comment.	*API Spec 16D, 2nd Edition, Sections 5.2.7.e and 5.2.8.e	C Dec-09	C	V, T	
243	Verify control panel is protected by circuit breaker in each main power connection.		C Dec-09	C	V	
244	E.3.8: Alarms					
245	Verify that all remote control stations are fully operational. This means that all installed visual indicators, pressure gauges and audible alarms should function as designed. Note any discrepancies for each panel.	*API Spec 16D, 2nd Edition, Sections 5.2.7 and 5.2.8	C Dec-09	C	V, T	
246	E.3.9: Reel Structure and Drive					
247	Inspect all reel drive motors and ensure the following:					
248	a. Motor lubricant levels are as per manufacturer's recommendations <i>{Apr-06 PM completed on reels earlier by subsea engineers.}</i>		O Dec-09	O		
249	b. Motor and chain are aligned with main sprocket		O Dec-09	O		
250	c. Jacking bolts are installed at motor		O Dec-09	O		
251	d. Sprocket teeth are in good condition		O Dec-09	O		
252	e. Chain is properly tensioned, lubricated and a proper guard is installed		O Dec-09	O		
253	f. Sprocket set screws are tight		O Dec-09	O		
254	g. Reel manual locks engage into reel properly		O Dec-09	C	V	
255	h. Brakes are adequate for expected service		O Dec-09	C	V	
256	Visually inspect reel mounting welds.		O Dec-09	O		
257	Visually inspect drum, shaft, bearings and keepers.		O Dec-09	O		
258	Verify air line filter/separator and lubricator are functional.		O Dec-09	O		
259	Check for hydraulic and air leaks.		O Dec-09	O		
260	Verify that the level wind, if installed, is operational and adequate to spool cable or hose without damage.		O Dec-09	C	V	
261	Verify the operator has a good view of moonpool operations from the control station.		O Dec-09	C	V	

WEST ©

ID	Assessment Point	Reference	Previous Status	Current Status	Inspection Method	Comments
262	E.3.10: Secondary Intervention Systems					
263	Record the type of secondary intervention systems installed. Record in Table I.	*WEST ITP #169, Secondary Intervention	O Dec-09	C	I	
264	Note any known system limitations, interlocks with other systems and means of redundancy, if any. Such limitations could be water depth and battery life. <i>{Apr-06 Battery life, batteries upgraded on pod 3 which completes upgrade for batteries on all pods.}</i>		O Dec-09	O		
265	Identify any failures of the system, such as inadvertent activation or failure to function.		O Dec-09	C	T	
266	If a deadman type system is installed, state if it will also fulfill the requirements of an Autoshear system. <i>{Apr-06 Yes.}</i>	*WEST ITP #169, Secondary Intervention	O Dec-09	C	T	
267	E.3.10.1: ROV (Remote Operated Vehicles)	*Hot stabs ROV				
268	Verify that, for a multi-function system, an operating panel is mounted on the BOP stack in an accessible location and clearly labeled for identification by the ROV television cameras. Record all functions available in Table I. Provide pictures of the panels.	*MMS Conditions of Approval Effective 01-Dec-2000 *API Spec 16D, 2nd Edition, Section 5.8.1	O Dec-09	C	V	
269	Verify that any blind subs or dummy plugs used are ported to allow venting.		C Dec-09	C	V	
270	Record ROV pumping information in Table I.		O Dec-09	C	D	
271	Verify that procedures require the appropriate hot stabs to be maintained on the ROV during routine surveillance in the event they are needed.		C Dec-09	C	I	
272	State the time required to close the shear ram using only the ROV pump. Determine if the ROV can maintain required closing pressure on the shear ram operator while simultaneously engaging the ram locking device. <i>{Apr-06 30 to 40 gal depending on 22" or 19" operators, 10 to 15 minutes at 3 GPM.} {Jun-09 Same.}</i>		O Dec-09	O		Did not activate by using the ROV. Hydril MPL locks are used. 30 to 40 gal depending on 22" or 19" operators, 10 to 15 minutes at 3 GPM.

ID	Assessment Point	Reference	Previous Status	Current Status	Inspection Method	Comments
273	E.3.10.2: Automatic Intervention	WEST ITP #169, Secondary Intervention				
274	Record all functions that are included in the Deadman/Autoshear/AMF s system in Table I.		O Dec-09	O		
275	Specify if the system is software controlled (electronic) and/or hydraulically controlled. <i>{Mar-07 Software controlled.} {Jun-09 Same.}</i>		O Dec-09	C	I	
276	E.3.11: Control System - General					
277	If problems have been encountered with hose or tube fittings loosening while in use, the problem may be inadequate support brackets. Verify tubing and hoses are properly supported in accordance with NASA Specification KSC-SPEC-Z-0008C.	*NASA Specification KSC-SPEC-Z-0008C	O Dec-09	C	V	
278	If the control system has a hydraulic conduit, the flexible hydraulic hose in the moonpool, including end connections, should be flame retardant. <i>{Mar-07 Item not checked. Unable to verify this.}</i>	*API RP 53, 3rd Edition, Section 13.9.2	O Dec-09	/	V	All moonpool hoses outer jackets are damaged and the hoses should be replaced. See Daily Report #3. DM May-10
279	Multiplex Controls					
280	Flow restrictors should be installed in the function lines between the pods and shuttle valves on control systems having a conduit or accumulator supply pressure greater than 3,000 psi.	*Anomaly M-C-23	O Dec-09	/	V	No flow restrictors are installed.
281	Shuttle valves on control systems using a supply pressure greater than 3,000 psi should be of the dampened variety. If the shuttle valves are Gilmore Mark III valves, they can be easily converted to a dampened shuttle valve. To obtain the conversion kit, which includes the new shuttle and end caps and all necessary seals, order by part number XXXXX.3RK	*WEST ITP #174, Rev 2, Gilmore Shuttle Valves	O Dec-09	C	V	

ID	Assessment Point	Reference	Previous Status	Current Status	Inspection Method	Comments
282	Verify that when the primary power source is lost, electrical power (excluding the pumps) is supplied from one or more uninterruptible power supplies, with backup battery capabilities to operate the controls for at least two hours. Verify all UPS alarms are properly issued. <i>{Apr-06 UPS tested in Feb-06.}</i>	*API Spec 16D, 2nd Edition, Section 5.4.3; WEST ITP #128, MUX Controls Between Well Maintenance Checklist	O Dec-09	O		
283	If applicable, Meggar test all solenoids to solenoid valve housing with a Meggar and at a voltage specified by the manufacturer. If no voltage is specified, use a 250 Vdc Meggar. Note: Any readings below 100 MegaOhms should be verified acceptable by comparison to an established baseline reading or compared with a new solenoid coil.	*WEST ITP #128, MUX Controls Between Well Maintenance Checklist	O Dec-09	O		
284	Check the insulation resistance for all pressure transducers with a volt-ohm meter. Measure the resistance between one conductor and the shell or sub plate, with the other conductor open circuited. All readings shall exceed 100 MegaOhms.	*WEST ITP #128, MUX Controls Between Well Maintenance Checklist	O Dec-09	O		
285	Verify that all solenoid/shear valves activate and deactivate properly. This test should also include operation from the backup E-H (Electro-Hydraulic), if equipped.	*WEST ITP #128, MUX Controls Between Well Maintenance Checklist	O Dec-09	C T		
286	Verify that all functions in the auto EDS (electronic disconnect sequence) operate properly and fire at the correct time. <i>{Mar-07 Mode 1 - 19 seconds, Mode 2 - 33 seconds, Mode 3 - 33 seconds.} {Apr-06 All EDS 1, 2, 3 were dry fired by the subsea engineer.}</i>	*WEST ITP #128, MUX Controls Between Well Maintenance Checklist	O Dec-09	C	T	Mode 1 - 20 sec., Mode 2 - 31 sec., Mode 3 - 32 sec.
287	Verify that the "Deadman" function, if equipped, will operate if there is a concurrent loss of the BOP control electrical power and the hydraulic power to both pods.	*WEST ITP #128, MUX Controls Between Well Maintenance Checklist	O Dec-09	C	T	
288	Verify the electrical and mechanical integrity of all cables, connectors, and winches. <i>{Apr-06 Check list completed by ETs. All PBOF connectors tested with helium at 30 psi for 15 min.}</i>	*WEST ITP #128, MUX Controls Between Well Maintenance Checklist	O Dec-09	O		

ID	Assessment Point	Reference	Previous Status	Current Status	Inspection Method	Comments
289	Verify the electrical and mechanical integrity of the subsea vessels, the subsea terminations, and the umbilical cable. <i>{Apr-06 Opened SEM, seals were pressure tested.}</i>	*WEST ITP #128, MUX Controls Between Well Maintenance Checklist	O Dec-09	O		
290	Verify the electrical integrity of the Driller's Panel, the Toolpusher's Panel, and, if necessary, the CCU (central control unit). This integrity check should also include proper operation of the purge systems incorporated in the hazardous areas, i.e., the Driller's Panel. <i>{Apr-06 Functions were dry fired from drillers and OIM. All four SEMs were done from yellow and blue pod from subsea panel. Touch screen panel on drill floor.}</i>	*WEST ITP #128, MUX Controls Between Well Maintenance Checklist	O Dec-09	O		
291	Verify the optical integrity of all fiber optic cables, slip rings, and connectors where applicable.		O Dec-09	O		
292	Insure proper calibration of all regulator transducers and other analog devices.	*WEST ITP #128, MUX Controls Between Well Maintenance Checklist	O Dec-09	C	T	
293	Verify that the data logging system for the MUX control system is operational during surface tests and all subsea operations.	*WEST ITP #126, BOP Control System Data Logging	C Dec-09	C	T	
294	ROV intervention for the LM RP connector should include the ability to unlatch mini connectors when disconnecting the LM RP. <i>{Mar-07 Choke and kill line stabs retract.}</i>		C Dec-09	C	T	Choke and kill stabs retract.
295	Check the proper operation of the ERA and ESA.	*WEST ITP #128, MUX Controls Between Well Maintenance Checklist	O Dec-09	O		
296	If Gilmore pilot operated check valves, PNs 25100 and 25101, are in use, verify they have been upgraded in accordance with Gilmore PIB #100-0401-001.	*Gilmore PIB #100-0401-001	O Dec-09	O		

ID	Assessment Point	Reference	Previous Status	Current Status	Inspection Method	Comments
297	Function test the stack with the MUX control system from all operator stations. <i>{Mar-07 All functions "dry fired" on all SEMs from all four touch screens on drill floor.}</i>	*WEST ITP #128, MUX Controls Between Well Maintenance Checklist	C Dec-09	/	I	Not function tested from drillers or toolpushers panel. We were informed that this would be done.
298	E.3.11.1: MUX Cables and Connections					
299	Verify that the slip ring contact assemblies are of a non-oxidizing material suitable for the surrounding atmosphere. Manufacturer documentation is to be reviewed to confirm approved for climate.	*API Spec 16D, 2nd Edition, Section 5.4.7.3	O Dec-09	O		
300	Verify slip rings located in hazardous locations, as defined in API RP 500 and IEC 529, are certified as suitable for service in the hazardous location in which they are installed.	*API Spec 16D, 2nd Edition, Section 5.4.7.3	O Dec-09	O		
301	Visually inspect the MUX cable for armor damage.	*WEST ITP #128, MUX Controls Between Well Maintenance Checklist	O Dec-09	O		
302	Determine if moonpool sheaves are adequate to handle MUX cables without damaging them.	*WEST ITP #128, MUX Controls Between Well Maintenance Checklist	O Dec-09	C	V	
303	Megger the MUX umbilical cable using 500 Vdc. Umbilical should not be mated to the flanged electrical receptacle (FCR) nor connected to the slip ring assembly (SRA). All Meggar readings should be greater than 100 Meg Ohms. <i>{Apr-06 Have ground fault indicators which constantly check cables in the Communications and Distribution Panel B.}</i>	*WEST ITP #128, MUX Controls Between Well Maintenance Checklist	O Dec-09	O		
304	Check that the electrical plug (CCP) back shell and PBOF cables are filled with manufacturer specified oil and or topped off with sufficient dielectric oil (i.e., DC 200 silicon oil).	*WEST ITP #128, MUX Controls Between Well Maintenance Checklist	O Dec-09	O		

ID	Assessment Point	Reference	Previous Status	Current Status	Inspection Method	Comments
305	E.3.11.2: Cameron Multiplex Controls	*Cameron Product Advisory #22060; WEST ITP #45, Cameron Control Systems				
306	Cameron control components should be checked to verify they have been upgraded to the latest design/revision per Cameron Product Advisory #22060. Upgrade kits should be available. Also check the following:	*Cameron Product Advisory #22060	O Dec-09	O		
307	a. Verify that the O-rings in the seal rings of the 1" valves have been upgraded from 70 durometer to 90 durometer.		O Dec-09	O		
308	b. If ceramic seal plates have a history of failures, verify stainless steel plates have been installed in the 1/4" pod valves and 1-1/2" regulators.	*Cameron EB #861C; CC06	C Dec-09	O		
309	c. If 1/2" biased shuttle valves have a balanceboot, ensure that it is filled completely with grease. If leakage is observed in the valve, verify that swarf cut backup rings have been installed in place of uncut backup rings.		O Dec-09	N/A		
310	d. Verify the latest upgrade is installed in any Cameron POCVs. The upgrade seat is tan in color on the 3/4" valve.		O Dec-09	N/A		
311	e. Verify that the correct seats are installed in Cameron float type accumulators. The upgrade seat is tan in color.		O Dec-09	N/A		Bladder type bottles used.
312	f. Verify that the correct seats are installed in Cameron non positive seal shuttle valves. The upgrade seat is tan in color.		O Dec-09	O		
313	g. Verify that the diverter packer circuit is in compliance with Cameron EB #869 C.	*Cameron EB #869C	O Dec-09	O		
314	If Cameron float-type accumulators are in use and the floats have a history of hanging up or sinking, the accumulators should be replaced with an alternate design.	*CC04	O Dec-09	N/A		

ID	Assessment Point	Reference	Previous Status	Current Status	Inspection Method	Comments
315	The common vent manifold of the MUX pod solenoid valves has been identified as a cause for concern on past risk assessments. While there have been no known failures, the potential exists for a blockage creating backpressure which may cause the inadvertent operation of a function. To mitigate the risk, replacement of the manifold with U-tubes on each individual valve or additional outlets in the manifold should be considered.	*CC108	O Dec-09	C	V	
316	If the pod is equipped with the older style type 15 solenoid valves (PN 223290-15), they may be replaced with the newer type 63 valves (PN 223290-63). It is recommended that solenoid valves be tested electrically for coil pull in and drop out voltage while under full working pressure. A software upgrade is required before a larger number of type 63 valves can be installed. Cameron recommends that rigs currently equipped with type 15 solenoids pre-install the driver software before having to replace the solenoids. Note: Type 15 valve stock is no longer being replenished.	*CC11; Cameron Technical Query #223000-65-019	O Dec-09	O		
317	If P/N 2185014-04, 5,000 psi pod-mounted accumulator supply valve is in use, check if there is a history of the nitrided seal plate corroding. Verify the valves are disassembled and checked on a regular basis, possibly between wells.	*CC110	O Dec-09	O		
318	Determine if the PBOF connectors are the revised design with test ports.	*CC40	C Dec-09	C	D	
319	Ensure that procedures are in place to avoid arming both AMF cards on one pod at the same time. Simultaneous activation could cause the AMF sequence to shut down prior to completion. <i>{Item not checked since before Apr-06.}</i>	*CC89	O Dec-09	O		

ID	Assessment Point	Reference	Previous Status	Current Status	Inspection Method	Comments
320	If premature failure due to corrosion of pod valve and regulator seal plates is an issue, the rig should establish procedures to flush out seawater immediately after retrieving the stack by operating all pod functions, and functioning again if on the surface over seven days. Additionally, a phased replacement of existing components with the new Cameron premium valves should be considered.	*CC15	O Dec-09	C	I	
321	If quick dump valves are in use in any control circuit, verify the latest version, Cameron PN 309076-01, is installed. Verify metal-to-metal seats.	*CC75	O Dec-09	O		
322	Verify the bolts retaining the pod stinger seals to the energize piston are intact and tight.	*CC103	O Dec-09	O		
323	Verify procedures are in place to test the AMF system between wells. Test the system.	*Cameron Battery Life Expectancy Report	O Dec-09	C	T	Deadman system
324	Verify that the ROV primary and secondary unlatch circuit for the LMRP connector will also de-energize the pod stack stingers prior to unlatching the connector. Failure to do so may result in significant damage to the stingers and/or the female receptacles.		O Dec-09	C	V, I	
325	Verify Mark II control pod electronic power supplies are upgraded.	*Cameron Product Advisory #18040	O Dec-09	O		
326	Ensure handling and inspection procedures for Cameron SEM pie connectors are performed in accordance with Cameron HP #234102-01.	*Cameron HP #234102-01	O Dec-09	O		
327	E.3.12: Subsea TV					
328	Visually inspect the subsea TV camera cable and end terminations for serviceability. Comment.		N/A Dec-09	N/A		
329	Is a spare camera available on the rig?		N/A Dec-09	N/A		
330	Verify proper operation of the subsea TV camera winch brake. This should be operable from the unit as well as remotely.		N/A Dec-09	N/A		

ID	Assessment Point	Reference	Previous Status	Current Status	Inspection Method	Comments
331	Section E.4: Marine Riser System	*RISERHISTORY				
332	E.4.1: Documentation, Procedures and Inspections	*WEST ITP #29, Riser - General; API Spec 16Q, 1st Edition				
333	Verify the results of the riser system design analysis are appended to the riser operating manual. <i>{Item not checked since before Aug-05.}</i>	*API Spec 16Q, 1st Edition, Section 3.3.3	O Dec-09	O		
334	Verify equipment specific procedures, such as verifying correct makeup of joints, are included in the running procedures. <i>{Item not checked since before Aug-05.}</i>	*API Spec 16Q, 1st Edition, Section 4.3.2	O Dec-09	O		
335	Riser handling tools: Verify handling tools have a 25% factor of safety above the maximum hook load. This is required to install the riser and BOP. <i>{Item not checked since before Aug-05.}</i>		O Dec-09	O		
336	E.4.2: Telescopic Joint					
337	"The inner barrel telescopes into the outer barrel and should be bolted or pinned to the outer barrel when handling." When stacks are handled with the telescopic joint extended, verify load capacity. Review inspection frequencies and techniques to ensure the telescopic joint is used within its operating limits.	*API Spec 16Q, 1st Edition, Section 4.6.2	O Dec-09	O		
338	Verify the telescopic joint packers are pressure tested in accordance with the manufacturer's recommendations. <i>{Item not checked since before Apr-06.} {Aug-05 Item not compliant. A leak was noticed on the upper packer on the slip joint. Maintenance procedures could be more aggressive to ensure the reliability of the packers.} {Jun-09 New slipjoint on board the Discoverer Enterprise.}</i>	*API RP 64, 2nd Edition, Section 7.6.2	O Dec-09	O		

ID	Assessment Point	Reference	Previous Status	Current Status	Inspection Method	Comments
339	On DP rigs, procedures are in place to track rotation of the fluid bearing when the vessel heading is changed. The fluid bearing will not follow the rig degree for degree. If residual torque remains in the riser when the wellhead connector is unlocked, the stack may rotate on the wellhead and damage the gasket-sealing surface.		O Dec-09	O		
340	Verify that locking pressure is maintained on the locking dogs at all times when in the stowed position, or that some other failsafe device is used to prevent the dogs from inadvertently unlocking.		O Dec-09	N/A		
341	Ensure safety slings are installed while the ring is stowed, even if a hydraulic lock-out is used.		O Dec-09	N/A		
342	E.4.2.1: Vetco HMF Telescopic Joint	*Vetco Gray PRP				
343	Vetco telescopic joint locking bolts and corresponding threaded holes shall be inspected for corrosion and damage.	*Vetco Field Service Advisory #12	O Dec-09	O		
344	Verify the recommended lubricants are available and used. For moving parts, use Jet Lube Alco EP-731 or equivalents Almagard 3752 or Lubriplate 630AA/930AA. For threads, use Never Seez or equivalent.	Data\Historical Documents\Never Seez_email.doc	O Dec-09	C	V, I	
345	Visually inspect pin and box couplings and hydraulic latch locking cylinders for damage. Repair or replace as necessary.	*Vetco Gray PRP	O Dec-09	O		
346	Verify telescopic joint riser couplings are inspected and maintained the same as the riser joints.	*Vetco Gray Equipment Service Manual	O Dec-09	O		
347	Inspect the auxiliary lines for damage and ensure they are securely attached.	*Vetco Gray PRP	O Dec-09	O		
348	Verify the gap on the telescopic joint auxiliary lines are within Vetco allowables. <i>{Item not checked since before Apr-06.}</i>	*Vetco Gray Equipment Service Manual	O Dec-09	O		
349	Verify coupling protectors are installed on the telescopic joint prior to handling the joint	*Vetco Gray PRP	O Dec-09	O		

ID	Assessment Point	Reference	Previous Status	Current Status	Inspection Method	Comments
350	All subsea drilling equipment, including riser system components, should be washed down with fresh water after recovery from salt water.	*Vetco Gray PRP	O Dec-09	O		
351	Verify the dual packer assembly has not been assembled upside down.	*Vetco Product Advisory #FSA-HO51644	O Dec-09	O		
352	Verify spare parts for the telescopic joint include: 1 set static seals, 2 sets dynamic seals, 3 sets external seals, 3 sets special seals, 2 split packers, 1 solid packer, full set of socket set screws, 2 each socket head cap screws where less than 10 are used, 4 each socket head cap screws where more than 10 are used, hose/fittings as needed and 1 each of any special component or sub-assembly that could cause downtime. <i>{Item not checked since before Apr-06.}</i>	*Vetco Gray PRP	O Dec-09	O		
353	E.4.3: Drilling Riser	*WEST ITP #29, Riser - General; API Spec 16Q, 1st Edition, RP for O&M of Drilling Riser Systems				
354	Check the riser bore for keyseating and record. <i>{Item not checked since before Aug-05.} {Jun-09 No keyseating found on lower two rows of the riser.}</i>	*API Spec 16Q, 1st Edition, Section 4.8.1; WEST ITP #42, Allowable BOP Vertical BOP Keyseating	O Dec-09	O		
355	Verify that hydraulic running tools have a position indicator that clearly shows when the tool is locked and unlocked. <i>{Item not checked since before Aug-05.}</i>		O Dec-09	O		
356	Choke and kill packing should be inspected between each well and verified to be in "as new" condition. Contractor to provide quantity of each auxiliary line seal on board. Remove the auxiliary line seals from 10% of the riser and inspect the seal preps. <i>{Item not checked since before Aug-05.}</i>	*API Spec 16Q, 1st Edition, Sections 4.3.2 and 4.8; WEST ITP #29, Riser - General	O Dec-09	O		

ID	Assessment Point	Reference	Previous Status	Current Status	Inspection Method	Comments
357	Verify there is an adequate number of riser, pups, and spare joints available for the anticipated water depth. <i>{Item not checked since before Apr-06.}</i>	*WEST ITP #29, Riser - General	O Dec-09	O		
358	Visually inspect each riser joint to assure that no lifting eyes or other obstacles are present which will hang up on the diverter housing when running or pulling the riser.	*WEST ITP #29, Riser - General	O Dec-09	O		
359	Inspect riser buoyancy, if used, to ensure that it is not damaged, is securely attached and the thrust collars are properly installed. Ensure guidance is sufficient to prevent damage when going through the rotary.	*WEST ITP #29, Riser - General	O Dec-09	/	V	Riser was visually inspected and damaged buoyancy modules were observed. Damaged thrust collars were also observed. DM-Apr-10
360	Inspect the buoyancy for broken pieces that could fall during handling. Verify that procedures are in place to take broken buoyancy out of service.	*IADC Safety Alert #99-30	O Dec-09	O		
361	Ensure that the main line seals are properly installed and in good condition.	*WEST ITP #29, Riser - General	O Dec-09	O		
362	Verify that protectors are provided for the pin end (and box end if specified by the manufacturer) couplings of each riser joint. Visually inspect the box and pin protectors to ensure they properly protect the sealing surfaces. Ensure that the protectors are installed, as applicable, when riser is being handled.	*API Spec 16Q, 1st Edition, Section 4.7.1; WEST ITP #29, Riser - General	O Dec-09	O		
363	Review the riser handling technique and verify it complies with good oilfield practices and the manufacturer's recommendations.	*API Spec 16Q, 1st Edition, Section 4.7.1	O Dec-09	O		
364	Verify that the rig has storage racks and cradles, and these are being used to restrain and support the riser joints during stored periods.	*API Spec 16Q, 1st Edition, Section 4.7.2	O Dec-09	O		
365	Verify that the rig storage racks do not hinder access to the pin and/or box protectors or covers for maintenance and inspection.	*API Spec 16Q, 1st Edition, Section 4.7.2.d	O Dec-09	O		

WEST ©

ID	Assessment Point	Reference	Previous Status	Current Status	Inspection Method	Comments
366	New riser should have NDE inspections performed in the weld heat affected zones prior to the first well. Cracks have been found on new riser joints from more than one manufacturer. In all cases, the manufacturer's QA inspection process failed to identify the cracks.	*DI21; VI23	O Dec-09	O		
367	Crossover joints should be used on riser strings of mixed manufacture. Verify that parts from the different manufacturers are not being mixed.	*VI03	O Dec-09	O		
368	Ensure that a sufficient supply of choke and kill packing is on board for 100% of the riser to be used in the well plus a 50% reserve of spare seals.	*WEST ITP #29, Riser - General; CAR 07-10	O Dec-09	O		
369	E.4.3.1: Vetco HMF Riser	*Vetco Gray PRP				
370	All subsea drilling equipment, including riser system components, should be washed down with fresh water after recovery from saltwater.	*Vetco Gray PRP	O Dec-09	O		
371	Verify proper torque for riser flange bolts is being applied. {Aug-05 Electronic monitoring system installed.}	*Vetco Gray PRP	O Dec-09	O		
372	Verify the auxiliary line pin stick-out dimensions are within Vetco's allowables. {Item not checked since before Apr-06.} {Aug-05 Although the riser is in good condition, there is a lot of room for improvement concerning documentation and tracking of the riser inspections. Documentation for the inspections completed in May 2003 could not be located to verify what was inspected as compared to the criteria in the 1825 PM procedure.} {Jun-09 Riser sent out to Expert Riser for major survey.}	*Vetco Gray Equipment Service Manual	O Dec-09	O		

ID	Assessment Point	Reference	Previous Status	Current Status	Inspection Method	Comments
373	Verify the auxiliary line float dimensions are within Vetco's allowables. <i>{Item not checked since before Apr-06.} {Aug-05 Although the riser is in good condition, there is a lot of room for improvement concerning documentation and tracking of the riser inspections. Documentation for the inspections completed in May 2003 could not be located to verify what was inspected as compared to the criteria in the 1825 PM procedure.}</i>	*Vetco Gray Equipment Service Manual	O Dec-09	O		
374	Remove pin and box protectors and check all sealing surfaces and seal grooves for signs of excess wear or damage. Repair as needed.	*Vetco Gray PRP	O Dec-09	O		
375	Verify all seals are in good condition or are newly installed.	*Vetco Gray PRP	O Dec-09	O		
376	If not replaced, inspect seals on pin and box connectors for cuts, cracks, loss of elasticity or change in hardness.	*WEST ITP #29, Riser - General	O Dec-09	O		
377	Verify the auxiliary lines are properly clamped and that the rubber isolator is in place between each clamp band and the pipe.	*Vetco Gray PRP	O Dec-09	O		
378	Verify spare parts for the riser joints include: 1 set static seals, 2 sets internal dynamic seals, 3 sets external seals, 3 sets special seals, 2 each socket head cap screws where less than 10 are used, 4 each socket head cap screws where more than 10 are used, and 1 each of any special component or sub-assembly that could cause downtime. <i>{Item not checked since before Apr-06.}</i>	*Vetco Gray PRP	O Dec-09	O		
379	Verify internal design modifications have been completed on the hydraulic handling tool. <i>{Item not checked since before Apr-06.}</i>	*Vetco Product Advisory #FSA H991062	O Dec-09	O		

ID	Assessment Point	Reference	Previous Status	Current Status	Inspection Method	Comments
380	A safety issue has recently been identified with some MR-6 and HMF telescopic joint latches. Two different designs of dog have been found in the same telescopic joint's hydraulic latch assembly. There is potential for the dogs to be overloaded if all eight dog assemblies are not identical. This problem has only been found in telescopic joints with the following part numbers: A20036-24, A20036-26, A20036-49, B128349-1, R10758-1 and R10788-1. Verify the correct dogs are installed in all telescopic joints, including spare joints, either through identification by part number or by measurement of critical dimensions. The correct assembly number is H10814-1.	*Vetco Product Advisory #FSA A070006	O Dec-09	O		
381	Verify that HMF riser has been inspected as required by Vetco Product Alert #FSA HO 32482, Rev. A.	*Vetco Product Alert #FSA HO32324	O Dec-09	O		
382	E.4.3.1.1: Vetco SLS Tension Ring	Vetco Gray Procedures				
383	Verify the recommended lubricants for the SLS tension ring are available and used. General use is Jet Lube Alco EP-73-; threads is Never Szez or equivalent; and bearing fluid is control system operating fluid.	*Vetco Gray Procedures	O Dec-09	N/A		The rig has an SDC (Split Direct Cylinder) ring.
384	Verify the manual locking bolts are installed in the locking dogs while in the stowed position. Ensure the correct length bolts are installed. Longer bolts are required for the dogs that lock to the slip joint.		O Dec-09	N/A		
385	Verify testing and use comply with the SLS tension ring ratings: normal operating pressure of locking dogs, 1,500 psi; maximum operating pressure of locking dogs, 3,000 psi; and maximum pressure for fluid bearing, 3,000 psi.	*Vetco Gray Procedures	O Dec-09	N/A		
386	Visually observe proper extension/retraction of the riser support dogs. Operation should be smooth; repair as needed.	*Vetco Gray Procedures	O Dec-09	N/A		

ID	Assessment Point	Reference	Previous Status	Current Status	Inspection Method	Comments
387	Ensure that fluid bearing cavity is properly filled with fluid: hydraulic line to have not return valve, remove bleed plug, fill cavity and expel air, replace plug, pressurize to 20 to 30 psi.	*Vetco Gray Procedures	O Dec-09	N/A		
388	Verify spare parts for the SLS tension ring include: 1 set static seals, 2 sets dynamic seals, 3 sets external seals, 3 sets special seals, full set of socket set screws, 2 each socket head cap screws where less than 10 are used, 4 each socket head cap screws where more than 10 are used, hose/fittings as needed, and 1 each of any special component or sub-assembly that could cause <i>deviations</i> .	*Vetco Gray Procedures	O Dec-09	N/A		
389	E.4.4: Auxiliary Lines					
390	To avoid the potential for plugged auxiliary lines, verify that the I.D. of the auxiliary lines are cleaned thoroughly on those riser joints that have been out of service for more than one well. <i>{Item has not been checked since before Aug-05.}</i>	*CAR 03-02	O Dec-09	O		
391	To prevent accidental mismatching of the choke and kill and auxiliary lines when the riser is deployed, verify that the coupling is oriented asymmetrically around the riser support ring.	*API Spec 16Q, 1st Edition, Section 2.12.3.e	O Dec-09	C V		
392	Choke and kill pins should be visually inspected. An acceptable surface finish is 32 RMS or better.	*API Spec 16Q, 1st Edition, Section 4.2.a	O Dec-09	O		
393	E.4.5: Flex Joint, Keyseating and Rig Positioning Equipment (Flex Joint and Ball Joint)					
394	Check throughbores flex joint, LMRP and BOP stack for keyseating and document any defects found.	*WEST ITP #42, Allowable BOP Vertical BORE Keyseating	O Dec-09	C	V	Slight keyseating was observed in the riser adapter. The subsea engineer will monitor the keyseating. DM May-10

ID	Assessment Point	Reference	Previous Status	Current Status	Inspection Method	Comments
395	Verify bulls-eyes are on adjustable mounts to allow for leveling. Verify bulls-eyes are "zeroed" prior to running the stack.	*API Spec 16Q, 1st Edition, Section 4.4.2	O Dec-09	C	I	
396	Verify that the marine riser system is suitably instrumented and monitored to ensure safe and reliable performance.	*API Spec 16Q, 1st Edition, Section 4.4.2	O Dec-09	O		
397	Verify bulls-eyes and other positioning systems are calibrated. Contractor should provide a procedure.	*API Spec 16Q, 1st Edition, Section 4.4.2	O Dec-09	O		
398	Section E.5: Mud Flow Network					
399	E.5.1: Choke and Kill Manifold	*CHOKEMANIFOLD HISTORY				
400	Verify the rig's drawings of the manifold are correct.	Choke Manifold Drawing.doc	O Dec-09	O		
401	Chokes that do not pressure test or at least hold back-pressure should be disassembled for visual inspection and repair. Chokes are not required to seal full pressure, but failure to hold test or at least hold back-pressure is an indication of a serious internal problem. Pump through the chokes and check they are regulating at various values. <i>{Mar-07 Item not checked.} {Aug-05 The choke manifold is in good operating condition although preventive maintenance is limited to lubrication. The condition of the chokes is unknown and can best be determined by disassembly and inspection.}</i>		O Dec-09	O		
402	The pump system shall have a storage reservoir with a volume at least ten times the capacity of the hydraulic drilling choke control system, excluding the reservoir. The reservoir volume need not exceed 10 gallons. <i>{Item not checked since before Apr-06.}</i>	*API Spec 16C, 1st Edition, Section 9.16.1	O Dec-09	O		
403	If equipped with accumulators, the pump volumetric capacity shall be sufficient to close the choke within 20 seconds. <i>{Item not checked since before Apr-05.}</i>	*API Spec 16C, 1st Edition, Sections 9.16.2 and 9.16.3	O Dec-09	O		

WEST ©

ID	Assessment Point	Reference	Previous Status	Current Status	Inspection Method	Comments
404	With accumulators isolated, the pump volumetric capacity shall be sufficient to close the choke within 30 seconds.	*API Spec 16C, 1st Edition, Sections 9.16.2 and 9.16.3	O Dec-09	O		
405	The remote choke accumulator volumetric capacity, if equipped, shall be able to operate the choke from fully-open to fully-closed and return to fully-open.	*API Spec 16C, 1st Edition, Section 9.16.6	O Dec-09	O		
406	Verify choke and kill manifold valves can be tested from the correct direction. The first valve on the manifold, coming from the choke and kill lines, should be tested from the wellbore side. Visual inspection of chokes and targets shall be prior to pressure testing. <i>{Apr-06 2 choke valves leaked during pressure test. Replaced gates and seats. Valve #10 had corrosion into sealing areas. WOM service hands recommended change out when rig activities allow, as well as WEST.}</i>		O Dec-09	O		
407	Verify that the remote choke actuation backup system is operating correctly. There shall be a backup operating system to open or close the drilling choke when there is a loss a primary power. The rated working pressure of the backup system shall be equal to or greater than the primary hydraulic pump. Function test the system.	*API Spec 16C, 1st Edition, Section 9.16.7; API RP 53, 3rd Edition, Section 9.2.1.K	O Dec-09	O		
408	Verify there is an operating manual from the manufacturers of the remote choke systems and chokes available for each model installed. This manual should include: operation and installation instructions, physical data, seals information, maintenance and testing information, disassembly and assembly information, parts information and storage information. Review wellbore wetted choke parts and comment.	*API Spec 16C, 1st Edition, Section 9.17	O Dec-09	O		
409	E.5.2: Diverter	*DIVERTEHISTORY				
410	Record the following:		O Dec-09	O		Due to time constraints the diverter was not inspected.

ID	Assessment Point	Reference	Previous Status	Current Status	Inspection Method	Comments
411	a. part number {Mar-07 P/N 157206}	157206	O Dec-09	O		
412	b. serial number {Mar-07 S/N 7868-02-07}	7868-02-07	O Dec-09	O		
413	c. date of manufacture {Mar-07 - Feb-07.}	Mar-07	O Dec-09	O		
414	d. elastomer type {Mar-07 Nitrile.}	Nitrile	O Dec-09	O		
415	e. date in service {Mar-07 - 21-Mar-07.}	Mar-07	O Dec-09	O		
416	f. number of cycles {Mar-07 Zero.}		O Dec-09	O		
417	Vent lines should be 10" ID offshore, 6" or larger for onshore.		O Dec-09	O		
418	The diverter valves should be sequenced such that the vent line valve is fully open prior to closure of the sealing element. Function test the diverter system interlocks preventing the wellbore from being closed in.		O Dec-09	O		
419	Verify that actuators fitted to diverter valves are sized to open the valve with the rated working pressure of the diverter system applied across the valve.		O Dec-09	O		
420	Verify flow line seals and packer is in good condition. {Mar-07 Flow line seal is in good condition. New packer installed 21-Mar-07.}		O Dec-09	O		
421	Function test the diverter system interlocks preventing the wellbore from being closed in. The control system should be selectively sequenced, so when the diverter is closed, the shaker valve closes and overboard valve(s) open.	*API RP 53, 3rd Edition, Section 5.2.3	O Dec-09	O		
422	Verify diverter valves used in the diverter vent line(s) or in the flow line to the shale shaker are full-opening, have at least the same opening as the line in which they are installed.	*API RP 64, 2nd Edition, Section 5.6.1 and 5.6.2	O Dec-09	O		

ID	Assessment Point	Reference	Previous Status	Current Status	Inspection Method	Comments
423	Verify that the primary diverter closing system is capable of operating the vent line and flow line valves and closing the annular packing element on pipe in use or open hole within 30 seconds of actuation, if the packing element has a nominal bore of 20" or less. For elements of more than 20" nominal bore, the diverter control system should be capable of operating the vent line and flow line valve and closing on pipe in use within 45 seconds.	*API Spec 16D, 2nd Edition, Section 5.5.2; API RP 64, 2nd Edition, Section 5.8.2	O Dec-09	O		
424	Verify the pump system(s) is capable of recharging the primary diverter control system accumulators to full system design pressure within five minutes or less, after one complete diverter mode operation of the diverter control system.	*API Spec 16D, 2nd Edition, Section 5.5.4	O Dec-09	O		
425	Verify the diverter control system has sufficient accumulator capacity to provide the usable hydraulic fluid volume (with pumps inoperative) required to operate all of the divert mode functions plus 50% reserve.	*API RP 64, 2nd Edition, Section 5.8.1	O Dec-09	O		
426	Verify an alternate means is employed to permit sequencing the diverter system should the primary closing system become inoperative. Examples include a separate pump system or separate isolated accumulator capacity.	*API Spec 16D, 2nd Edition, Section 5.5.5	O Dec-09	O		
427	Verify diverter system is equipped with remote-controlled valves in the flow and vent lines that can be operated from at least one remote-control station in addition to the one on the drill floor.	*API RP 64, 2nd Edition, Section 5.8 *MMS CFR Title 30, Chapter II, Section 250.431, Paragraph c	O Dec-09	O		
428	Verify no manual or butterfly valve is installed in any part of the diverter system.	*MMS CFR Title 30, Chapter II, Section 250.431, Paragraph (d)	O Dec-09	O		

ID	Assessment Point	Reference	Previous Status	Current Status	Inspection Method	Comments
429	Verify all right-angle and sharp turns are targeted.	*MMS CFR Title 30, Chapter II, Section 250.431, Paragraph (e) *API RP 64, 2nd Edition, Section 5.7.2	O Dec-09	O		
430	Verify the entire diverter system is firmly anchored and supported to prevent whipping and vibration.	*MMS CFR Title 30, Chapter II, Section 250.431, Paragraph (f) *API RP 64, 2nd Edition, Section 5.7.3	O Dec-09	O		
431	If diverter system operating pressure can be increased above the maximum recommended diverter operating pressure, a relief valve should be installed to protect the diverter. <i>{Mar-07 New 3,300 psi relief valve was installed.}</i>	*API Spec 16D, 2nd Edition, Section 5.5.6	O Dec-09	O		
432	If applicable, the diverter system should have an interlock system to prevent insert packer closure unless the insert packer is installed and the insert packer lock-down dogs are energized.	*API Spec 16D, 2nd Edition, Section 5.5.6	O Dec-09	O		
433	Ensure all diverter system components have a rated working pressure of at least 200 psi.	*API RP 64, 2nd Edition, Section 5.1	O Dec-09	O		
434	The diverter control system shall be operated such that the well will not be shut in with the diverter system. At least one vent valve should remain open at all times to prevent a complete shut-in of the well if there is a partial failure of the control system and/or vent controls.	*API RP 64, 2nd Edition, Section 5.9	O Dec-09	O		
435	Some diverter systems have a "test mode" used primarily for testing the diverter system. If left in the test mode, the diverter system will not function as required in a well control situation. Verify there is a written policy or procedure in place that will prevent improper operation of the control system. Also, verify that up-to-date manuals are available. <i>{Item not checked since before Aug-05.}</i>	*IADC Safety Alert 03-43; API RP 53, 3rd Edition, Sections 18.4.2.c and 18.11.1	O Dec-09	O		

ID	Assessment Point	Reference	Previous Status	Current Status	Inspection Method	Comments
436	An air storage or nitrogen backup system shall be provided with the capability to operate all of the pneumatic functions at least twice in the event of loss of rig air pressure.	*API Spec 16D, 2nd Edition, Section 5.5.6	O Dec-09	O		
437	E.5.2.1: Vetco KFDS - CSO Diverter					
438	Verify the recommended lubricants for the Type KFDS diverter are available and used: operating fluid should be Houghton Safe 273 or equivalent; seals and sealing surfaces, medium weight high grade machine oil; fasteners/threads, Never-Seez or equivalent; spherical surface on ID of diverter head, Moly lube or equivalent.	*Vetco Gray Equipment Service Manual	O Dec-09	O		
439	Verify testing and use comply with the Type KFDS diverter ratings: Pressure rating, up to the rating of the diverter support housing (500 psi) but not to exceed 1,000 psi on 5" pipe or 500 psi on open hole; Diverter operating pressure, 1,500 psi; Tensile rating, up to 2 million pounds; Operating pressures in psi for various casing sizes are 7" - 1200, 7-5/8" - 1100, 8-5/8" - 1000, 9-5/8" - 900, 10-3/4" - 800, 11-3/4" - 650, 13-3/8" - 500; Open/close lines are to be 1-1/2" hose, volume to open is 15 gallons and to close is 31 gallons; Closure range is 21-1/4" (full bore) to open hole. <i>{Item not checked since before Apr-96.}</i>	*Vetco Gray Equipment Service Manual	O Dec-09	O		
440	Verify diverter is locked in the housing with 1,500 psi applied to the locking dogs. This pressure is to be maintained at all times during operation.	*Vetco Gray Equipment Service Manual	O Dec-09	O		
441	Closing pressure for drill pipe or collars 8" and smaller should be 1,500 psi. Casing requires lower pressures; verify chart of required pressures is available. As soon as casing has passed through the diverter, the pressure should be set back to 1,500 psi.	*Vetco Gray Equipment Service Manual	O Dec-09	O		

ID	Assessment Point	Reference	Previous Status	Current Status	Inspection Method	Comments
442	Verify flow line seals are energized with 250 to 350 psi. During operation, energize pressure up to 750 psi may be required to maintain seal integrity. If the energizing pressure of 250 to 350 psi is locked in by the control system, no regulation of the pressure is necessary.	*Vetco Gray Equipment Service Manual	O Dec-09	O		
443	Operating system pressure test: Apply 500 psi to open port and check for leaks. Repair if necessary, increase pressure to 1,500 psi in 500 psi increments, hold for 5 minutes. Acceptance is no leaks. Apply 500 psi to the close port and check for leaks. Repair if necessary. Increase the pressure to 1,500 psi in 500 psi increments, hold for 15 minutes. Acceptance is no leaks.	*Vetco Gray Equipment Service Manual	O Dec-09	O		
444	Verify spare parts for the CSO diverter include: 1 set static seals, 2 sets dynamic seals, 3 sets external seals, 3 sets special seals, full set of socket set screws, 2 each socket head cap screws where less than 10 are used, 4 each socket head cap screws where more than 10 are used, hose/fittings as needed, and 1 each of any special component or sub-assembly that could cause downtime. <i>{Item not checked since before Aug-05.}</i>	*Vetco Gray Equipment Service Manual	O Dec-09	O		
445	Verify the design of the split retainer ring on the flow line seals has been revised to incorporate the latest design changes. The new part number is A20043-228.	*Vetco Product Announcement #VD 01	O Dec-09	O		
446	E.5.3: Mud-Gas Separator					
447	Record location and pressure setting of alarms on the degasser. Function test all. <i>{Item not checked since before Aug-05.} {Jun-09 New system to send mud to the poorboy from the diverter just installed. Cameron will provide software and setup in near future. Not operational as of this date even though fabrication is complete.}</i>		O Dec-09	O		

ID	Assessment Point	Reference	Previous Status	Current Status	Inspection Method	Comments
448	Record location and span of pressure gauges on the poorboy degasser. Comment on the communication between the poorboy degasser pressures and the driller. Is there a remote readout? <i>{Item not checked since before Aug-05.}</i>		O Dec-09	O		
449	Review and record rig procedures to bypass the poorboy degassers and vent fluids if pressures rise to an unacceptable level. Record pressure at which this occurs. <i>{Item not checked since before Aug-05.} {Jun-09 New procedure will be completed after software is installed and system is commissioned.}</i>	*API RP 53, 3rd Edition, Section 15.9	O Dec-09	O		
450	Check mud-gas separator interior and vent lines for erosion and obstructions. <i>{Item not checked since before Aug-05.}</i>	*API RP 53, 3rd Edition, Section 15.9	O Dec-09	O		
451	Record and comment on the design of the mud-gas separator. Identify liquid level and vent line size and length. <i>{Item not checked since before Aug-05.}</i>	*WEST ITP #79, Mud Gas Separator; "Well Control When Drilling With Oil-Based Mud" by Turner, E.B; API RP 53, 3rd Edition, Section 15.9	O Dec-09	O		
452	Provide a sketch of the mud-gas separator. <i>{Item not checked since before Aug-05.}</i>		O Dec-09	O		
453	Verify an access port is available for internal inspection of the degasser. After proper safety precautions are completed, internally examine the degasser. <i>{Item not checked since before Aug-05.}</i>	*WEST ITP #79, Mud Gas Separator; "Well Control When Drilling With Oil-Based Mud" by Turner, E.B; API RP 53, 3rd Edition, Section 15.9;	O Dec-09	O		
454	E.5.4: Kelly Cocks, Safety Valves and High-pressure Piping					
455	Verify the lower kelly valves, kelly, kelly cock, drill pipe safety valves, inside BOPs and top drive safety valves are tested with water pressure applied from below to a low-pressure of 200 to 300 psi then to the rated working pressure.	*API RP 53, 3rd Edition, Section 18.3.2.2	O Dec-09	O		Due to time constraints the HP piping was not inspected.

ID	Assessment Point	Reference	Previous Status	Current Status	Inspection Method	Comments
456	Visually inspect the high-pressure pipe work on the rig and note its condition. Note that piping out of sight or hidden by bulkheads is especially susceptible to corrosion. Record the date of the last wall thickness major survey.	*API RP 53, 3rd Edition, Section 18.10.3; WEST ITP #7, Determination of Pipe Wall Thickness and Working Pressure by Ultrasonic Testing	O Dec-09	O		
457	If piping system is over five years old, provide copies of minimum wall thickness calculations with report. State if not available. <i>{Item not checked since before Aug-05.}</i>	*API RP 53, 3rd Edition, Section 18.10.3; WEST ITP #7, Determination of Pipe Wall Thickness and Working Pressure by Ultrasonic Testing	O Dec-09	O		
458	Section E.6: Motion Compensation System	*MOTION COMPENSATION HISTORY				
459	E.6.1: Riser Tensioners					
460	Verify pressure vessels and pressure relieving devices are in compliance with acceptable inspection frequencies. <i>{Item not checked since before Apr-06.}</i>	*WEST ITP #60, Pressure Vessels & Pressure Relieving Devices	O Dec-09	O		Due to time constraints the riser tensioners were not inspected.
461	Extend tensioners and pressure to maximum working pressure and verify there are no leaks. While extended, inspect surface finish of rods for defects. <i>{Item not checked since before Apr-06.}</i>	*API Spec 16Q, 1st Edition, Section 4.6.1	O Dec-09	O		
462	Verify fluid levels and proper lubrication per manufacturer. <i>{Item not checked since before Apr-06.}</i>	*API Spec 16Q, 1st Edition, Section 4.6.1	O Dec-09	O		
463	Review the riser tension program used for this location and comment. Consider the case where tensioners are down to cut and slip. <i>{Item not checked since before Aug-05.}</i>	*API RP 16Q, 1st Edition, Section 2.4.3.f	O Dec-09	O		

ID	Assessment Point	Reference	Previous Status	Current Status	Inspection Method	Comments
464	Verify that information regarding the amount of riser tension required for various mud weights is available on the rig. Posting of this information in an easily readable format would be beneficial. <i>{Item not checked since before Apr-06.}</i>	*API RP 16Q, 1st Edition, Section 3.2.4	O Dec-09	O		
465	Verify the Effective Riser Tension is defined and added to riser tension calculations. <i>{Item not checked since before Aug-05.}</i>	*WEST ITP #66, Riser Tensioner Efficiency Calculations	O Dec-09	O		
466	E.6.2: High-pressure Air System (Compressor, Piping/Valves, and APVs)					
467	Verify grounding terminals (or some other means) are utilized on the APVs and high-pressure piping if they are insulated by use of plastic clamps or rubber gaskets. <i>{Mar-07 Rig uses high pressure nitrogen instead of air.}</i>	*WEST Safety Memo #1	O Dec-09	O		
468	Review the HP (high-pressure) air compressor installation and comment. If rig air is used to supply the HP compressors, document the type of oil used in the rig air compressors. Are filters used to exclude petroleum based lubricants from the HP compressor supply?	*WEST Safety Memo #1	O Dec-09	O		
469	If the system allows for the possible introduction of petroleum based lubricants, ensure a system is in place to periodically monitor the condensate for contamination. Condensate samples can be obtained at the IIP compressor final stage or IIP air dryer.		O Dec-09	O		
470	Verify the drain/bleed valve on the APVs are at the lowest possible point. This is especially critical on APVs mounted vertically.		O Dec-09	O		
471	Verify pressure relief valve discharges are located and anchored to prevent a hazardous condition due to a sudden discharge or piping movement.	*API RP 54, 3rd Edition, Section 9.13.2	O Dec-09	O		

ID	Assessment Point	Reference	Previous Status	Current Status	Inspection Method	Comments
472	Ensure the APV vessels are rated at the same or higher pressure rating as the motion compensator.		O Dec-09	O		
473	E.6.3: Drill String Compensator					
474	E.6.3.1: Shaffer Chain Type Drill String Compensator					
475	Extend the compensator and increase the pressure to maximum working pressure. Check for leaks.		O Dec-09	N/A		
476	Function test the control panel. This includes mechanical locking in the collapsed position.		O Dec-09	N/A		
477	Check chain for excessive stretch.		O Dec-09	N/A		
478	Review planned maintenance procedures.		O Dec-09	N/A		
479	Section E.7: Well Control Equipment Testing					
480	E.7.1: Wellbore Pressure Testing					
481	Initial stump tests on rams, annulars and valves will be to low-pressure (200 to 300 psi) and maximum working pressure. Test durations are 5 minutes for low-pressure testing and 10 minutes for high-pressure testing. All low-pressure testing will be conducted prior to high-pressure testing. Do not go to a higher pressure and bleed down to the low pressure. The drilling program should be consulted and used if any conflicts in testing procedure exist. Annulars may be tested to 70% of working pressure. <i>{Apr-06 5 min/5 min} {Sep-09 Tested to 250/1,1500 psi 5/5 mins.}</i>	*API RP 53, 3rd Edition, Sections 18.3.2.1 and 18.3.2.2; WEST ITP #11, General Pressure Testing Requirements	C Dec-09	C	T	Rams and failsafe valves were pressure tested 200-300 psi for 5 minutes and 15,000 psi for 5 minutes. Annular was pressure tested to 200-300 psi for 5 minutes and 10,000 psi for 5 minutes.
482	Verify that wellbore pressure test records are witnessed, dated and signed.	*API Spec 16A, 3rd Edition, Section 8.5.8.5	C Dec-09	C	V, T, D	

ID	Assessment Point	Reference	Previous Status	Current Status	Inspection Method	Comments
483	Verify rig has an approved procedure for recording wellbore and function tests. All test results should be recorded in Tables III and IV.	*API RP 53, 3rd Edition, Section 18.5	C Dec-09	C	D	
484	Verify that VBRs (variable bore rams) are tested on all sizes of pipe that will be used on the well (excluding drill collars and bottom hole tools). This is recommended that testing be done on the stump prior to drilling operations.	*MMS CFR Title 30, Chapter II, Section 250.449, Paragraph (f) *API Spec 16A, 3rd Edition, Section 8.5.8.7.3; API RP 53, 3rd Edition, Section 18.5.5	C Dec-09	C	T	The HVR's were pressure tested using a 5" and 6-5/8" test joint.
485	Annulars should be wellbore pressure tested against the smallest pipe to be used in the drilling program. {Apr-06 6-5/8", 5" and 9-5/8".}	*API RP 53, 3rd Edition, Section 18.5.3	C Dec-09	C	T	The annular was pressure tested using a 5" and 6-5/8" test joint.
486	Visually check weep holes or bleeder valves for leakage during wellbore and operating chamber pressure testing of BOP.	*MMS CFR Title 30, Chapter II, Section 250.446, Paragraph (a) *API RP 53, 3rd Edition, Section 18.10.1; WEST ITP #16, Ram Preventers - General	C Dec-09	C	V, T	
487	Verify that no solid plugs are installed in the weep holes.	*MMS CFR Title 30, Chapter II, Section 250.446, Paragraph (a) *API RP 53, 3rd Edition, Section 18.10.1; WEST ITP #16, Ram Preventers - General	C Dec-09	C	V	

ID	Assessment Point	Reference	Previous Status	Current Status	Inspection Method	Comments
488	For ram preventers, verify that there is no sealant in place and that the secondary packing has not been energized. Check injection port to ensure it is free of sealant.	*MMS CFR Title 30, Chapter II, Section 250.446, Paragraph (a) *API RP 53, 3rd Edition, Section 18.10.1; WEST ITP #16, Ram Preventers - General	O Dec-09	O		
489	Add Fluorescein dye or similar color tracer prior to wellbore testing.		O Dec-09	O		
490	E.7.2: Hydraulic Operating Chamber Testing, BOP Testing Pump					
491	Verify if uncharted operating chamber tests are performed between wells. This can be accomplished by increasing manifold pressure and observing the chambers for a specified period.	*API RP 53, 3rd Edition, Section 18.2.4	C Dec-09	O		
492	Verify a charted pressure test has been performed on operating chambers to maximum working pressure with the possible exception of annular close. The acceptance criteria for pressure testing operating chambers and wellbore shall be no leaks and test duration should be 5 minutes. Formal, charted tests should be performed every 6 to 12 months, depending on rig policy.	*API RP 53, 3rd Edition, Sections 18.2.4 and 18.3.2.4; IADC Deepwater Well Control Guidelines, Section 3.7.2.1; WEST ITP #11, General Pressure Testing Requirements	C Dec-09	O		The LOK, wellhead connector and forward casing shear ram operator was tested during this survey.
493	All charted operating chamber tests results should be recorded in Table V. <i>{Mar-07 Tested the Annuflex and diverter operators.</i>	*API RP 53, 3rd Edition, Sections 18.2.4 and 18.3.2.4; IADC Deepwater Well Control Guidelines, Section 3.7.2.1; WEST ITP #11, General Pressure Testing Requirements	C Dec-09	O		The casing shear ram bonnets operating chambers were pressure tested to 4,000 psi. The forward bonnet was rebuilt during this survey due to leaks. The bonnet was replaced with a rebuilt bonnet. DM May-10

ID	Assessment Point	Reference	Previous Status	Current Status	Inspection Method	Comments
494	E.7.3: Rams					
495	Rams will be wellbore pressure tested with the locking system engaged and the operating pressures on the ram vented to zero. In the case of variable bore rams, this procedure to be followed on all size pipe tested. <i>{Dec-09 Not tested on locks; discussed with BP co. rep. prior to stump test.}</i>	*API RP 53, 3rd Edition, Section 18.5.9	/ Dec-09	C		
496	E.7.4: Annulars					
497	The annular element shall be visually inspected and shall be in good condition.	*API Spec 16A, 3rd Edition, Section 8.5.8.4; IADC Deepwater Well Control Guidelines, p. 3-27, Section 3.7.2.2; WEST ITP #12, Annular Preventer - General; CA06	C Dec-09	C	V	The annular element was visually inspected using the WESTscope camera. The video was given to the subsea engineer. DM-May-10
498	Visually check annular weepholes for leakage during wellbore testing.		C Dec-09	C	V, T	
499	E.7.5: Connectors (LMRP and Wellhead)					
500	Unloaded backdriving test: As a minimum, lock both connectors with 1,500 psi and vent the locking pressure. Record any movement of the indicator rod. Wellhead connector: LMRP connector: <i>{Apr-06 Completed on LMRP, .225" movement. Vetco called confirmed...}</i>	*WEST ITP #39, Backdriving - Hydraulic Connectors	O Dec-09	O		

ID	Assessment Point	Reference	Previous Status	Current Status	Inspection Method	Comments
501	Function test LMRP, wellhead and choke and kill line connectors. Record the unlocking pressure requirements and verify to manufacturers allowable. Rig owner is to verify this acceptance criteria as in PM system.	*API RP 53, 3rd Edition, Section 18.2.4	O Dec-09	C	T, V	Function test LMRP, wellhead and choke and kill line hydraulic stabs.
502	Pressure test the POCV circuit, if so equipped.		N/A Dec-09	N/A		
503	E.7.6: Stack Valves and Lines					
504	Function test all failsafe valves verifying correct position. Verify spring returns the gate to the closed position prior to wellbore tests. Do not use operating pressure to close valves.	*MMS CFR 30 section 250.446 (a) *API RP 53, 3rd Edition, Section 18.2.4	C Dec-09	/	T	The lower outer kill would not fully close on spring tension alone. The operator was replaced with a rebuilt operator.
505	The choke and kill valves will be tested from the top in addition to wellbore testing. State if accomplished prior to running stack. Is this an existing rig procedure?		C Dec-09	C	T	All failsafe valves were pressure tested from the topside also.
506	E.7.7: Function Testing					
507	Review the rig's function test procedure. Ensure a policy is in place requiring that a competent person visually verify each function. This person should always be positioned close enough to the equipment to easily verify proper functioning or use sight aids (binoculars or equivalent).	*API RP 53, 3rd Edition, Section 18.3.1	C Dec-09	C	T, V	
508	Function test the shearing blind rams before pipe is installed in the bore. With pipe installed in the bore, close pipe rams and annulars with 1,500 psi starting from the bottom of the BOP and visually check down the bore to verify the correct rams function. Check all hoses, connections and pod valves for leaks. Do not close shear rams with pipe in the bore.	*API RP 53, 3rd Edition, Section 18.3.1	C Dec-09	C	T	
509	If failsafe valves are not equipped with indicator/tail rods, valve position should be verified by filling the kill and choke lines with water and opening the valves one at a time, observing where the water exits inside the stack bore.		C Dec-09	O		Failsafe valves equipped with indicator rods.

ID	Assessment Point	Reference	Previous Status	Current Status	Inspection Method	Comments
510	E.7.8: Accumulator Unit					
511	Perform the accumulator volume test per API RP 53. After opening and closing all rams and one annular BOP, the remaining accumulator pressure shall be 1,200 psi for 3,000 psi systems and 1,700 psi for 5,000 psi systems. Accumulator system must meet this requirement without any pump assistance. <i>{Item not checked since before Aug-05.}</i>	*MMS CFR Title 30, Chapter II, Section 250.442, Paragraph (c), *API RP 53, 3rd Edition, Section 13.3.2	O Dec-09	O		
512	Verify that a backup to the primary accumulator-charging system is automatic, supplied by a power source independent from the power source to the primary accumulator-charging system, and possesses sufficient capability to close all BOP components and hold them closed.	*MMS CFR Title 30, Chapter II, Section 250.443, Paragraph (a)	O Dec-09	O		
513	Record the pump up time to maximum working pressure of control system after volume test. Maximum allowable is 15 minutes. Minutes: _____ Seconds: _____ <i>{Item not checked since before Aug-05.}</i>	*API RP 53, 3rd Edition, Sections 13.4.1 or 14.3.1	O Dec-09	O		
514	E.7.9: Pods					
515	Ensure all packer seals are in new condition and retainers are tight.	*API RP 53, 3rd Edition, Section 19.10	O Dec-09	C	V	Several pod packer seals were replaced during this survey.
516	Verify an equipment specific function test procedure that includes all operable functions is available and used.	*API RP 53, 3rd Edition, Section 18.3.1	C Dec-09	C	D	
517	Function test the stack with each pod, recording times and volumes.	*API RP 53, 3rd Edition, Section 18.3.1	C Dec-09	C	T	
518	Prior to running the stack, pressure test all functions, open and close, from both pods for 30 minutes at maximum operating pressure. Blue Yellow	*API RP 53, 3rd Edition, Section 13.9.1	C Dec-09	O		The stack was not run.

ID	Assessment Point	Reference	Previous Status	Current Status	Inspection Method	Comments
519	E.7.10: Secondary Intervention, Emergency Acoustic Control					
520	The hot stabs must be tested during the stump test to ensure no operability problems exist. <i>{Apr-06 Upper, lower and casing shear rams functioned. In Feb-06 the LMRP connector used to unlatch LMRP subsea.}</i>	*API RP 53, 3rd Edition, Section 18.3.1; WEST ITP #169, Secondary Intervention; MMS NTL	C Dec-09	/	I	The hot stabs were in the process of being tested when WEST departed the rig.
521	Wellbore pressure test each component as applicable after the secondary system has been activated. This is especially critical concerning the shear rams and will prove the secondary system is capable of securing the well. <i>{Mar-07 All ROV stabs were function tested.} {Apr-06 Shear rams were function tested using hot stab. MPL locks were tested per EB 05-609 separately and during wellbore pressure test with control system.}</i>		O Dec-09	/	I	
522	Section E.8: HPHT and Sour Gas Considerations					
523	Verify the maximum acceptable hardness for all preventer and valve bodies and spools in H2S service is in accordance with NACE Standard MR0175 (22 RC or 237 BHN). Note: If sour gas is expected, also check repairs are in compliance with NACE as well as internal wellbore wetted parts.	*API RP 53, 3rd Edition, Section 20.2.3	O Dec-09	O		
524	Verify wellbore wetted components suitable for use in H2S service (if required).	*WEST ITP #49, H2S Service; API RP 53, 3rd Edition, Section 20	O Dec-09	O		
525	Verify material selection for choke and kill lines meets NACE MR0175 for H2S Service (as required).	*API Spec 16Q, 1st Edition, Section 2.12.3.g	O Dec-09	O		
526	Glycol injection on choke and kill manifold. Record injection rate, location of injection and equipment used to inject the glycol. Verify if all chokes will be fed with glycol.		O Dec-09	O		

Table III – Wellbore Pressure Testing

Check high pressure auxiliary line hoses for current inspection certificates, including full internal and external inspections, as per original equipment manufacturer's specifications. Record this and serial number, dates of manufacture and last survey in the table below. The certificates should be on the rig or readily available. Reference API RP 53 Sections 18.10.3 and 18.13.2, and MMS Title 30 Chapter II, Section 250.446, Paragraph (a). Manufacturer recommended testing intervals can be found in WEST ITP #56.

Item	Pipe Size(s)	Low Pressure Test		High Pressure Test		Comments
		Pressure	Time	Pressure	Time	
Lower pipe rams	9-5/8"	250 psi	5 min.	15,000 psi	5 min.	Good test.
Middle pipe rams	5" & 6-5/8"	250 psi	5 min.	15,000 psi	5 min.	Good test.
Upper pipe rams	5" & 6-5/8"	250 psi	5 min.	15,000 psi	5 min.	Good test.
Lower shear rams		250 psi	5 min.	15,000 psi	5 min.	Good test.
Upper shear rams		250 psi	5 min.	15,000 psi	5 min.	Good test.
Upper Annular	5" & 6-5/8"	250 psi	5 min.	10,000 psi	5 min.	Good test.
Lower inner choke		250 psi	5 min.	15,000 psi	5 min.	Good test.
Lower outer choke		250 psi	5 min.	15,000 psi	5 min.	Good test.
Upper inner choke		250 psi	5 min.	15,000 psi	5 min.	Good test.
Upper outer choke		250 psi	5 min.	15,000 psi	5 min.	Good test.
Lower inner kill		250 psi	5 min.	15,000 psi	5 min.	Good test.
Lower outer kill		250 psi	5 min.	15,000 psi	5 min.	Good test.
Upper inner kill		250 psi	5 min.	15,000 psi	5 min.	Good test.
Upper outer kill		250 psi	5 min.	15,000 psi	5 min.	Good test.
Upper inner annular bleed valve		250 psi	5 min.	15,000 psi	5 min.	Good test.
Upper outer annular bleed valve		250 psi	5 min.	15,000 psi	5 min.	Good test.
Choke isolation valve. This test ensures the pressure integrity of the Choke connection.		250 psi	5 min.	10,000 psi	5 min.	Good test.
Kill isolation valve. This test ensures the pressure integrity of the Kill connection.		250 psi	5 min.	10,000 psi	5 min.	Good test.

**Table IV – Pressure Testing
Kill & Choke Valves from the Top**

Note: Testing from the top also ensures the pressure integrity of the choke and kill connections between the LMRP and the lower BOP. If testing from the top is not conducted, the pressure integrity of the choke and kill connections may be verified by testing against the choke and kill isolation valves from the wellbore.

Item	Low Pressure Test		High Pressure Test		Comments
	Pressure	Time	Pressure	Time	
Lower inner kill	250 psi	5 min.	15,000 psi	5 min.	Good test.
Lower outer kill	250 psi	5 min.	15,000 psi	5 min.	Good test.
Upper inner kill	250 psi	5 min.	15,000 psi	5 min.	Good test.
Upper outer kill	250 psi	5 min.	15,000 psi	5 min.	Good test.
Lower inner choke	250 psi	5 min.	15,000 psi	5 min.	Good test.
Lower outer choke	250 psi	5 min.	15,000 psi	5 min.	Good test.
Upper inner choke	250 psi	5 min.	15,000 psi	5 min.	Good test.
Upper outer choke	250 psi	5 min.	15,000 psi	5 min.	Good test.
Choke isolation valve	250 psi	5 min.	15,000 psi	5 min.	Good test.
Kill isolation valve	250 psi	5 min.	15,000 psi	5 min.	Good test.
Mud boost valve	250 psi	5 min.	10,000 psi	5 min.	Good test.

Table V – Hydraulic Operating Chamber Pressure Testing

(Charted Tests Only)

Item	Open/Unlock Chamber		Close/Lock Chamber		Comments
	Pressure	Time	Pressure	Time	
Wellhead connector Primary	3,000 psi	5 mins	3,000 psi	5 mins	Tests done. May-10
Wellhead connector Secondary	3,000 psi	5 mins			Tests done. Jun-09
Lower pipe rams	3,000 psi	5 mins	3,000 psi	5 mins	Tests done. Jun-09
Middle pipe rams	3,000 psi	5 mins	3,000 psi	5 mins	Tests done. Jun-09
Upper pipe rams	3,000 psi	5 mins	3,000 psi	5 mins	Tests done. Jun-09
Shear rams	3,000 psi	5 mins	3,000 psi	5 mins	Tests done. Jun-09
Casing shear rams	4,000 psi	10 mins	4,000 psi	10 mins	Tests done. May-10
LMRP connector Primary	3,000 psi	5 mins	3,000 psi	5 mins	Tests done. Jun-09
LMRP connector Secondary	3,000 psi	5 mins			Tests done. Jun-09
C&K connector Primary	3,000 psi	5 mins	3,000 psi	5 mins	Tests done. Jun-09
C&K connector Secondary	3,000 psi	5 mins			Tests done. Jun-09
Pod lock, yellow pod	N/A	N/A	N/A	N/A	
Pod lock, blue pod	N/A	N/A	N/A	N/A	
Lower Annular	N/A	N/A	N/A	N/A	
Upper Annular	3,000 psi	5 mins	3,000 psi	5 mins	Tests done. Jun-09
Lower inner choke	3,000 psi	10 mins	3,000 psi	10 mins	Tests done. Dec-09
Lower outer choke	3,000 psi	10 mins	3,000 psi	10 mins	Tests done. Dec-09
Upper inner choke	3,000 psi	10 mins	3,000 psi	10 mins	Tests done. Dec-09
Upper outer choke	3,000 psi	10 mins	3,000 psi	10 mins	Tests done. Dec-09
Lower inner kill	3,000 psi	20 mins	3,000 psi	20 mins	Tests done. Jun-09

WEST ©

Item	Open/Unlock Chamber		Close/Lock Chamber		Comments
	Pressure	Time	Pressure	Time	
Lower outer kill	3,000 psi	20 mins	3,000 psi	20 mins	Tests done. May-10
Upper inner kill	3,000 psi	20 mins	3,000 psi	20 mins	Tests done. Jun-09
Upper outer kill	3,000 psi	20 mins	3,000 psi	20 mins	Tests done. Jun-09
Inner annular bleed	3,000 psi	20 mins	3,000 psi	20 mins	Tests done. Jun-09
Outer annular bleed	3,000 psi	20 mins	3,000 psi	20 mins	Tests done. Jun-09
Choke isolation valve	3,000 psi	20 mins	3,000 psi	20 mins	Tests done. Jun-09
Kill isolation valve	3,000 psi	10 mins	3,000 psi	10 mins	Tests done. Dec-09
Ram locking device e.g. MPL	3,000 psi	5 mins	3,000 psi	5 mins	Tests done. Jun-09
Item	Retract		Extend		Comments
Riser and BOP stack stinger, yellow pod.	3,000 psi	5 mins	3,000 psi	5 mins	Tests done. Jun-09
Riser and BOP stack stinger, blue pod.	3,000 psi	5 mins	3,000 psi	5 mins	Tests done. Jun-09
Item	Energize		De-energize		Comments
Riser and BOP stack stinger, yellow pod.					
Riser and BOP stack stinger, blue pod.					
Vetco CSO Diverter	1,500 psi	5 mins	1,500 psi	5 mins	Done. Mar-07

P.O. Box 577
Brookshire, Texas 77423
U.S.A



Tel: (281) 375-5515
Fax: (281) 934-1600
west@westengineer.com

ISO9001:2008 Certified

To: Paul.king1@deepwater.com ; discover@bp.com ;
stoltzd@bp.com ; holvork@bp.com ; lemairdw@bp.com ;
trent.fleece@bp.com ;

Date: 28 April 2010

Copy: Greg Childs, WEST Engineering Services

From: David Moore, James Regan—WEST Engineering Services

Page 1 of 1

FORM WES-OP-001

gc

REV

09/2009

**Daily Report #1 — Discoverer Enterprise
WEST Job #3925**

27-Apr-10

James Regan traveled left Sao Paulo, Brazil to Houston Texas.

David Moore traveled to New Orleans Louisiana. from Houston, Texas.

28-Apr-10

David Moore arrived onboard the rig at 14.40. Attended the Transocean safety orientation and the BP safety orientation. Discussed the upcoming survey with the BP company man and the Transocean toolpushers.

James Regan arrived in Houston and traveled to New Orleans, Louisiana.

Recommendations :

None.

Best Regards,

David Moore, James Regan
WEST Technical Specialist

To: Paul.king1@deepwater.com ; discover@bp.com ;
stoltzd@bp.com ; holvork@bp.com ; lemairdw@bp.com ;
trent.fleece@bp.com ;

Date: 29 April 2010

Copy: Greg Childs, WEST Engineering Services

From: David Moore, James Regan-WEST Engineering Services

LS

Page 1 of 1

FORM WES-OP-001 REV
09/2009

**Daily Report #2 — Discoverer Enterprise
WEST Job #3925**

Workscope Accomplished:

- The rig continues to pull the BOP to surface.
- WEST met with the *Discoverer Enterprise* subsea engineer to discuss the upcoming EOW maintenance procedure.
- Performed a visual inspection of the BOP HPU.
- Performed a visual inspection of the BOP high pressure test unit.
- James Regan arrived onboard the rig today.
- Discussed *Deep Water Horizon* well options with BP rig management.

Recommendations :

1. WEST performed a visual inspection of the BOP HPU. It was noted that the pressure relief valves on the unit did not have certification tags installed on the valves. WEST recommended that the pressure relief valves are recertified or replaced.
2. A visual inspection was performed on the BOP high pressure test unit. It was noted the pressure gauges did not have a calibration date sticker affixed. WEST recommended that the pressure gauges are recertified or replaced.
3. The hotline hose reel panel was observed to have a cracked gauge face. The gauge will need to be replaced when the BOP is on deck.

Discussion :

WEST performed a visual inspection of the BOP HPU. It was noted that the pressure relief valves on the unit did not have certification tags installed on the valves. WEST recommended that the pressure relief valves are recertified or replaced. The surface mounted accumulator bottles were observed to be in good condition. Certification for the accumulator bottles will be provided during this survey. An in-depth inspection of the HPU will be performed after the BOP stack is on deck.

A visual inspection was performed on the BOP high pressure test unit. It was noted the pressure gauges did not have a calibration date sticker affixed. WEST recommended that the pressure gauges are recertified or replaced. An in-depth inspection of the BOP high pressure test unit will be performed while pressure testing the BOP on deck.

The hotline hose reel panel was observed to have a cracked gauge face. The gauge will need to be replaced when the BOP is on deck.

Discussed with well site management, various options to be performed on the *Deep Water Horizon* well. WEST will attend a meeting tomorrow morning to discuss the options.

Transocean require to procure an inspection camera in order to ascertain the condition of the drill through equipment elastomers. WEST informed BP and Transocean that WEST could supply an inspection camera from their headquarters in Brookshire TX. A call was made to WEST Tech Service Manager, who in turn organized the delivery of the inspection camera to PHI-BP check-in, Houma LA.

Projected Workscope :

1. Attend BP meeting concerning the *Discoverer Enterprise* operations on the *Deep Water Horizon* well.
2. Perform the EOW maintenance procedures on the BOP.

Best Regards,

David Moore, James Regan
WEST Technical Specialist

To: Paul.king1@deepwater.com ; discover@bp.com ;
stoltzd@bp.com ; holvork@bp.com ; lemairdw@bp.com ;
trent.fleece@bp.com ;

Date: 30 April 2010

Copy: Greg Childs, WEST Engineering Services

From: David Moore, James Regan—WEST Engineering Services PK Page 1 of 3

FORM WES-OP-001 REV
09/2009

**Daily Report #3 — Discoverer Enterprise
WEST Job #3925**

Workscope Accomplished:

- Attempted to perform an EDS mode 2 from the subsea shop panel.
- Visually inspected the auxiliary line hoses in the moonpool. All Coflexip type hoses were found to be damaged and will need to be replaced.
- Removed the wellhead connector funnel from the stack in preparation to remove the DWHC wellhead connector and install an HC connector.

Recommendations :

1. The Coflexip type hoses in the moonpool were visually inspected. All hoses in the moonpool were observed to have damage to the outer protective sheath. It is recommended that all moonpool Coflexip type hoses are replaced as soon as practical. Reference API RP 53, 3rd Edition, Section 18.10.2, MMS CFR Title 30, Chapter II, Section 250.446, Paragraph (a).
2. It was noted that the moonpool hoses did not have safety slings installed. It is recommended that safety slings be installed from the rig hard piping to the Coflexip type hoses. Reference IADC Safety Alert 00-24.
3. The riser on deck was spot checked. Several buoyancy module thrust collars were found to be bent and will need to be repaired or replaced, the thrust collar nuts and bolts were found to be corroded and will need to be replaced.
4. Several buoyancy modules were observed to be damaged; it is recommended that these damaged modules be repaired.

Discussion :

The subsea engineer performed a mode 1 EDS. A mode 1 EDS is selected when there is no pipe in the hole. The lower shear rams are closed, the riser connector is unlocked, the pod stingers are retracted and the seals are de-energized and all stack functions go to the block position. The blue pod SEM A was selected and the BOP stack functions were put into the drilling mode. Once the EDS was selected a total of 28 gallons was used and the total time to operate was 25 seconds. EDS mode 1 was successfully performed from the blue pod SEM A.

A mode 2 EDS was attempted. A mode 2 EDS is selected under normal drilling operations. The casing shear rams are closed, the upper blind shear rams are closed, the riser connector is unlocked and the pod stingers are retracted and theseals are de-energized and allstack functions go to the block position. During the EDS, fluid was observed coming out of the tattle-tale port on the forward casing shear ram bonnet. The piston seals were leaking. The subsea engineer shut down the EDS and is the process of procuring the proper seal kit to be installed.

Further testing of the control system EDS functions (mode 2 – Casing and Upper Shear Ram) revealed that the casing shear ram high pressure function would not operate, troubleshooting indicated that the quarter inch pod valve in the yellow control pod was faulty, the valve was changed and testing continued. The casing shear ram still would not function whilst in mode 2. Further troubleshooting was ongoing which included the inspection of the HP casing shear close SPM. Attachment A shows the event logger print out of the EDS mode 2 sequence with time log, the LMRP unlatched at +/- 34 Seconds using 28 gallons total time used to complete the EDS sequence was 44 seconds.

The Coflexip type hoses in the moonpool were visually inspected. All hoses in the moonpool were observed to have damage to the outer protective sheath, and will need to be replaced. It was also noted that the moonpool hoses did not have safety slings installed. Safety slings should be installed from the rig hard piping to the Coflexip type hoses. Reference IADC Safety Alert 00-24. See Figures 1 and 2.

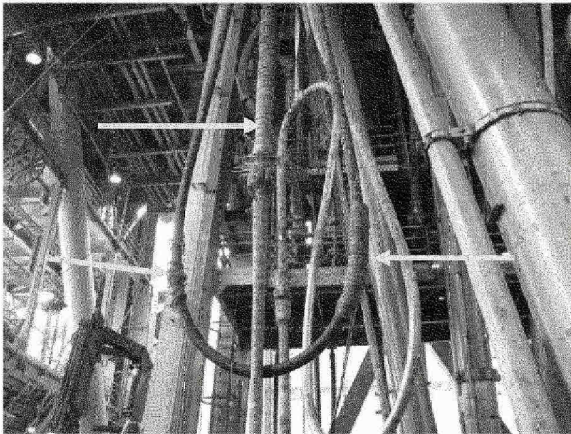

Figure 1: Damaged moonpool Coflexip type hoses



Figure 2: Damaged outer sheath on the moonpool hose.

The riser on deck was spot checked. The overall condition of the riser was in satisfactory condition. Several buoyancy module thrust collars were found to be bent and will need to be repaired or replaced, the thrust collar nuts and bolts were found to be corroded and should be replaced.

Several buoyancy modules were observed to be damaged; these damaged modules should be repaired. See Figure 3.

The wellhead connector guide funnel was supported with chain falls and all screw fasteners removed, the guide funnel was in turn lowered onto support blocks. The wellhead connector API flange studs were loosened with the hydraulic torque wrench, the wellhead connector test stump was engaged using the test joint and the connector was latched. The weight of the wellhead connector will be supported using the test stump and test joint with the deck crane.

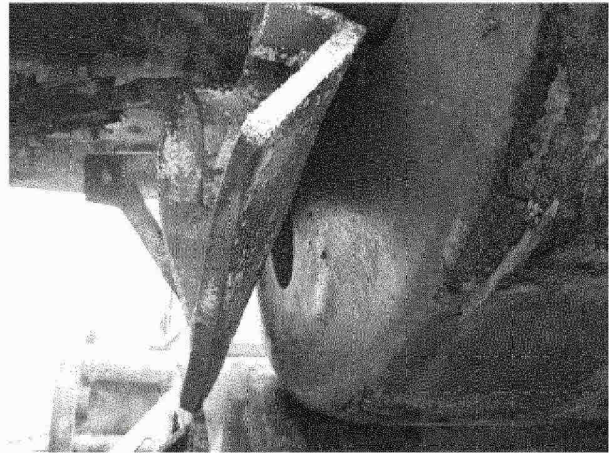

Figure 3: Damaged riser buoyancy thrust collar.

Projected Workscope :

1. Attend BP meeting concerning the *Discoverer Enterprise* operations on the Horizon well.
2. Perform the EOW maintenance procedures on the BOP.
3. Remove the current DWHC wellhead connector and replace it with a Cameron HC collet connector.
4. Perform an EDS in mode 1, mode 2 and mode 3 from the subsea shop panel, drillers panel and toolpushers panel.
5. Pressure test the BOP stack to MWP.
6. Pressure test the choke and kill manifold to MWP.
7. Verify ROV panel functionality.
8. While pressure testing the BOP stack, verify the pressure/temperature transducer mounted on the BOP stack is working properly.

Attachments :

A- EDS Mode #2 event logger print out.

Best Regards,

David Moore, James Regan
WEST Technical Specialist

EDS Mode #2 Event Logger Print Out

2010.04.30 /20:00:00Start of Log File2010043020.log. Event Logger Version 8.1 11/06/2002
 IniFile Name: TOE_EL.ini ProjectName: Transocean Enterpri se Revision Date: 6 Oct09 Translation:
 NONE

2010.04.30 /20:44:41 SSEP Enableon Subsea Panel :OFF--> ON
 Startedfinal EDS(2) in SSEP B :Normal State --> New alarm
 2010.04.30 /20:44:41 LMRPInclination X-Direction from SEM Blue A : -0.12 --> -1.07 degree
 2010.04.30 /20:44:41 LMRPInclinationX-Direction from SEM Blue B : -0.12 -->-1.07degree
 2010.04.30 /20:44:41 SSEPAuto Arm Relay : OFF-->ON
 Startedfinal EDS(2) in SSEP A : Normal State --> New alarm
 2010.04.30 /20:44:41 Multiple Valve Cmd From: SSEP BTo: Both Pods
 LMRP Connector--> unlock
 LMRP Connector Sec. -->unlock
 LMRP AnnularPreventer -->unlock
 LMRP Gasket Release -->unlock
 Inner Annular BleedValve--> unlock
 OuterAnnular BleedValve -->unlock
 Choke/Kill Isolation Valve -->unlock
 Choke/Kill Stabs --> unlock
 Wellbore P/T Connector --> unlock
 Mud Boost Valve--> unlock
 HPLMRP Connector--> unlock
 LMRP Disconnect Indicator-->unlock
 LMRP Disconnect Test -->unlock
 LowerInner Kill Valve -->unlock
 LowerOuterKill Valve-->unlock
 LowerInner ChokeValve--> unlock
 LowerOuter ChokeValve--> unlock
 Upper InnerKill Valve -->unlock
 UpperOuterKill Valve-->unlock
 Upper Inner ChokeValve--> unlock
 UpperOuter ChokeValve--> unlock
 Stack ConnectorPrimary --> unlock
 Stack ConnectorSecondary-->unlock
 Stack Conn. Gasket Release -->unlock
 StackAccumulator -->unlock
 Stack Stinger --> unlock
 Stack Stinger Seals--> unlock
 LMRP Stinger -->unlock
 LMRP StingerSeals--> unlock
 Pod Select Valve --> unlock
 Deadman-->unlock
 Solenoid ValveSupply -->unlock
 Solenoid ValveSupply Dump--> unlock
 Main Conduit Isolator -->unlock
 Rigid Conduit FlushValve--> unlock
 HotLine Isolator --> unlock
 UpperPipe Ram Preventer -->unlock
 MiddlePipe Ram Preventer -->unlock
 LowerPipe Ram Preventer -->unlock
 HPShear Enable --> unlock
 UpperShear Ram Preventer-->unlock
 UpperShear Ram - HP Close -->unlock
 LowerShear Ram Preventer-->unlock
 LowerShear Ram - HP Close -->unlock
 CasingShear Ram Preventer-->unlock

CasingShear Ram - HP Close -->unlock
 Annular PilotPressure -->unlock
 2010.04.30 /20:44:41 Multiple Valve Cmd From: SSEPA To: Both Pods
 LMRP Connector--> unlock
 LMRP Connector Sec. -->unlock
 LMRP AnnularPreventer -->unlock
 LMRP Gasket Release -->unlock
 Inner Annular BleedValve--> unlock
 OuterAnnular BleedValve -->unlock
 Choke/Kill Isolation Valve -->unlock
 Choke/Kill Stabs --> unlock
 Wellbore P/T Connector --> unlock
 Mud Boost Valve--> unlock
 HPLMRP Connector--> unlock
 LMRP Disconnect Indicator-->unlock
 LMRP Disconnect Test -->unlock
 LowerInner Kill Valve -->unlock
 LowerOuterKill Valve-->unlock
 LowerInner ChokeValve--> unlock
 LowerOuter ChokeValve--> unlock
 Upper InnerKill Valve -->unlock
 UpperOuterKill Valve-->unlock
 Upper Inner ChokeValve--> unlock
 UpperOuter ChokeValve--> unlock
 Stack ConnectorPrimary --> unlock
 Stack ConnectorSecondary-->unlock
 Stack Conn. Gasket Release -->unlock
 StackAccumulator -->unlock
 Stack Stinger --> unlock
 Stack Stinger Seals--> unlock
 LMRP Stinger -->unlock
 LMRP StingerSeals--> unlock
 Pod Select Valve --> unlock
 Deadman-->unlock
 Solenoid ValveSupply -->unlock
 Solenoid ValveSupply Dump--> unlock
 Main Conduit Isolator -->unlock
 Rigid Conduit FlushValve--> unlock
 HotLine Isolator --> unlock
 UpperPipe Ram Preventer -->unlock
 MiddlePipe Ram Preventer -->unlock
 LowerPipe Ram Preventer -->unlock
 HPShear Enable --> unlock
 UpperShear Ram Preventer-->unlock
 UpperShear Ram - HP Close -->unlock
 LowerShear Ram Preventer-->unlock
 LowerShear Ram - HP Close -->unlock
 CasingShear Ram Preventer-->unlock
 CasingShear Ram - HP Close -->unlock
 Annular PilotPressure -->unlock

 2010.04.30 /20:44:42 Multiple Valve Cmd From: SSEPA To: Both Pods
 CasingShear Ram Preventer-->vent
 CasingShear Ram - HP Close --> close
 2010.04.30 /20:44:43 Multiple Valve Cmd From: SSEP BTo: Both Pods
 CasingShear Ram Preventer-->vent
 CasingShear Ram - HP Close --> close

2010.04.30 /20:44:43 SEMYellow A Casing Shear Ram - HP Closevent --> close

2010.04.30 /20:44:43 SEM BlueA Casing Shear Ram - HP Closevent--> close
 2010.04.30 /20:44:43 SEM Blue B Casing Shear Ram - HP Closevent--> close

2010.04.30 /20:44:43 SEMYellow B Casing Shear Ram - HP Closevent --> close

2010.04.30 /20:44:44 SingleValve Cmd From: SSEPATo: Both Pods
 LMRP Gasket Release -->hold

2010.04.30 /20:44:44 SingleValve Cmd From: SSEP BTo: Both Pods
 LMRP Gasket Release -->hold

2010.04.30 /20:44:45 SingleValve Cmd From: SSEPATo: Both Pods
 LMRP Disconnect Indicator--> energize

2010.04.30 /20:44:45 Surface mixed fluidflow: start of flow from HPUA

2010.04.30 /20:44:45 SingleValve Cmd From: SSEP BTo: Both Pods
 LMRP Disconnect Indicator--> energize

2010.04.30 /20:44:46 SEM BlueA LMRP Disconnect Indicator vent-->energize

2010.04.30 /20:44:46 SEM Yellow B LMRP Disconnect Indicatorvent --> energize

2010.04.30 /20:44:46 SEM Blue B LMRP Disconnect Indicator vent-->energize
 2010.04.30 /20:44:46 SEM Yellow ALMRP Disconnect Indicatorvent -->energize

2010.04.30 /20:44:46 Multiple Valve Cmd From: SSEPA To: Both Pods
 Upper Inner ChokeValve--> close
 UpperOuter ChokeValve--> close

2010.04.30 /20:44:47 Multiple Valve Cmd From: SSEP BTo: Both Pods
 Upper Inner ChokeValve--> close
 UpperOuter ChokeValve--> close

2010.04.30 /20:44:47 Multiple Valve Cmd From: SSEPA To: Both Pods
 Upper InnerKill Valve --> close
 UpperOuterKill Valve--> close

2010.04.30 /20:44:48 Multiple Valve Cmd From: SSEP BTo: Both Pods
 Upper InnerKill Valve --> close
 UpperOuterKill Valve--> close

2010.04.30 /20:44:48 Multiple Valve Cmd From: SSEPA To: Both Pods
 LowerInner ChokeValve--> close
 LowerOuter ChokeValve--> close

2010.04.30 /20:44:48 Multiple Valve Cmd From: SSEP BTo: Both Pods
 LowerInner ChokeValve--> close
 LowerOuter ChokeValve--> close

2010.04.30 /20:44:49 Multiple Valve Cmd From: SSEPA To: Both Pods
 LowerInner Kill Valve --> close
 LowerOuterKill Valve--> close

2010.04.30 /20:44:49 Multiple Valve Cmd From: SSEP BTo: Both Pods
 LowerInner Kill Valve --> close

LowerOuterKill Valve--> close

2010.04.30 /20:44:51 Startedfinal EDS in SSEPA : New alarm -->Acknowledged
 2010.04.30 /20:44:51 Startedfinal EDS in SSEP B : New alarm -->Acknowledged

2010.04.30 /20:44:53 Multiple Valve Cmd From: SSEPA To: Both Pods
 Upper Inner ChokeValve--> vent
 UpperOuter ChokeValve--> vent

2010.04.30 /20:44:53 Multiple Valve Cmd From: SSEP BTo: Both Pods
 Upper Inner ChokeValve--> vent
 UpperOuter ChokeValve--> vent

2010.04.30 /20:44:54 SEM YellowAUpper Inner ChokeValve close --> vent
 SEM YellowAUpper Outer ChokeValve close --> vent
 2010.04.30 /20:44:54 CC4 Valve Cmd Answer back Q 0/6
 2010.04.30 /20:44:54 SEM BlueAUpper Inner Choke Valve close -->vent
 SEM Blue A Upper Outer ChokeValve close -->vent
 2010.04.30 /20:44:54 SEM Blue B UpperInner Choke Valve close -->vent
 SEM Blue BUpper Outer ChokeValve close -->vent
 2010.04.30 /20:44:54 SEMYellow BUpper Inner ChokeValve close--> vent
 SEM Yellow BUpperOuter ChokeValve close--> vent

ree

2010.04.30 /20:44:56 Multiple Valve Cmd From: SSEPA To: Both Pods
 Upper InnerKill Valve -->vent
 UpperOuterKill Valve-->vent

2010.04.30 /20:44:56 Multiple Valve Cmd From: SSEP BTo: Both Pods
 Upper InnerKill Valve -->vent
 UpperOuterKill Valve-->vent

2010.04.30 /20:44:56 CC3 Valve Cmd Answer back Q 0/6
 2010.04.30 /20:44:56 SEMYellowAUpper InnerKill Valve close -->vent
 SEM YellowAUpper OuterKill Valve close -->vent

2010.04.30 /20:44:57 SEM Blue AUpper Inner Kill Valve close -->vent
 SEM Blue A Upper OuterKill Valve close --> vent
 2010.04.30 /20:44:57 SEM Blue BUpperInner Kill Valve close -->vent
 SEM Blue BUpper OuterKill Valve close --> vent
 2010.04.30 /20:44:57 CC3 Valve Cmd Answer back Q 0/6
 2010.04.30 /20:44:57 SEMYellow BUpperInner Kill Valve close --> vent
 SEM Yellow BUpperOuterKill Valve close -->vent

2010.04.30 /20:44:58 Multiple Valve Cmd From: SSEPA To: Both Pods
 LowerInner ChokeValve--> vent
 LowerOuter ChokeValve--> vent
 UpperShear Ram Preventer-->vent
 UpperShear Ram - HP Close --> close
 2010.04.30 /20:44:58 Multiple Valve Cmd From: SSEP BTo: Both Pods
 LowerInner ChokeValve--> vent
 LowerOuter ChokeValve--> vent
 UpperShear Ram Preventer-->vent
 UpperShear Ram - IIP Close --> close
 2010.04.30 /20:44:58 CC3 Valve Cmd Answer back Q 0/6
 2010.04.30 /20:44:58 SEMYellow A Lower Inner ChokeValve close --> vent
 SEM YellowA Lower Outer ChokeValve close --> vent
 SEM YellowAUpper Shear Ram Preventeropen--> vent
 SEM YellowAUpper Shear Ram -HP Closevent --> close

2010.04.30 /20:44:59 SEMYellow B Lower Inner ChokeValve close --> vent
 SEM Yellow B Lower Outer ChokeValve close --> vent
 SEM Yellow BUpperShear Ram Preventeropen --> vent
 SEM Yellow BUpperShear Ram - HP Close vent--> close
 2010.04.30 /20:44:59 SEM BlueA LowerInner Choke Valve close -->vent
 SEM Blue A LowerOuter ChokeValve close -->vent
 SEM Blue A Upper Shear Ram Preventer open--> vent
 SEM Blue A Upper Shear Ram - HP Closevent--> close

 2010.04.30 /20:44:59 SEM Blue B Lower Inner Choke Valve close -->vent
 SEM Blue B LowerOuter ChokeValve close -->vent
 SEM Blue BUpper Shear Ram Preventer open--> vent
 SEM Blue BUpper Shear Ram - HP Closevent--> close

 2010.04.30 /20:44:59 Multiple Valve Cmd From: SSEPA To: Both Pods
 LowerInner Kill Valve -->vent
 LowerOuterKill Valve-->vent
 2010.04.30 /20:44:59 Multiple Valve Cmd From: SSEP BTo: Both Pods
 LowerInner Kill Valve -->vent
 LowerOuterKill Valve-->vent

 2010.04.30 /20:45:00 SEMYellowA Lower InnerKill Valve close -->vent
 SEM YellowA Lower OuterKill Valve close -->vent
 2010.04.30 /20:45:00 SEMYellow B Lower InnerKill Valve close -->vent
 SEM Yellow B Lower OuterKill Valve close -->vent
 2010.04.30 /20:45:00 SEM Blue A LowerInner Kill Valve close -->vent
 SEM Blue A LowerOuterKill Valve close --> vent
 2010.04.30 /20:45:00 SEM Blue B Lower Inner Kill Valve close -->vent
 SEM Blue B LowerOuterKill Valve close --> vent

 2010.04.30 /20:45:00 Multiple Valve Cmd From: SSEPA To: Both Pods
 LMRP AnnularPreventer -->vent
 Stack ConnectorPrimary --> vent

 2010.04.30 /20:45:00 Multiple Valve Cmd From: SSEP BTo: Both Pods
 LMRP AnnularPreventer -->vent
 Stack ConnectorPrimary --> vent

 2010.04.30 /20:45:01 SEMYellow A LMRP Annular Preventeropen --> vent

 2010.04.30 /20:45:01 Multiple Valve Cmd From: SSEPA To: Both Pods
 Stack Conn. Gasket Release -->vent
 CasingShear Ram Preventer-->vent
 CasingShear Ram - HP Close -->vent

 2010.04.30 /20:45:01 SEMYellow B LMRP Annular Preventer open--> vent
 2010.04.30 /20:45:01 Multiple Valve Cmd From: SSEP BTo: Both Pods
 Stack Conn. Gasket Release -->vent
 CasingShear Ram Preventer-->vent
 CasingShear Ram - HP Close -->vent
 2010.04.30 /20:45:01 SEM Blue A LMRP Annular Preventeropen --> vent

 2010.04.30 /20:45:02 SEMYellow A Casing Shear Ram - HP Close close -->vent

 2010.04.30 /20:45:02 SEM Blue B Casing Shear Ram - HP Close close -->vent

2010.04.30 /20:45:02 SEMYellow B Casing Shear Ram - HP Close close -->vent
 2010.04.30 /20:45:02 SEM BlueA Casing Shear Ram - HP Close close -->vent

 2010.04.30 /20:45:05 SingleValve Cmd From: SSEPATo: Both Pods
 Choke/Kill Stabs --> retract
 2010.04.30 /20:45:05 SingleValve Cmd From: SSEP BTo: Both Pods
 Choke/Kill Stabs --> retract

 2010.04.30 /20:45:05 SEMYellowA Choke/Kill Stabs extend--> retract

 2010.04.30 /20:45:05 SEM Blue A Choke/Kill Stabs extend -->retract
 2010.04.30 /20:45:05 SEM Blue B Choke/Kill Stabs extend -->retract

 2010.04.30 /20:45:05 SEMYellow B Choke/Kill Stabs extend--> retract

 2010.04.30 /20:45:06 SingleValve Cmd From: SSEP BTo: Both Pods
 Wellbore P/T Connector --> retract
 2010.04.30 /20:45:07 SingleValve Cmd From: SSEPATo: Both Pods
 Wellbore P/T Connector --> retract

 2010.04.30 /20:45:07 SEMBlue A Wellbore P/TConnectorextend--> retract
 2010.04.30 /20:45:07 SEM Blue BWellboreP/T Connector extend -->retract
 2010.04.30 /20:45:07 SEMYellow A Wellbore P/T Connector extend --> retract
 2010.04.30 /20:45:07 SEMYellow BWellbore P/T Connector extend --> retract

 2010.04.30 /20:45:07 Conduit Supply Pressure from SEM Blue B : 3525--> 3148 psi
 2010.04.30 /20:45:07 Multiple Valve Cmd From: SSEP BTo: Both Pods
 LowerShear Ram Preventer-->vent
 LowerShear Ram - HP Close -->vent
 2010.04.30 /20:45:08 Multiple Valve Cmd From: SSEPA To: Both Pods
 LowerShear Ram Preventer-->vent
 LowerShear Ram - HP Close -->vent

 2010.04.30 /20:45:08 SEM Blue A Lower Shear Ram Preventer open--> vent
 2010.04.30 /20:45:08 SEM Blue B Lower Shear Ram Preventer open--> vent
 2010.04.30 /20:45:08 SEMYellow A Lower Shear Ram Preventeropen--> vent
 2010.04.30 /20:45:08 SEMYellow B Lower Shear Ram Preventeropen--> vent

 LowerPipe Ram Preventer -->vent

 2010.04.30 /20:45:08 SingleValve Cmd From: SSEPATo: Both Pods
 LowerPipe Ram Preventer -->vent

 2010.04.30 /20:45:09 SEM Blue B Lower Pipe Ram Preventeropen -->vent
 2010.04.30 /20:45:09 SEMYellow A Lower Pipe Ram Preventeropen --> vent

 2010.04.30 /20:45:09 SEMYellow B Lower Pipe Ram Preventeropen --> vent
 2010.04.30 /20:45:09 SEM BlueA LowerPipe Ram Preventeropen -->vent

 2010.04.30 /20:45:09 SingleValve Cmd From: SSEP BTo: Both Pods
 MiddlePipe Ram Preventer -->vent
 2010.04.30 /20:45:09 CC1 Valve Cmd Answer back Q 0/6
 2010.04.30 /20:45:09 SingleValve Cmd From: SSEPATo: Both Pods
 MiddlePipe Ram Preventer -->vent

2010.04.30 /20:45:10 SEMYellow B Middle Pipe Ram Preventeropen--> vent
 2010.04.30 /20:45:10 SEM BlueA Middle Pipe Ram Preventeropen -->vent
 2010.04.30 /20:45:10 SEM Blue B Middle Pipe Ram Preventeropen -->vent
 2010.04.30 /20:45:10 SEMYellow A Middle Pipe Ram Preventeropen--> vent
 2010.04.30 /20:45:10 SingleValve Cmd From: SSEP BTo: Both Pods
 UpperPipe Ram Preventer -->vent

 2010.04.30 /20:45:10 SingleValve Cmd From: SSEPATo: Both Pods
 UpperPipe Ram Preventer -->vent

 2010.04.30 /20:45:11 SEMYellow A Upper Pipe Ram Preventeropen --> vent
 2010.04.30 /20:45:11 SEMYellow BUpper Pipe Ram Preventer open--> vent
 2010.04.30 /20:45:11 SEM BlueAUpper Pipe Ram Preventeropen -->vent
 2010.04.30 /20:45:11 SEM Blue B Upper Pipe Ram Preventeropen -->vent

 HPLMRP Connector Readback Pressure from SEM Blue A : 2297--> 1891 psi

 2010.04.30 /20:45:12 Multiple Valve Cmd From: SSEP BTo: Both Pods
 StackAccumulator -->vent
 UpperShear Ram Preventer-->vent
 UpperShear Ram - HP Close -->vent

 2010.04.30 /20:45:12 Multiple Valve Cmd From: SSEPA To: Both Pods
 StackAccumulator -->vent
 UpperShear Ram Preventer-->vent
 UpperShear Ram - HP Close -->vent

 2010.04.30 /20:45:13 SEMYellow A Upper Shear Ram - IIP Close close -->vent

 2010.04.30 /20:45:13 Conduit Supply Pressure from SEM Yellow A : 2205--> 2732 psi
 2010.04.30 /20:45:13 SEM Yellow B UpperShear Ram - HP Close close--> vent
 2010.04.30 /20:45:13 SEM BlueA StackAccumulator charge --> vent
 SEM Blue A Upper Shear Ram - HP Close close -->vent
 2010.04.30 /20:45:13 SEM Blue B StackAccumulator charge --> vent
 SEM Blue BUpper Shear Ram - HP Close close -->vent

 2010.04.30 /20:45:14 Multiple Valve Cmd From: SSEPA To: Both Pods
 LMRP Connector--> vent
 HPLMRP Connector--> unlatch
 2010.04.30 /20:45:14 Conduit Supply Pressure from SEM Blue B : 2805--> 3193 psi
 2010.04.30 /20:45:14 Multiple Valve Cmd From: SSEP BTo: Both Pods
 LMRP Connector--> vent
 HPLMRP Connector--> unlatch
 2010.04.30 /20:45:14 BOP Manifold Readback Pressure from SEM Blue A :1951-->1563 psi
 2010.04.30 /20:45:14 Conduit Supply Pressure from SEM Yellow B :2866-->3264 psi
 2010.04.30 /20:45:14 HP LMRP Connector Readback Pressure from SEM Blue B : 3285--> 3658 psi

 2010.04.30 /20:45:14 SEM YellowA LMRP Connector latch--> vent
 SEM YellowAHPLMRP Connectorvent -->unlatch
 2010.04.30 /20:45:15 Cycle Count Error: ProcessDiag(): Cycle Count reporting LMRP Connector Connector is in an error state

 2010.04.30 /20:45:15 Surface accumulator pressure from HPU A: 4287--> 4095 psi
 2010.04.30 /20:45:15 SingleValve Cmd From: SSEPATo: Both Pods
 Stack Stinger Seals--> Deenergize

 2010.04.30 /20:45:15 SEM Blue B LMRP Connector latch -->vent

SEM Blue BHP LMRP Connectorvent--> unlatch

2010.04.30 /20:45:15 SEM Yellow B LMRP Connector latch-->vent
SEM Yellow BHP LMRP Connectorvent -->unlatch

2010.04.30 /20:45:15 SingleValve Cmd From: SSEP BTo: Both Pods
Stack Stinger Seals--> Deenergize

2010.04.30 /20:45:15 SEM Blue A LMRP Connector latch -->vent
SEM Blue A HP LMRP Connectorvent--> unlatch

2010.04.30 /20:45:16 SEM Yellow B Stack StingerSeals Energize --> Deenergize

2010.04.30 /20:45:16 SEM Blue BStack StingerSeals Energize -->Deenergize

2010.04.30 /20:45:16 SEM Yellow A Stack StingerSeals Energize --> Deenergize

2010.04.30 /20:45:16 SEM Blue A Stack StingerSeals Energize -->Deenergize

2010.04.30 /20:45:17 SingleValve Cmd From: SSEP BTo: Both Pods
Stack Stinger --> Retract

2010.04.30 /20:45:17 SingleValve Cmd From: SSEPATo: Both Pods
Stack Stinger --> Retract

2010.04.30 /20:45:18 SEM Blue BStack Stinger Extend--> Retract

2010.04.30 /20:45:18 SEMYellow A Stack Stinger Extend--> Retract
gree

2010.04.30 /20:45:18 SEMYellow BStack Stinger Extend--> Retract

2010.04.30 /20:45:18 SEM BlueA Stack Stinger Extend--> Retract

2010.04.30 /20:45:21 SingleValve Cmd From: SSEP BTo: Both Pods
LMRP AnnularPreventer -->open

2010.04.30 /20:45:21 SingleValve Cmd From: SSEPATo: Both Pods
LMRP AnnularPreventer -->open

2010.04.30 /20:45:21 Surface accumulator pressure from HPU A: 4095--> 3912 psi

2010.04.30 /20:45:21 SEM Blue A LMRP Annular Preventervent --> open

2010.04.30 /20:45:21 SEM Blue B LMRP Annular Preventervent --> open

2010.04.30 /20:45:21 SEMYellow A LMRP Annular Preventervent --> open

2010.04.30 /20:45:21 SEMYellow B LMRP Annular Preventer vent-->open

To: Paul.king1@deepwater.com ; discover@bp.com ;
stoltzd@bp.com ; holvork@bp.com ; lemairdw@bp.com ;
trent.fleece@bp.com ; Date: 30 April 2010

Copy: Greg Childs, WEST Engineering Services

From: David Moore, James Regan—WEST Engineering Services PK Page 1 of 3

FORM WES-OP-001 REV
09/2009

**Daily Report #4 — Discoverer Enterprise
WEST Job #3925**

Workscope Accomplished:

- The yellow pod casing shear ram high pressure close SPM valve spring was found to be broken. The spring was replaced and the valve was working properly. (See discussion section below).
- Started pre-charging the stack mounted accumulator bottles to 4,570 psi.
- The subsea department began greasing the stack mounted failsafe valves.
- Commenced opening up of the ram preventer bonnets to carry out inspection of the ram elastomers.
- Removed the DWHC connector from the guide funnel and stored to forward deck.
- The new HC collet connector was positioned in the moon pool in order to carry out pre installation operator pressure tests (HC data below).
Cameron HC Collet Connector
18-3/4 15M
P/N-615735-06 rev-06
S/N-400069363
CIW961411851-10
Pressure Tested – 4-29-10 Cameron Facility
- Carried out operator tests on the HC Collet connector prior to installation:
Primary Lock – 3,000 psi/10 minutes – Good Test
Primary Unlock – 3,000 psi/10 minutes – Good test
Secondary Unlock – 3,000 psi/10minutes – Test failed – See discussion.
All tests were charted and witnessed by WEST.

Recommendations :

1. Source a replacement Cameron HC Collet Connector as a back up and supply a replacement seal kit to rebuild the HC Collet Connector which failed its operator circuit tests.

Discussion :

Whilst conducting EDS testing of the BOPs control system, in mode #2 the casing shear rams did not function. Troubleshooting revealed that the casing shear ram 1-1/2inch SPM would not fire, the valve was disassembled and found to have a broken inner arbor spring.

A replacement spring was sourced and subsequently fitted to the valve assembly. Further testing of the EDS is ongoing and will be documented in the next daily report. See Figures 4.1 and 4.2.

Figure 4.3 refers to the Cameron HC Collet Connector delivered to the rig to be fitted into the wellhead connector position.

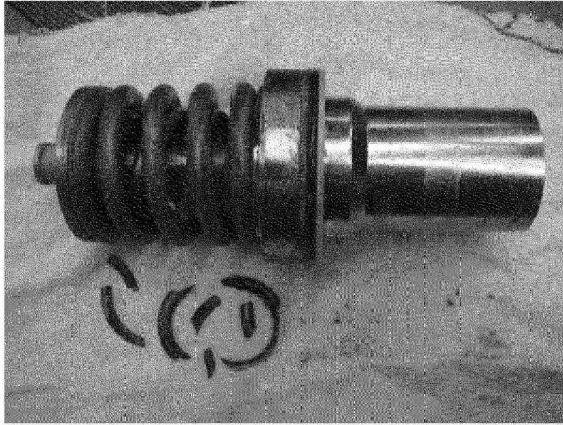

Figure 4.1. Shows the HP Casing Shear Close SPM with broken arbor spring.

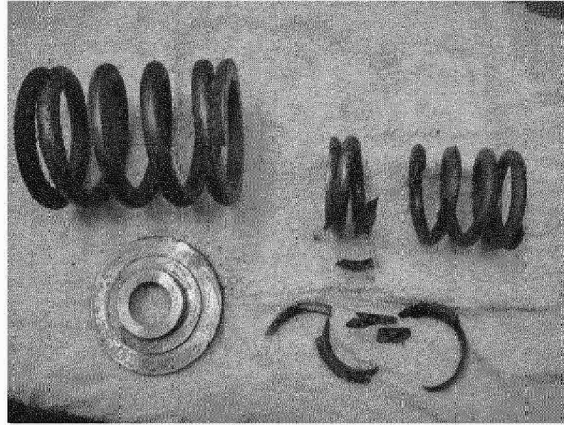

Figure 4.2: Shows the HP Casing Shear Close SPM dismantled.

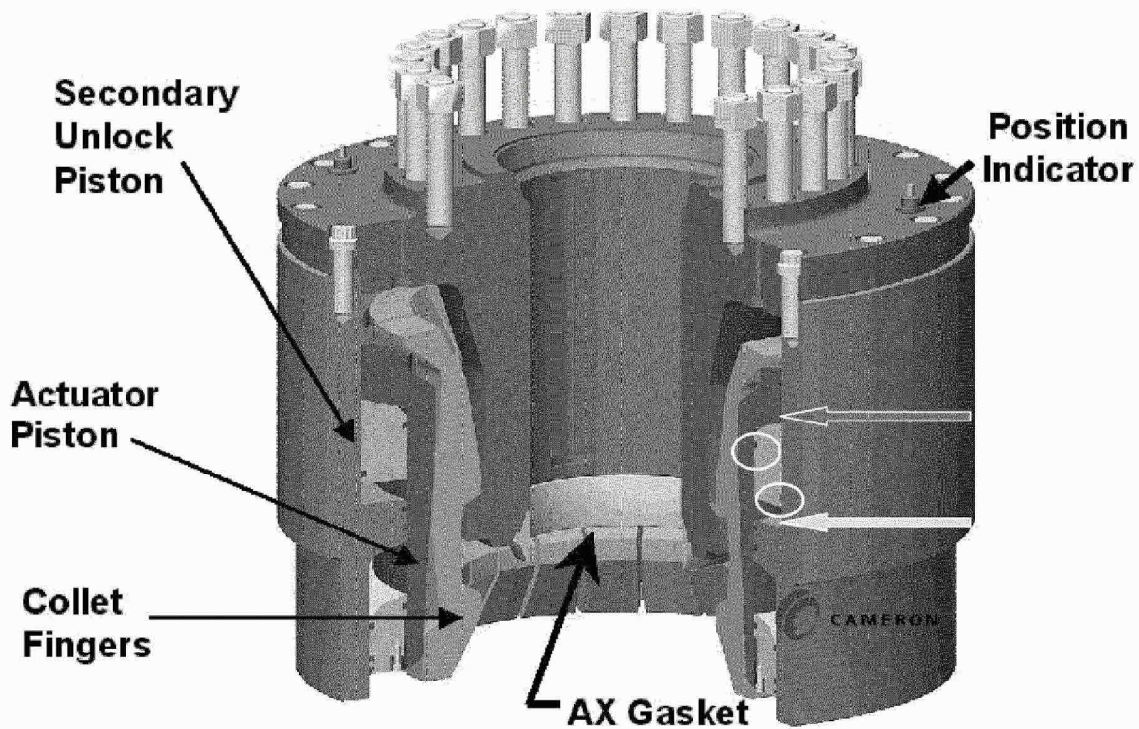

Figure 4.3: The yellow arrow shows the HC Collet Connector secondary unlatching cylinder, the two circles show the secondary piston seals, one of these two (or both) seals has failed causing operating fluid to migrate upward into the primary unlocking cylinder area, shown with the green arrow.

Prior to fitting the connector had operator pressure tests carried out to determine the integrity of the hydraulic circuits. The primary lock circuit and primary unlock circuit's were both successfully tested to 3,000 psi /10minutes. The secondary unlock circuit could not be tested and was found to be communicating with the primary unlock circuit, fluid was visible leaking back through the primary port at the connector head. The leak was witnessed by WEST and Transocean, pressure testing was suspended awaiting a response from the OEM and Transocean management.

The subsea department started pre-charging the stack mounted accumulator bottles to 4,570 psi. The bottles are being pre-charged with nitrogen.

Projected Workscope :

1. Attend BP meeting concerning the Discoverer Enterprise operations on the Horizon well.
2. Perform the EOW maintenance procedures on the BOP.
3. Remove the current DWHC wellhead connector and replace it with a Cameron HC collet connector.
4. Perform an EDS in mode 1, mode 2 and mode 3 from the subsea shop panel, drillers panel and toolpushers panel.
5. Pressure test the BOP stack to MWP.
6. Pressure test the choke and kill manifold to MWP.
7. Verify ROV panel functionality.
8. While pressure testing the BOP stack, verify the pressure/temperature transducer mounted on the BOP stack is working properly.
9. It was decided today (01 May 10) that all ram bonnets are to be opened and top seals and packers replaced.

Best Regards,

David Moore, James Regan
WEST Technical Specialist

To: Paul.king1@deepwater.com ; discover@bp.com ;
stoltzd@bp.com ; lemairdw@bp.com ; trent.fleece@bp.com ;

Date: 3 May 2010

Copy: Greg Childs, WEST Engineering Services

From: David Moore, James Regan—WEST Engineering Services

Page 1 of 3

FORM WES-OP-001 gc REV 09/2009

**Daily Report #5 — Discoverer Enterprise
WEST Job #3925**

Workscope Accomplished:

- The yellow pod annular regulator was observed to be leaking; the regulator was replaced with a rebuilt unit.
- The aft middle pipe ram MPL and the forward upper pipe ram MPL were tested and it was determined that the MPLs need to be disassembled and rebuilt. See Discussion.
- The Hydril Annuflex annular element was visually inspected by use of the WEST supplied *WESTScope* video camera. See Discussion.
- The fwd casing shear ram bonnet was removed in order to change the damaged main piston rod seal, the seal was changed, and the bonnet was rebuilt.
- The HC collet connector was removed from the set back area and dismantling commenced. (See Discussion).

Recommendations :

None.

Discussion :

A signature test was performed on the aft middle pipe ram open and close ports. The pressure to open or close should be in the 100-200 psi range. The pressure to open the ram was 380 psi. If a pressure greater than 200 psi is required to open or close the ram, the locks should be disassembled for inspection. The MPL was removed from the housing and both locknut bearings replaced. The aft middle pipe ram MPL has yet to be retested. See Figure 1.

A signature test was performed on the forward upper pipe ram MPL open and close ports. The opening pressure was recorded at 435 psi. The MPL was removed from the housing and both locknut bearings replaced. The forward upper pipe ram MPL has yet to be retested.



Figure 5.1: The aft middle pipe ram MPL locknut bearing that was replaced.

A signature test was performed on the lower blind shear rams, the pressure recorded to open the rams was 80 psi, and the closing pressure was 80 psi. The signature test pressures were acceptable. A signature test was performed on the upper blind shear rams, the pressure recorded to open the rams was 125 psi and the closing pressure was 120 psi. The signature test pressures were acceptable.

The Hydril Annuflex annular element was visually inspected by use of the WEST supplied *WESTScope* video camera. The camera was run into the bore of the annular and inspection commenced. The results were that the annular element is in good condition and does not need to be replaced at this time. The video of the inspection was given to the subsea engineer.

The Cameron HC Collet connector was removed from the set back area and prepared to be disassembled by the OEM, Cameron (See Figure 5.2). The body center section was removed from the body, while removing the center section, the collet cluster was fixed to the center section hub by way of cargo straps (See Figure 5.3). This will enable the connector to be rebuilt faster and with less manual handling of the collets while rebuilding. Further dismantling and inspection will be ongoing.

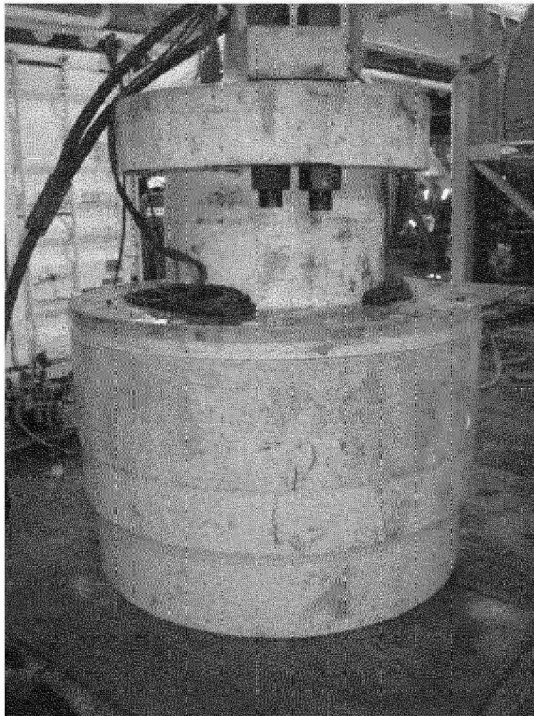

Figure 5.2: Shows the HC Connector prior to disassembly.



Figure 5.3: Shows the body section removed with collets secured to hub.

Projected Workscope :

1. Attend BP meeting concerning the Discoverer Enterprise operations on the Horizon well.
2. Perform the EOW maintenance procedures on the BOP.
3. Liaise with Cameron to effect repairs to the HC Collet connector.
4. Perform an EDS in mode 1, mode 2 and mode 3 from the subsea shop panel, drillers panel and toolpushers panel.
5. Pressure test the BOP stack to MWP.
6. Pressure test the choke and kill manifold to MWP.
7. Verify ROV panel functionality from all stack mounted hot stabs.
8. While pressure testing the BOP stack, verify the pressure/temperature transducer mounted on the BOP stack is working properly.
9. Continue changing out MPL ram packers.
10. Replace casing shear ram rod seals (fwd).
11. Finish torquing bonnet bolts.
12. Replace blown pod packer seals in the yellow pod.
13. Perform a deadman from both pods.

Best Regards,

David Moore, James Regan
WEST Technical Specialist

To: Paul.king1@deepwater.com ; discover@bp.com ; stoltzd@bp.com ; lemairdw@bp.com ; trent.fleece@bp.com ;

Date: 04 May 2010

Copy: Greg Childs, WEST Engineering Services

From: David Moore, James Regan—WEST Engineering Services

Page 1 of 3

FORM WES-OP-001 gc REV 09/2009

**Daily Report #6 — Discoverer Enterprise
WEST Job #3925**

Workscope Accomplished:

- A new 18-3/4" 15k Cameron HC Collet Connector was delivered to the rig early this morning to be installed in the wellhead connector position. See Discussion.
- The subsea department continues to precharge the stack mounted accumulator bottles with nitrogen to 4,570 psi.
- Completed final torque on casing shear Ram bonnet cap screws to 1,600ft/lbs after replacing leaking piston seal. Carried out operator tests on both open and close circuits to 3,000psi/ten minutes. Good Tests – All tests were charted and witnessed by WEST.

Recommendations :

None.

Discussion :

The new Cameron Collet Connector was delivered to the rig. Once on the rig, the connector operators were hydraulically pressure tested. The latch, unlatch and secondary unlatch ports were pressure tested to 3,000 psi for 10 minutes each. All tests were acceptable. The BOP stack was skidded over the connector and a new CX gasket was installed. The connector was raised onto the lower triple BOP flange. The studs were coated with Moly 503 and the nuts were torqued to 7,620 ft/lbs. The new connector information was as follows:

18-3/4" 15k Cameron HC Collet Connector
P/N 615626-05
S/N 96-1237237-10

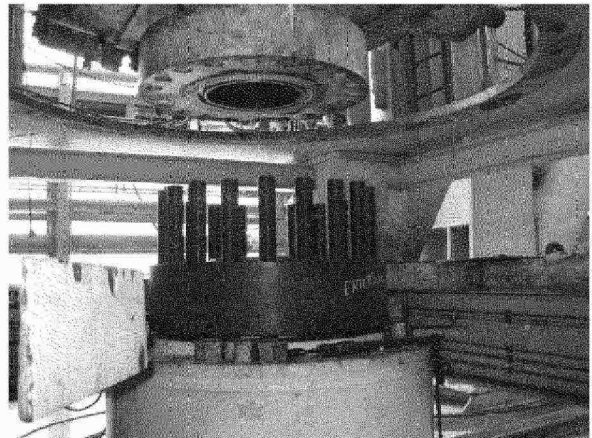

Figure 6.1: Installing the Cameron HC Collet Connector

The forward casing shear ram rod seals were replaced. The bonnet open and close ports have not been pressure tested. The rod seal kit used was P/N 3144589, batch #5991-3.

DISCOVERER ENTERPRISE BOP ELASTOMER TABLE – MAY 2010				
EQUIPMENT	COMPONENT	PART NUMBER	BATCH ID	EXPIRY DATE
UPPER SHEAR RAM	SEAL CARRIER O-RING	PN-3114949-03 4969-2 2014		
UPPER SHEAR RAM	SEAL CARRIER O-RING	PN-3114949-04 4576-2 2014		
UPPER SHEAR RAM	TOP SEAL	PN-3117111 REVA2	5866-2 2019	
UPPER SHEAR RAM	TOP SEAL	PN-3117112 REVA	5866-2 2019	
UPPER SHEAR RAM	LATERAL T-SEAL PN-3113891	REVH2	5961-3 2016	
LOWER SHEAR RAM	SEAL CARRIER O-RING	PN-3114949-03 1553-1 2015		
LOWER SHEAR RAM	SEAL CARRIER O-RING	PN-3114949-04 4969-2 2015		
LOWER SHEAR RAM	TOP SEAL	PN-3117111 REVA2	5012-3 2014	
LOWER SHEAR RAM	TOP SEAL	PN-3117112 REVA	5866-2 2014	
LOWER SHEAR RAM	LATERAL T-SEAL PN-3113891	REVH2	5691-6 2015	
CASING SHEARRAM	SEAL CARRIER O-RING	PN-3114949-03 5541-3 2015		
CASING SHEARRAM	SEAL CARRIER O-RING	PN-3114949-04 4576-2 2014		
UPPER PIPE RAMS SEAL CARRIER O-RING	PN-3114949-03	5405-2 2015		
UPPER PIPE RAMS SEAL CARRIER O-RING	PN-3114949-04	4576-2 2015		
UPPER PIPE RAMS-AFT	VBR PACKER 4-1/2"-7"	PN-3118845 REV N2	5924-3 SN-0210-0095 2016	
UPPER PIPE RAMS-FWD	VBR PACKER 4-1/2"-7"	PN-3118845 REV N2	5924-4 SN-0210-0088 2016	
UPPER PIPE RAMS TOP SEAL	PN-3117110	REVB4	5579-2 2014	
UPPER PIPE RAMS TOP SEAL	PN-3117110	REVB4	5579-3 2014	
MIDDLE PIPE RAMS SEAL CARRIER O-RING	PN-3114949-03	5405-2 2014		
MIDDLE PIPE RAMS SEAL CARRIER O-RING	PN-3114949-04	5541-3 2015		
MIDDLE PIPE RAMS-AFT	VBR PACKER 4-1/2"-7"	PN-3118845 REV N2	NO INFO	NO INFO
MIDDLE PIPE RAMS-FWD	VBR PACKER 4-1/2"-7"	PN-3118845 REV N2	NO INFO	NO INFO
MIDDLE PIPE RAMS-AFT	LATERAL T-SEAL PN-3117110	5579-3 2014		
MIDDLE PIPE RAMS-FWD	LATERAL T-SEAL PN-3117110	5532-2 2014		
LOWER PIPE RAM	SEAL CARRIER O-RING	PN-3114949-03 5341-2 2015		
LOWER PIPE RAM	SEAL CARRIER O-RING	PN-3114949-04 5405-2 2014		

Projected Workscope :

1. Attend BP meeting concerning the Discoverer Enterprise operations on the Horizon well.
2. Perform the EOW maintenance procedures on the BOP.
3. Perform an EDS in mode 1, mode 2 and mode 3 from the subsea shop panel, drillers panel and toolpushers panel.
4. Pressure test the BOP stack to MWP.
5. Pressure test the choke and kill manifold to MWP.
6. Verify ROV panel functionality from all stack mounted hot stabs.
7. While pressure testing the BOP stack, verify the pressure/temperature transducer mounted on the BOP stack is working properly.
8. Finish torquing casing ram bonnet bolts.
9. Replace blown pod packer seals in the yellow pod.
10. Perform a deadman from both pods.

Best Regards,

David Moore, James Regan
WEST Technical Specialist

To: Paul.king1@deepwater.com ; discover@bp.com ; stoltzd@bp.com ; lemairdw@bp.com ; trent.fleece@bp.com ;

Date: 5 May 2010

Copy: Greg Childs, WEST Engineering Services

From: David Moore, James Regan-WEST Engineering Services

Page 1 of 2

FORM WES-OP-001 REV
09/2009

**Daily Report #7 — Discoverer Enterprise
WEST Job #3925**

Workscope Accomplished:

- Cameron service technicians continue to rebuild the leaking Cameron HC Collet Connector.
- The subsea department continues to precharge the stack mounted accumulator bottles with nitrogen to 4,570 psi.
- Completed final torque on casing shear ram bonnet bolts to 2,000ft/lbs. Moly 503 was used to lubricate the bolts.
- The blown pod packer seals in the yellow pod were replaced with new seals.

Recommendations :

None.

Discussion :

The stack mounted accumulator bottles were precharged with nitrogen to the following pressure:

Stack accumulator bottles	4,570 psi
Pod pilot bottles	2,335 psi
Annular surge bottle	3,170 psi
HP LMRP pilot regulator Bottle	A 1,000 psi Bottle B 2,335 psi Bottle C 3,670 psi Bottle D 3,670 psi
Manifold regulator pilot	Bottle A 750 psi Bottle B 2,085 psi Bottle C 3,420 psi Bottle D 3,420 psi
Stack regulator pilot	Bottle A 300 psi Bottle B 1,635 psi Bottle C 2,970 psi Bottle D 2,970 psi
Annular regulator pilot	Bottle A 500 psi Bottle B 2,085 psi

	Bottle C 3,420 psi Bottle D 3,420 psi
LMRP connector regulator pilot	Bottle A 750 psi Bottle B 2,085 psi Bottle C 3,420 psi Bottle D 3,420 psi

The 5k to 4k HP casing shear ram regulator was removed from the BOP stack due to leaking seals. A repair kit or replacement regulator was not found on the rig. TOI attempted to source a repair kit or another regulator from the TOI fleet to no avail. The leaking regulator was installed back on the BOP stack so function testing and wellbore testing can proceed. Once a repair kit is sourced and sent to the rig the regulator will be rebuilt and tested.

Projected Workscope :

1. Attend BP meeting concerning the *Discoverer Enterprise* operations on the *Deep Water Horizon* well.
2. Perform the EOW maintenance procedures on the BOP.
3. Perform an EDS in mode 1, mode 2 and mode 3 from the subsea shop panel, drillers panel and toolpushers panel.
4. Pressure test the BOP stack to MWP.
5. Pressure test the choke and kill manifold to MWP.
6. Verify ROV panel functionality from all stack mounted hot stabs.
7. While pressure testing the BOP stack, verify the pressure/temperature transducer mounted on the BOP stack is working properly.
8. Perform a deadman from both pods.
9. Rebuild the 5k to 4k HP casing shear ram regulator.

Best Regards,

David Moore, James Regan
WEST Technical Specialist

To: Paul.king1@deepwater.com ; discover@bp.com ;
stoltzd@bp.com ; lemairdw@bp.com ; trent.fleece@bp.com ;

Date: 6 May 2010

Copy: Greg Childs, WEST Engineering Services

From: David Moore—WEST Engineering Services

Page 1 of 2

FORM WES-OP-001 REV
09/2009

**Daily Report #8 — Discoverer Enterprise
WEST Job #3925**

Workscope Accomplished:

- The subsea department completed the nitrogen precharge of the BOP stack and LMRP accumulator bottles.
- Replaced burst bladders on the stack mounted accumulator bottles.
- Successfully performed an EDS on the yellow pod.
- Pressure tested the annular and both bleed valves. See Discussion.

Recommendations :

1. None

Discussion :

Two MMS surveyors arrived onboard the rig this afternoon. MMS requested to witness the pressure testing of the annular and the inner and outer bleed valves. We were informed this morning that the BOP stack was not to be run and the LMRP was to be run during the next rig operations. The subsea department concentrated on completing the pressure testing of the annular and both bleed valves.

The BOP test stump was raised into the wellhead connector and latched in with 1,500 psi. A 5" test joint was used to pressure test the annular. The wellbore of the stack and LMRP was filled with water, the annular was closed the 1,500 psi closing pressure. The inner bleed valve was opened and the outer bleed valve was closed. After a few minor leaks on the BOP test unit, the annular and outer bleed valve was pressure tested to 250 psi for five minutes and 10,000 psi for ten minutes. The annular and inner bleed valve was then pressure tested to 250 psi for five minutes and 10,000 psi for ten minutes. The half-open tool was then installed on both valves, and a 250 psi for five minutes and 10,000 psi pressure test was performed. Since the WOM valve seals on the upstream and downstream of the gate the half-open tool keep the valve in the half-open position so the bonnet gasket can be pressure tested. The final test on the LMRP was the annular U seal, the U seal was pressure tested to 2,000 psi for ten minutes. All pressure tests were successful, charted and witnessed by WEST and MMS. The LMRP is now ready to be unlatched from the BOP and ready to run.

Projected Workscope :

1. Attend BP meeting concerning the *Discoverer Enterprise* operations on the Horizon well.
2. Perform the EOW maintenance procedures on the BOP.
3. Perform an EDS in mode 1, mode 2 and mode 3 from the subsea shop panel, drillers panel and toolpushers panel.
4. Pressure test the BOP stack to MWP.
5. Pressure test the choke and kill manifold to MWP.
6. Verify ROV panel functionality from all stack mounted hot stabs.
7. While pressure testing the BOP stack, verify the pressure/temperature transducer mounted on the BOP stack is working properly.
8. Perform a deadman from both pods.
9. Rebuild the 5K to 4K HP casing shear ram regulator.

Best Regards,

David Moore
WEST Technical Specialist

To: Paul.king1@deepwater.com ; discover@bp.com ;
stoltzd@bp.com ; lemairdw@bp.com ; trent.fleece@bp.com ;

Date: 7 May 2010gn

Copy: Greg Childs, WEST Engineering Services

From: David Moore—WEST Engineering Services

Page 1 of 1

FORM WES-OP-001 REY
09/2009

**Daily Report #9 — Discoverer Enterprise
WEST Job #3925**

Workscope Accomplished:

- The subsea department is in the process of preparing the LMRP for deployment.
- Reviewed ROV panel schematics and visually inspected the ROV panels on the BOP stack. The ROV panels will be function tested before the BOP stack is run.
- Attended a BP meeting concerning the upcoming well program.

Recommendations :

None

Projected Workscope :

1. Perform the EOW maintenance procedures on the BOP.
2. Perform an EDS in mode 1, mode 2 and mode 3 from the subsea shop panel, drillers' panel and toolpusher panel.
3. Pressure test the BOP stack to MWP.
4. Pressure test the choke and kill manifold to MWP.
5. Verify ROV panel functionality from all stack mounted hot stabs.
6. While pressure testing the BOP stack, verify the pressure/temperature transducer mounted on the BOP stack is working properly.
7. Rebuild the 5K to 4K HP casing shear ram regulator.

Best Regards,

David Moore
WEST Technical Specialist

To: Paul.king1@deepwater.com ; discover@bp.com ;
stoltzd@bp.com ; lemairdw@bp.com ; trent.fleece@bp.com ;

Date: 8 May 2010gn

Copy: Greg Childs, WEST Engineering Services

From: David Moore—WEST Engineering Services

Page 1 of 2

FORM WES-OP-001 REV
09/2009

**Daily Report #10 — Discoverer Enterprise
WEST Job #3925**

Workscope Accomplished:

- The BOP stack was wellbore pressure tested to MWP using a 5" and 6-5/8" test joint. See Discussion.

Recommendations :

None.

Discussion :

The BOP stack and LMRP was wellbore pressure tested to MWP. The upper and middle HVR (Hydril Variable Rams) 4-1/2" x 7" were wellbore pressure tested to 200-300 psi for five minutes and 15,000 psi for five minutes using a 5" and 6-5/8" test joint. The rams were closed with 1,500 psi with the MPL engaged and then the rams were put in the block position to vent off the closing pressure. All tests were charted and acceptable. The failsafe valves were incorporated into the ram wellbore pressure testing. Before testing, the failsafe valves were opened with 1,500 psi and then the valves were put in the block position and closed on spring tension only and tested to 200-300 psi and 15,000 psi. The lower outer kill valve did not fully close on spring tension, therefore, it would not hold a pressure test. The valve operator will be removed and replaced with a spare valve operator.

The annular was wellbore pressure tested to MWP. The annular was closed with 1,500 psi. The annular was then pressure tested to 200-300 psi for five minutes and 10,000 psi for five minutes using a 5" and 6-5/8" test joint. All tests were charted and acceptable.

At the writing of this report, the upper blind shear rams are in the process of being pressure tested. The lower blind shear rams and the lower 9-5/8" pipe rams have not been tested. After being tested they will be reported in daily report #11.

All pressure tests were performed on the yellow pod SEM A. A proper test procedure with opening and closing times and gallon counts will be provided in daily report #11. Due to having to stop and repair several leaks on the H.P. test unit, pressure testing took longer than anticipated.

Projected Workscope :

1. Perform the EOW maintenance procedures on the BOP.
2. Perform an EDS in mode 1, mode 2 and mode 3 from the subsea shop panel, drillers panel and toolpushers panel.
3. Pressure test the BOP stack to MWP.
4. Pressure test the choke and kill manifold to MWP.
5. Verify ROV panel functionality from all stack mounted hot stabs.
6. While pressure testing the BOP stack, verify the pressure/temperature transducer mounted on the BOP stack is working properly.
7. Rebuild the 5K to 4K HP casing shear ram regulator.

Best Regards,

David Moore
WEST Technical Specialist

To: Paul.king1@deepwater.com ; discover@bp.com ;
stoltzd@bp.com ; lemairdw@bp.com ; trent.fleece@bp.com ;

Date: 9 May 2010gn

Copy: Greg Childs, WEST Engineering Services

From: David Moore—WEST Engineering Services

Page 1 of 2

FORM WES-OP-001 REV
09/2009

**Daily Report #11 — Discoverer Enterprise
WEST Job #3925**

Workscope Accomplished:

- Attended the rig fire and abandon ship drill.
- The upper and lower blind shear rams were wellbore pressure tested. Also the lower 9-5/8" casing rams were wellbore pressure tested. See Discussion.
- The BOP stack and control system was function tested on the blue pod.

Recommendations :

1. It is recommended that the ROV panels mounted on the BOP stack and LMRP are function and pressure tested.

Discussion :

The upper blind shear rams and lower blind shear rams were wellbore pressure tested. The BSRs were closed with 1,500 psi and the MPL engaged. Once the locks were engaged the 1,500 psi closing pressure was vented to 0 psi. The low pressure applied was 200-300 psi and the high pressure was 15,000 psi. The charts were reviewed and acceptable.

The lower 9-5/8" casing rams were wellbore pressure tested. A 9-5/8" test joint was lowered into the wellbore. The 9-5/8" casing rams were closed with 1,500 psi and the MPL engaged. Once the locks were engaged the 1,500 psi closing pressure was vented to 0 psi. The low pressure applied was 200-300 psi and the high pressure was 15,000 psi. The charts were reviewed and acceptable.

At the writing of this report the lower outer kill valve replacement operator was being pressure tested to 3,000 psi. Once pressure tested the operator will be installed on the lower outer kill valve body and wellbore pressure tested to 200-300 psi for five minutes and 15,000 psi for five minutes. The valve will be placed in the half-open position and tested to 15,000 psi.

All pressure tests were performed on the yellow pod. A proper test procedure with opening and closing times and gallon counts were recorded. See Attachment A.

WEST was informed that the ROV panels mounted on the BOP stack and the LMRP will be function and pressure tested.

WEST was informed tonight that a potential problem with the forward casing shear ram bonnet may exist. While working on the yellow pod, the subsea engineer noticed fluid leaking from the forward casing shear ram bonnet weep hole. No operating pressure was applied to the bonnet. On April 29th while performing an EDS the rod seals were leaking and had to be replaced. The rod seals were replaced and the bonnet was tested. No leaks were observed. The subsea engineer informed WEST that he has a call in to Hydril. His plan is to have Hydril come to the rig and investigate this issue.

Attachments:

A. BOP test procedure results.

Projected Workscope :

1. Perform the EOW maintenance procedures on the BOP.
3. Pressure test the lower outer kill failsafe valve to MWP.
4. Pressure test the choke and kill manifold to MWP.
5. Verify ROV panel functionality from all stack mounted hot stabs.
6. While pressure testing the BOP stack, verify the pressure/temperature transducer mounted on the BOP stack is working properly.
7. Rebuild the 5K to 4K HP casing shear ram regulator.
8. Investigate the leaking forward casing shear ram bonnet rod seal leak.

Best Regards,

David Moore
WEST Technical Specialist

Operator: BP
 Well Name: Surface test
 Rig Name: Discoverer Enterprise

Date of last pressure test: N/A
 Location of last pressure test: N/A
 Pod used on last pressure test: N/A

Current pressure test date: 05/08/10
 Current location of pressure test: Subsea
 Current pod used on pressure test: Yellow

Current function test date: 05/09/10
 Function test location blue pod: Subsea
 Function test location yellow pod: Subsea

Test plug landed: N/A
 Fluid used on test: N/A

- Test Procedure:**
- 1) UOK, LOK (topside) Down Kill
 - 2) ANN 6 5/8", IBV
 - 3) ANN 6 5/8", OBV
 - 4) UIK, LIK (topside)
 - 5) MVBR's 6 5/8", LIC
 - 6) UVBR's 6 5/8", LOC
 - 7) KILL ISO (topside)
 - 8) CHOKE ISO (topside) Down Chk
 - 9) OBV, UOC, LOC (topside)
 - 10) IBV, UIC, LIC (topside)
 - 11) LSR, UOK (UOC, UIC, LOC, LIC cavity)
 - 12) USR, UIC (UOK, UIK cavity) Down Kill
 - 13) USR, UOC (LOK, LIK cavity)
 - 14) LPR 9 5/8"
 - 15) MVBR's 5", LIK Down Chk
 - 16) UVBR's 5" LOK, UIK
 - 17) ANN 5" (OBV, IBV cavity test)

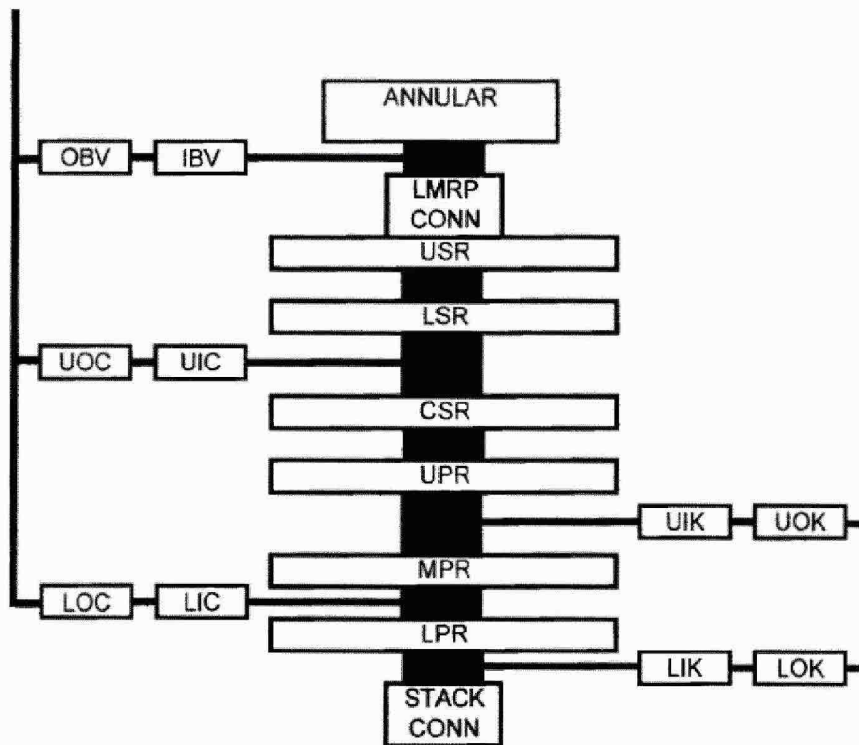

		Yellow Time	Gallons	Blue Time	Gallons	Pressure Low	High	Time Low	High
Annular Preventer	Close	:38	47.2	:27	44.1				
	Open	:39	48.8	:23	42.8				
Upper VBR's	Close	:20	22.2	:22	19.9	250	15000	5 Min	5 Min
	Open	:21	18.3	:22	17.1				
Middle VBR's	Close	:21	22.6	:21	20.0	250	15000	5 Min	5 Min
	Open	:20	18.1	:21	17.1				
Lower 9 5/8"	Close	:20	22.5	:19	20.4	250	15000	5 Min	5 Min
	Open	:23	19.0	:23	17.3				
Inner Bleed	Open	:5	0.9	:5	0.7				
	Close	:5	1.1	:5	1.5				
Outer Bleed	Open	:5	0.8	:5	0.7				
	Close	:5	1.1	:5	1.5				
Upper Inner Choke	Open	:5	0.9	:5	0.7	250	15000	5 Min	5 Min
	Close	:5	1.0	:5	0.9				
Upper Outer Choke	Open	:5	1.1	:5	0.7	250	15000	5 Min	5 Min
	Close	:5	0.7	:5	0.9				
Lower Inner Choke	Open	:5	1.0	:5	0.7	250	15000	5 Min	5 Min
	Close	:5	0.9	:5	0.9				
Lower Outer Choke	Open	:5	0.9	:5	0.7	250	15000	5 min	5 Min
	Close	:5	0.9	:5	1.1				
Upper Inner Kill	Open	:5	0.8	:5	0.7	250	15000	5 Min	5 Min
	Close	:5	1.2	:5	0.8				
Upper Outer Kill	Open	:5	0.8	:5	0.7	250	15000	5 Min	5 Min
	Close	:5	1.3	:5	0.8				
Lower Inner Kill	Open	:5	0.8	:5	0.7	250	15000	5 Min	5 Min
	Close	:5	0.9	:5	0.8				
Lower Outer Kill	Open	:5	0.7	:5	0.8	250	15000	5 Min	5 Min
	Close	:5	0.8	:5	0.7				

BEFORE YOU FUNCTION SHEAR RAMS CALL DRILLER AND ENSURE THERE IS NOTHING ACROSS THE BOPS.

SIGNATURE:

Upper Blind Shears	Close	:32	32.8	:38	30.3	250	15,000	5 Min	5 Min
	Open	:30	28.2	:34	27.7				
	HP Close	Functioned		Functioned					
Lower Blind Shears	Close	:37	43.4	:40	40.3	250	15,000	5 Min	5 Min
	Open	:35	40.5	:38	37.4				
	HP Close	Functioned		Functioned					
Casing Shears	Close	:41	45.4	:41	44.2	Function test only			
	Open	:38	42.6	:37	43.7				
	HP Close	Functioned		Functioned					

Operator: BP
 Well Name: NEW WELL
 Rig Name: Discoverer Enterprise

Date of last pressure test: N/A
 Location of last pressure test: N/A
 Pod used on last pressure test: N/A

Current pressure test date: 05/05/10
 Current location of pressure test: Surface
 Current pod used on pressure test: Yellow

Current function test date: 05/05/10
 Function test location blue pod: Subsea
 Function test location yellow pod: Subsea

Test plug landed: N/A
 Fluid used on test: H2O

Test Procedure:
 DOWN KILL
 1) Annular on 5", OBV
 2) Annular on 5", IBV
 3) Annular "U" seal, Boost Valve
 DOWN CHOKE
 4) Cavity Test bleed valves, Annular 5"

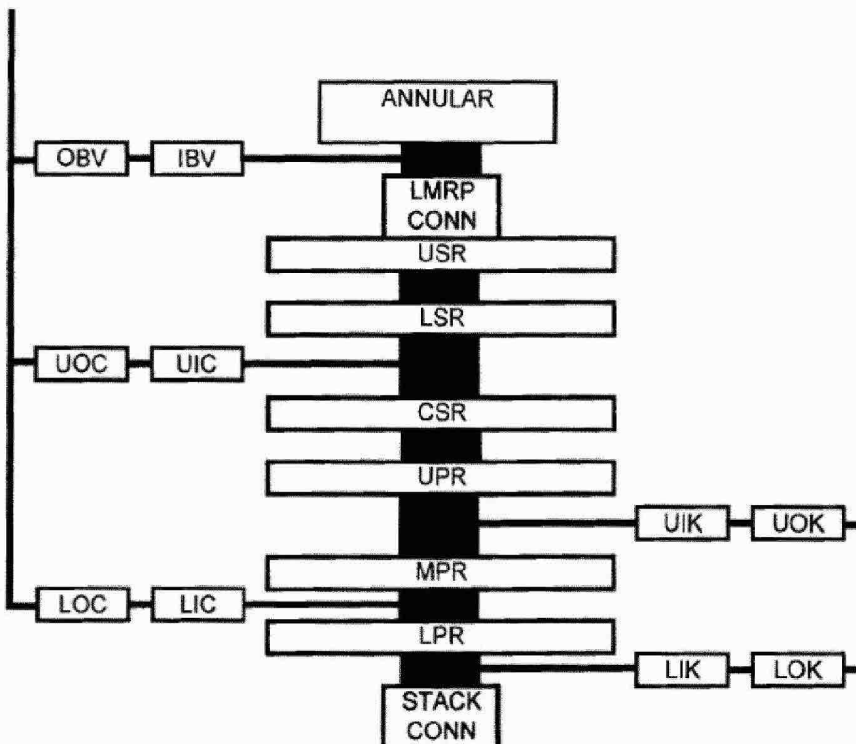

Attachment A

		Yellow		Blue		Pressure		Time	
		Time	Gallons	Time	Gallons	Low	High	Low	High
Annular Preventer	Close	:22	47.8	:21	43.6	250	10,000	5 Min	10 Min
	Open	:19	52.4	:19	44.8				
Upper VBR's	Close								
	Open								
Middle VBR's	Close								
	Open								
Lower 9 5/8"	Close								
	Open								
Inner Bleed	Open	:5	0.9			250	10,000	5 Min	10 Min
	Close	:5	1.2						
Outer Bleed	Open	:5	0.9			250	10,000	5 Min	10 Min
	Close	:5	1.0						
Upper Inner Choke	Open								
	Close								
Upper Outer Choke	Open								
	Close								
Lower Inner Choke	Open								
	Close								
Lower Outer Choke	Open								
	Close								
Upper Inner Kill	Open								
	Close								
Upper Outer Kill	Open								
	Close								
Lower Inner Kill	Open								
	Close								
Lower Outer Kill	Open								
	Close								

To: Paul.king1@deepwater.com ; discover@bp.com ; stoltzd@bp.com ; lemairdw@bp.com ; trent.fleece@bp.com ; Date: 10 May 2010
Copy: Greg Childs, WEST Engineering Services
From: David Moore–WEST Engineering Services gn Page 1 of 2

FORM WES-OP-001 REV
09/2009

**Daily Report #12 — Discoverer Enterprise
WEST Job #3925**

Workscope Accomplished:

- The lower outer kill failsafe valve operator was removed due to the valve not fully closing on spring tension only. The operator has not been disassembled but you can see inside the operator and see that the spring is broken. The rebuilt valve operator to be installed was pressure tested on the open and close side to 3,000 psi for five minutes each. Both tests were charted and acceptable. The operator is ready to be installed.
- The decision was made to prepare the LMRP to be run subsea. The BOP/LMRP was skid to well center in preparation to run the LMRP subsea. See Discussion.

Recommendations :

1. A Hydril service technician is to be dispatched to the rig and inspect the leaking forward casing shear ram bonnet rod seals. It is recommended that TOI ensure that a fleet spare bonnet and spare seals are available and can be sent to the rig if needed.

Discussion :

The riser connector was unlatched from the BOP. The BOP/LMRP was skid to well center in preparation to run the LMRP subsea. A double stand of riser was lowered through the rotary table and stabbed onto the LMRP riser adapter. The riser bolts were made-up to the riser adapter with 11,726 ft/lbs, Moly 503 was used as the lubricant. The LMRP was raised and the BOP stack was skidded back to the storage area. The LMRP was lowered to the moonpool level and captured in the spider beams to reduce movement. See Figure 12.1.

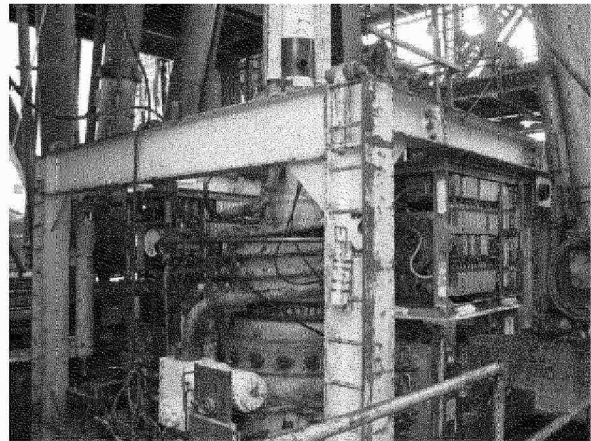

Figure 12.1: LMRP captured in the moonpool spider beams.

Two ROV operated ball valves were mounted near the bottom of the first riser joint and secured with straps. MUX cable clamps were installed on the first joint of riser and the MUX cables were secured within the clamps. See Figure 12.2.



Figure 12.2: ROV operated ball valves (red arrows) installed and MUX cables installed on the riser joint.

The subsea engineer talked to Hydril concerning the forward casing shear ram bonnet leak. Hydril said the problem sounds like a dimensional problem and will notify their service department about dispatching a service technician to the *Discoverer Enterprise*. The subsea engineer said that he would verify that if a fleet spare is available and can be readily sent to the rig if needed.

Attachments:

None.

Projected Workscope :

1. Perform the EOW maintenance procedures on the BOP.
2. Pressure test the lower outer kill failsafe valve to MWP.
3. Pressure test the choke/kill manifold to MWP.
4. Verify ROV panel functionality from all stack mounted hot stabs.
5. While pressure testing the BOP stack, verify the pressure/temperature transducer mounted on the BOP stack is working properly.
6. Rebuild the 5k to 4k HP casing shear ram regulator.
7. Hydril service technicians will be dispatched to the rig to inspect the leaking forward casing shear ram bonnet.

Best Regards,

David Moore
WEST Technical Specialist

To: Paul.king1@deepwater.com ; discover@bp.com ;
stoltzd@bp.com ; lemairdw@bp.com ; trent.fleece@bp.com ;

Date: 11 May 2010gn

Copy: Greg Childs, WEST Engineering Services

From: David Moore—WEST Engineering Services

Page 1 of 1

FORM WES-OP-001 REY
09/2009

**Daily Report #13 — Discoverer Enterprise
WEST Job #3925**

Workscope Accomplished:

- At approximately 0245 this morning the LMRP was run subsea. The rig continued to run riser throughout the day.
- WEST was informed by the subsea engineer that a spare casing shear ram bonnet could not be sourced. The rig has five spare seal kits for the casing shear ram bonnet onboard the rig.

Recommendations :

None.

Discussion :

WEST was asked by BP to write a report on the EDS and Deadman testing that was performed on the surface during this survey. This is in process. We were also requested to write a report on the surface wellbore testing of the BOP, ROV intervention testing and a review of the BOP maintenance plan to confirm it adheres to the OEM procedure and using OEM parts.

WEST will depart the rig tomorrow and possibly be returning Monday the 17th.

Projected Workscope :

1. Perform the EOW maintenance procedures on the BOP.
2. Pressure tested the lower outer kill failsafe valve to MWP.
3. Pressure tested the choke and kill manifold to MWP.
4. Verify ROV panel functionality from all stack mounted hot stabs.
5. While pressure testing the BOP stack, verify the pressure/temperature transducer mounted on the BOP stack is working properly.
6. Rebuild the 5K to 4K HP casing shear ram regulator.
7. Hydril service technicians will be dispatched to the rig to inspect the leaking forward casing shear ram bonnet.

Best Regards,

David Moore
WEST Technical Specialist

P.O. Box 577
Brookshire, Texas 77423
U.S.A



Tel: (281) 375-5515
Fax: (281) 934-1600
west@westengineer.com

ISO9001:2008 Certified

To: Paul.king1@deepwater.com ; discover@bp.com ;
stoltzd@bp.com ; lemairdw@bp.com ; trent.fleece@bp.com ;

Date: 12 May 2010gn

Copy: Greg Childs, WEST Engineering Services

From: David Moore—WEST Engineering Services

Page 1 of 1

FORM WES-OP-001 REV
09/2009

Daily Report #14 — *Discoverer Enterprise* WEST Job #3925

Workscope Accomplished:

- WEST departed the *Discoverer Enterprise* today and is standing by in a hotel in Houma, La.

Recommendations :

- None

Projected Workscope :

- Perform the EOW maintenance procedures on the BOP.
- Pressure test the lower outer kill failsafe valve to MWP.
- Pressure test the choke and kill manifold to MWP.
- Verify ROV panel functionality from all stack mounted hot stabs.
- While pressure testing the BOP stack, verify the pressure/temperature transducer mounted on the BOP stack is working properly.
- Rebuild the 5k to 4k HP casing shear ram regulator.
- Hydril service technicians will be dispatched to the rig to inspect the leaking forward casing shear ram bonnet.

Best Regards,

David Moore
WEST Technical Specialist

To: Paul.king1@deepwater.com ; discover@bp.com ;
stoltzd@bp.com ; lemairdw@bp.com ; trent.fleece@bp.com ;

Date: 13 May 2010

Copy: Greg Childs, WEST Engineering Services

From: David Moore—WEST Engineering Services

Page 1 of 1

FORM WES-OP-001 REY
09/2009

**Daily Report #15 — Discoverer Enterprise
WEST Job #3925**

Workscope Accomplished:

- WEST continues to stand-by in a hotel in Houma, La. WEST was requested to return to the rig tomorrow.

Recommendations :

None

Discussion :

Attachments:

None

Projected Workscope :

1. Perform the EOW maintenance procedures on the BOP.
2. Pressure test the lower outer kill failsafe valve to MWP.
3. Pressure test the choke and kill manifold to MWP.
4. Verify ROV panel functionality from all stack mounted hot stabs.
5. While pressure testing the BOP stack, verify the pressure/temperature transducer mounted on the BOP stack is working properly.
6. Rebuild the 5k to 4k HP casing shear ram regulator.
7. Hydril service technicians will be dispatched to the rig to inspect the leaking forward casing shear ram bonnet.

Best Regards,

David Moore
WEST Technical Specialist

To: Paul.king1@deepwater.com ; discover@bp.com ;
stoltzd@bp.com ; lemairdw@bp.com ; trent.fleece@bp.com ;

Date: 14 May 2010gn

Copy: Greg Childs, WEST Engineering Services

From: David Moore—WEST Engineering Services

Page 1 of 2

FORM WES-OP-001 REY
09/2009

**Daily Report #16 — *Discoverer Enterprise*
WEST Job #3925**

Workscope Accomplished:

- WEST arrived back onboard the *Discoverer Enterprise*.
- Discussed with the subsea engineer upcoming well control equipment work to be performed.

Recommendations :

None.

Discussion :

Discussed with the subsea engineer upcoming well control equipment work to be performed. A rebuilt casing shear ram bonnet was delivered to the rig. The bonnet operator will need to be pressure tested to 4,000 psi before the bonnet is installed on the body. Once installed the bonnet bolts will be torqued and a MWP test will be applied to ensure pressure integrity.

The rebuilt lower outer kill failsafe valve operator was installed on the body. The operator (open and close) was pressure tested to 3,000 psi for five minutes each before the operator was installed on the body. A 1,500 psi opening pressure will be applied to the operator and then the pressure bled off allowing the spring to close the valve. The valve gate will be wellbore pressure tested to 200-300 psi for five minutes and 15,000 psi for five minutes. The LOK and the casing shear ram bonnet seal can be tested simultaneously.

The ROV panels on the BOP stack are to be function tested. It is recommended that after the upper and lower blind shear rams are closed a MWP test be performed to ensure the rams are fully closed.

Rebuild the leaking 5K to 4KHP casing shear ram regulator.

Projected Workscope :

1. Perform the EOW maintenance procedures on the BOP.
2. Pressure test the lower outer kill failsafe valve to MWP.
3. Pressure test the choke and kill manifold to MWP.
4. Verify ROV panel functionality from all stack mounted hot stabs.
5. While pressure testing the BOP stack, verify the pressure/temperature transducer mounted on the BOP stack is working properly.
6. Rebuild the 5K to 4K HP casing shear ram regulator.
7. A rebuilt casing shear ram bonnet was delivered to the rig. The bonnet operator needs to be pressure tested to 4,000 psi before being installed. Once pressure tested, the bonnet will be installed, the bonnet bolts torqued and a MWP test performed to ensure pressure integrity.

Best Regards,

David Moore
WEST Technical Specialist

To: Paul.king1@deepwater.com ; discover@bp.com ;
stoltzd@bp.com ; lemairdw@bp.com ; trent.fleece@bp.com ;

Date: 15 May 2010gn

Copy: Greg Childs, WEST Engineering Services

From: David Moore—WEST Engineering Services

Page 1 of 3

FORM WES-OP-001 REY
09/2009

**Daily Report #17 — Discoverer Enterprise
WEST Job #3925**

Workscope Accomplished:

- The rebuilt casing shear ram bonnet operator (open and close) was pressure tested to 4,000 psi for five minutes each. See Discussion.
- The rebuilt casing shear ram bonnet was installed on the body.
- The workscope for tonight is to replace the forward casing shear ram operator bolts as per Hydril Advisory 09-001. See Discussion and Attachment A.

Recommendations :

None.

Discussion :

The rebuilt casing shear ram bonnet operator (open and close) was pressure tested to 4,000 psi for five minutes each before the bonnet was installed on the body. The bonnet was then installed on the forward casing shear ram body and bonnet bolts torqued to 2,000 ft/lbs.

The workscope for tonight is to replace the 16 each forward casing shear ram operator bolts as per Hydril Advisory 09-001. See Figure 17.1. and Attachment A. Once the new bolts are installed the bolts will be torqued to 1,700 ft/lbs using Moly 503 lubricant. The bolts are 1-1/2" x 5-1/2", Hex head, Xylan coated and Inconel 718 precipitation hardened.

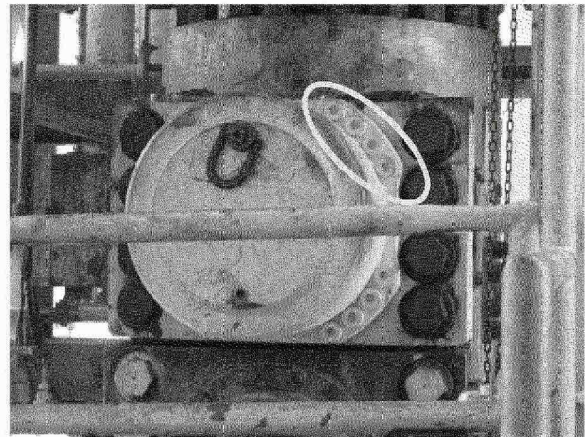

Figure 17.1 Casing shear ram operator bolts to be replaced.

Time permitting, the night subsea engineer will also complete the hosing of the wellhead connector and remove the 5K to 4K HP casing shear ram regulator and install a repair kit.

Attachments:

A. Hydril Advisory Notice 09-001

Projected Workscope :

1. Perform the EOW maintenance procedures on the BOP.
2. Pressure test the lower outer kill failsafe valve to MWP.
3. Pressure test the choke and kill manifold to MWP.
4. Verify ROV panel functionality from all stack mounted hot stabs.
5. While pressure testing the BOP stack, verify the pressure/temperature transducer mounted on the BOP stack is working properly.
6. Rebuild the 5K to 4K HP casing shear ram regulator.
7. A rebuilt casing shear ram bonnet was delivered to the rig. The bonnet operator needs to be pressure tested to 4,000 psi before being installed. Once pressure tested, the bonnet will be installed, the bonnet bolts torqued and a MWP test performed to ensure pressure integrity.

Best Regards,

David Moore
WEST Technical Specialist



IMPORTANT PRODUCT SAFETY NOTICE

YOUR IMMEDIATE ACTION IS REQUIRED

DATE: October 3, 2009

TO: All Users of Hydril 22" operators rated for 4000 psi working pressure on 18-3/4" - 15M Ram Blow-Out Preventers (BOPs).

NOTICE

Scope: GE Oil & Gas Drilling & Production has been notified of two instances on the same BOP in which a total of five bolts that attach the cylinder broke.

Problem: A detailed design review was performed and there is evidence that the assembly and maintenance procedures may have called for personnel to apply too high of a torque value to the fasteners. **IF THE BOLTS FAIL IN SERVICE, THE BOP MAY NOT CONTROL WELLBORE PRESSURE.**

This notice CONCERNS:

All bolts used to attach the cylinder to the bonnet on 22" Operators rated for 4000 psi working pressure. The bolts are part number 1931227-24044. These are 1 1/2" diameter bolts and are 5 1/2" long. These bolts are used in the following operator assemblies:

3136411, 3136411-01, 3136411-03, 3136411-04, 3137056, and 3137056-02.

ACTION REQUIRED:

GE Oil & Gas Drilling & Production recommends that all affected customers review their BOP stack configuration, operating conditions, and operations procedures in consideration of this advisory.

GE Oil & Gas Drilling and Production will be providing your company replacement bolts for those existing bolts in service and spare stocks. We request that all existing bolts (both installed and spares) be returned to GE Oil & Gas Drilling & Production. The new bolts will have a form of positive identification such that they are easily identified from the existing bolts. We are in the process of obtaining replacement bolts, revising procedures, and working with every customer affected, to affect the replacement process as soon as possible.

Thank you for being a GE Oil & Gas Drilling & Production customer. We appreciate your understanding and cooperation and assure you we will work with you to resolve this issue. If you have any questions, please call Customer Service at 281-449-2000.

Sincerely,

Bruce Pettey
Manager - Customer Service

To: Paul.king1@deepwater.com ; discover@bp.com ;
stoltzd@bp.com ; lemairdw@bp.com ; trent.fleece@bp.com ;

Date: 16 May 2010gn

Copy: Greg Childs, WEST Engineering Services

From: David Moore—WEST Engineering Services

Page 1 of 2

FORM WES-OP-001 REY
09/2009

**Daily Report #18 — *Discoverer Enterprise*
WEST Job #3925**

Workscope Accomplished:

- Started function testing the ROV control panels on the BOP stack. See Discussion.
- WEST departed the *Discoverer Enterprise* and boarded the Development Driller II.

Recommendations :

None

Discussion :

The subsea engineer started function testing the BOP stack ROV panels. The hot stab was connected to the upper blind shear rams and the blind shear rams were closed with 3,000 psi for five minutes. The test was charted and witnessed by WEST. The pressure was then bled to 0 psi. The lower outer kill failsafe valve was opened with 1,500 psi and the pressure was bled off and the valve closed on spring tension only. The lower inner kill failsafe valve was opened. At this time the LOK close and the forward casing shear ram bonnet was pressured to 200-300 psi for five minutes and 15,000 psi for five minutes. Both tests were charted and successful and witness by WEST.

The upper blind shear rams were opened with 1,500 psi. The ROV hot stab was connected to the lower blind shear rams and they were closed with 3,000 psi for five minutes, the test was charted and successful and witnessed by WEST. At this time WEST was asked to depart the rig and board the DD II.

WEST was informed that Hydril had sent out the wrong 5K to 4K regulator repair kit. The repair kit sent out was P/N 313444-RK, the correct repair kit P/N is 3137445-RK. The subsea engineer will contact Hydril and have the proper repair kit sent out.

Attachments:

None.

Projected Workscope :

1. Perform the EOW maintenance procedures on the BOP.
2. Pressure test the lower outer kill failsafe valve to MWP.
3. Pressure test the choke and kill manifold to MWP.
4. Verify ROV panel functionality from all stack mounted hot stabs.
5. While pressure testing the BOP stack, verify the pressure/temperature transducer mounted on the BOP stack is working properly.
6. Rebuild the 5K to 4K HP casing shear ram regulator.
7. A rebuilt casing shear ram bonnet was delivered to the rig. The bonnet operator needs to be pressure tested to 4,000 psi before being installed. Once pressure tested, the bonnet will be installed, the bonnet bolts torqued and a MWP test performed to ensure pressure integrity.

Best Regards,

David Moore
WEST Technical Specialist