

Report

Summary and Conclusions

Deepwater Horizon Incident

BP

 **add energy**

add wellflow as

7401
Exhibit No. _____
Worldwide Court Reporters, Inc.

CONFIDENTIAL

Summary and Conclusions Deepwater Horizon Incident

DATE: October 17, 2011	REVISION / REFERENCE ID: 0	PAGES: 22
CLIENT: BP		
CONTACT:		
DISTRIBUTION:		

ROLE:	NAME:	SIGNATURE:
Author	Morten H. Emilsen	<i>Morten Haug Emilsen</i>
Author		
Reviewer		

ABSTRACT:

This report is summarizing the key findings made during my work in the BP Internal Investigation Team. The report is prepared to highlight the results from my modeling work performed during the summer of 2010 and provide additional physical and other evidence that has been discovered since the time that my original report was completed. Reference is made to Appendix W of the Deepwater Horizon Accident Investigation Report issued by BP's internal investigation team September 8th 2010.

KEY WORDS:

Deepwater Horizon, Well Control

REPRODUCTION:

This report is created by **add wellflow as**, Norway. The report may not be altered or edited in any way or otherwise copied for public or private use without written permission from the author.



add energy

add wellflow as

Visiting address:
Strandveien 33
1366 Lysaker

Postal address:
Postboks 26
1324 Lysaker

tel +47 66 98 32 90

org. no. 962 238 742

addenergy.no

Table of Contents

SUMMARY	IV
1. BACKGROUND INFORMATION	5
1.1 Biography.....	5
1.2 add wellflow	5
1.3 OLGA Software and modeling	5
2. RESULTS	7
2.1 Simulations Performed and Considered	7
2.2 Key findings	7
2.3 Discussion of analysis	8
2.4 Additional evidence supporting the conclusions in the report	16
2.4.1 Static kill operation	16
2.4.2 Compressibility in the system after cementing	16
2.4.3 Integrity of seal assembly	16
2.4.4 Positive pressure test.....	16
2.4.5 Installation of lock-down sleeve.....	17
2.4.6 Relief well intersection	17
2.4.7 Schlumberger isolation scanner	17
2.4.8 Perforation of production casing.....	17
2.4.9 Confirmation that the drillpipe was bled	17
A. REFERENCES	18
B. CURRICULUM VITAE	19
C. MATERIALS CONSIDERED	21

Summary

On April 30, 2010, add wellflow was contacted and on May 1, 2010, I, Morten H. Emilsen, was retained by the BP Independent Investigation Team ("IIT") to use OLGA-WELL-KILL ("OWK") dynamic modeling simulations to analyze the situation that led to the explosion and fire that occurred on the Deepwater Horizon rig on April 20, 2010. My analysis and conclusions are set forth in Appendix W to the September 8, 2010 Deepwater Horizon Accident Investigation Report issued by BP's internal investigation team, which is incorporated in this Report.¹

I am submitting this Report to highlight the key findings from my modeling work performed during the Summer of 2010, as supplemented by additional physical and other evidence that has been discovered since the time that my original modeling and August 2010 report were completed.

The key findings from the work are:

- As outlined in my August 2010 report, the available evidence and simulation results strongly suggest that the initial flow path was through a leaking casing shoe and up through the inside of the casing, with flow starting at approximately 20:52. Physical evidence recovered after August 2010 and testimony provided since that date is consistent with my earlier modeling and confirms several assumptions made in the model.
- As outlined in my August 2010 report, simulations in combination with analysis of real time data suggest that the well became underbalanced at 20:52 hrs resulting in flow of hydrocarbons into the wellbore. Simulations showed a total gain of around 40 bbls taken between 20:52 hrs and 21:08 hrs and a cumulative amount of around 2000 barrels was taken up to the loss of realtime data at 21:49 hrs.

¹ Appendix W to the IIT Report is incorporated into this Report by reference and a copy is attached to this Report as Exhibit 1. For the purposes of clarity, I have used the same figure numbers in this Report as were used in Appendix W.

1. Background information

1.1 Biography

I am currently the VP Software & Technology at add wellflow. I have a Master's Degree in fluid mechanics and 20 years of experience in development and use of transient multiphase flow simulators. I developed the framework OLGA-WELL-KILL, tailor-made software for well control applications. I have experience from a number of well control incidents worldwide, including capping operations, bull-heading and relief well kill operations. I have supervised underbalanced drilling operations and planned dynamic kill operations. Further, my experience includes flow assurance and managing of larger field development projects, teaching and authoring of oil spill related publications.

I am being compensated for my work as an expert for BP in this litigation at the same rate that I am typically compensated by BP under the terms of add energy's Master Services Agreement with BP, as amended from time to time. At present, my daily rate under the structure set forth by that agreement is \$8,000 per day.

I have not previously testified as an expert in any litigation matters.

1.2 add wellflow

add wellflow was established in 1991 as Well Flow Dynamics and has since 2008 been a subsidiary of the add energy group. add wellflow provides drilling and production services and is recognized as a global leader in dynamic flow calculations for well control and contingency planning. The company's operations are designed to promote safety in connection with planning and implementation of drilling and well operations. add wellflow personnel act as advisors to operators during the planning and execution of well control emergency incidents. Typical well control projects include relief well drilling surface or subsea blowouts, shallow gas or water flow incidents, complex kick handling, dynamic kill of cross-flows, and snubbing and bullheading kill operations.

add wellflow as a company has been involved in more than 50 major blowout control projects, including offshore and onshore operations, relief well kill, deepwater operations, shallow gas flow, shallow water flow and cratered or broached blowouts. See www.addenergy.no for more information.

1.3 OLGA Software and modeling

For the dynamic simulations, OLGA-WELL-KILL (powered by OLGA from SPT Group) was applied. The model is a fully dynamic simulator that is capable of handling three different fluid phases simultaneously. The model is capable of handling non-Newtonian fluids; i.e. the viscosity is depending on the shear-rate. The OWK simulator handles a number of different flow configurations, e.g. annular flow, flow through bit nozzles, valves, pipe joints, etc. The original version of the OLGA-WELL-KILL model is described in a paper from 1996 [ref. 8]. Various application

of the model have been presented in a number of papers [ref. 1, 2, 3, 6, 9, 10 and 11].

The development of the base core OLGA started in 1979 at the Institute for Energy Technology (IFE). The initial development was financed by Statoil and the program was initially used to analyze practical problems for Statoil.

From 1983 until 1992 there were numerous multi-client projects where SINTEF was the project leader. SINTEF built the world's largest multiphase laboratory in Trondheim and conducted flow experiments, while IFE developed the source code. The code was jointly owned by SINTEF and IFE in the first multi-client projects including version OLGA89, released in 1989. After this, the sponsors took over the OLGA ownership.

In 1989, development of the Olga-Well-Kill started as a result of an underground blowout in the North Sea. The OLGA code was used as a basis to develop a software capable of simulating advanced well kill operations.

In 1993, the Norwegian company Scandpower (currently SPT Group) was awarded the right to commercialize OLGA. Since then the software has been under continuous and still ongoing development and supported by major oil companies. OLGA is today the leading transient multiphase flow simulator available to the industry.

The main limitation of the OLGA modelling is the accuracy of the input assumptions. Every effort was made to align the model inputs to ensure a match with the available recorded data and actual events as witnessed. Actual and reliable data for this well was used as input and this significantly improves the degree of accuracy of the model. The model results should reasonably reflect what actually occurred on April 20, 2010.

2. Results

2.1 Simulations Performed and Considered

Working with the BP independent investigation team ("IIT"), hundreds of flow simulations were performed in order to diagnose the situation and determine the events leading up to the incident. In my August 2010 report, I outline seven simulation cases based on various assumptions.

These simulation cases were based on witness accounts, real time data, well design, reservoir properties and reservoir fluid composition. The simulations included various combinations of assumptions about the conditions in the well, operations being conducted and the flow path of hydrocarbons.

Of these seven simulations, Case 7, which assumes that the BOP was closed at 21:41 but not sealed until 21:47, a net pay between 13 ft to 16.5 ft, and flow through the leaking casing shoe and up through the inside of the casing, was identified as the case that most closely matched the actual witness events and recorded data leading up to and during the accident.

Since my original report was issued on this flow path analysis in August 2010, I have become aware of and considered additional physical and testimonial/witness account evidence that has become available since that time to determine that this new evidence corroborates my original conclusions with respect to the most likely flow path.

2.2 Key findings

The flow path for the hydrocarbons was through a leaking casing shoe and up through the inside of the casing, with flow starting at approximately 20:52 hrs. Physical evidence discovered after August 2010 and testimony provided since that date is consistent with my earlier modelling and confirms several assumptions that were made in the model.

As outlined in my August 2010 report, the available evidence and simulation results strongly suggest that the initial flow path was through a leaking casing shoe and up through the inside of the casing. Using the input data collected by the BP IIT, it was not possible to simulate flow through the outer annulus of the casing and match the recorded data and actual events witnessed. It was also clear that key points of reference, such as a pressure increase during the sheen test could not be generated by flow through the outer annulus of the casing. The simulation shows a pressure decrease during this period of time rather than a pressure increase.

By using a net pay of between 13 ft and 16.5 ft at the base of the well and assuming flow via the casing shoe and through the production casing, a good simulation match for most of the actual events witnessed and data recorded can be achieved.

The simulation indicates that the well became underbalanced at 20:52 hrs, and flowed continuously through the production casing from 20:52 hrs through the loss of data transmission at 21:49 hrs.

Simulations showed that a total gain of around 40 bbls was taken between 20:52 hrs and 21:08 hrs. Further the simulations show a gain of 300 bbls by 21:30 hrs. When the annular preventer was activated at approximately 21:41, a total of 1000 bbls were taken. By 21:49 hrs, when the data transmission ends, the model estimated the gain to be approximately 2000 bbls. See Figure 18 below.

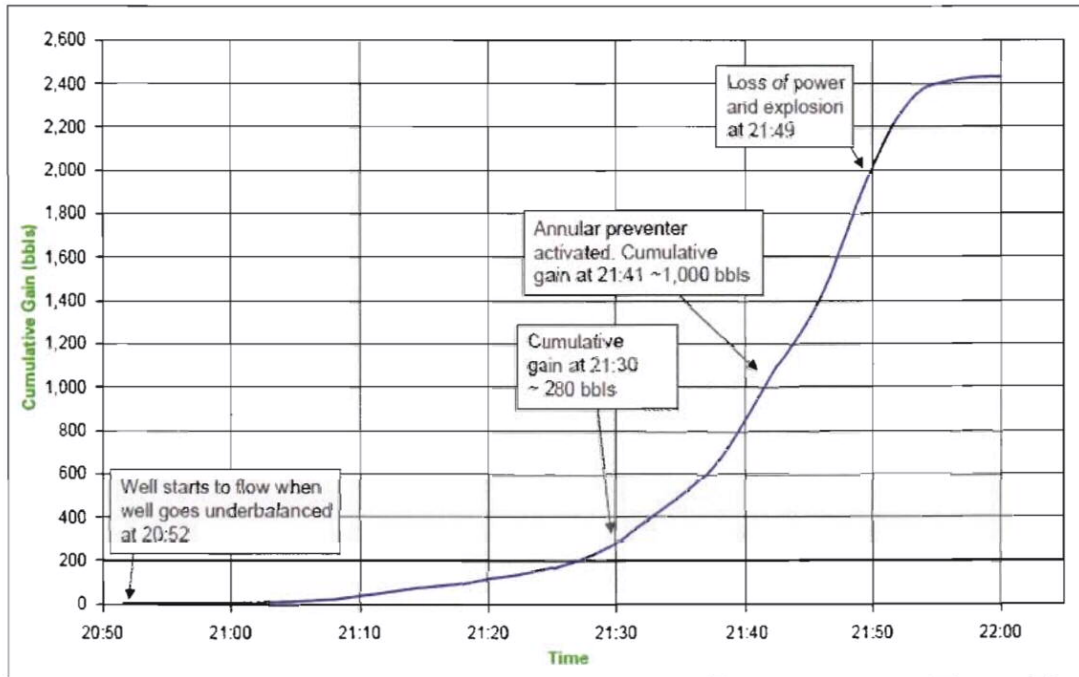

Figure 18. OLGA® Well Flow Modeling Prediction of Cumulative Gain Excluding Pumped Volumes 20:52 Hours–21:49 Hours.

Since my original report and work was completed in August 2010, physical evidence and additional testimony has confirmed the flow path strongly suggested by the OLGA modelling, and confirmed several assumptions that were made in the original work.

2.3 Discussion of analysis

The evaluations and findings made during this work were based on witness accounts, mud-logging data, cement unit data, well design, reservoir properties and reservoir fluid composition. Using the available input data, I built a detailed dynamic OWK network model, and used that model to analyze and understand the transients occurring in the wellbore right before the explosion.

The model includes the casing, the drill pipe, the boost line, the outer annulus, the riser, the surface piping, the mud-gas separator, pumps, valves and control systems. The fluids include seawater, 16 ppg high viscosity spacer (a combination of Form-A-Set and Form-A-Squeeze), 14 ppg mud and hydrocarbons.

The start time of the simulation is 15:00 hrs on April 20, 2010, when the entire wellbore was filled with 14 ppg mud. The simulations were performed following the operations for the entire period between 15:00 hrs and 21:49 hrs on April 20, 2010.

The following timeline provides the operations that took place between 15:00 hrs and 21.49 hrs on April 20, as well as a discussion of how the various simulations considered in my analysis fared as against the known evidence relating to those operations and times.

16:54. During the negative test, the reported gains (60-85 bbls) were higher than what could be expected due to the compressibility of the mud. Some of this discrepancy (50-60 bbls) was explained by a leaking BOP annular and some can be explained by the compressibility of the mud. When witness accounts became available to the IIT, it became evident that the assumed gain of 60 to 85 bbls during the negative test was primarily accounted for by a leaking BOP annular. The riser is believed to have been topped up with 50-60 bbls during this period due to the leaking BOP annular. Hence, no or only a small influx (0-22 bbls) was taken during the bleed downs during the negative test.

20:52. According to the simulations, the well became underbalanced at 20:52 hrs, resulting in flow of hydrocarbons into the wellbore. Simulations show a total gain of around 40 bbls taken between 20:52 hrs and 21:08 hrs, a result supported by the gains calculated from recorded mud pit data. By using a net pay of between 13 ft and 16.5 ft and assuming flow via the casing shoe and through the production casing, a good simulation match for most of the actual events witnessed and data recorded can be achieved. Using a net pay of between 13 and 16.5 feet also seems realistic; it is less than one fifth of the total productive sands in the well.

21:08. At 21:08 hrs a sheen test was performed to verify that all the mud was displaced and the spacer had reached the surface. Between 21:08 hrs and 21:14 hrs, when the mud pumps were shut down, the pressure on the drill pipe increased by more than 200 psi. This pressure increase could not be modeled by assuming flow through the outer annulus of the production casing; simulating flow in the outer annulus showed a decrease in pressure during this period rather than a pressure increase, as shown in the real time data. The 200 psi pressure increase seen in the real time data could be modeled by assuming flow through the production casing shoe. OLGA modeling calculated that in-flow to the well during this period was approximately 9 bbls/min.

21:10. At approximately 21:10 hrs during the sheen test, the flow was then routed to an overboard line bypassing the flow meters. From this point forward the flow from the well would have continued, but it appears that it went undetected by the rig crew.

21:14. At 21:14 hrs the mud pumps were restarted to displace the riser fully to seawater. This pumping operation continued until 21:30 hrs. The well would have continued to flow due to a significant amount of hydrocarbons already being in the wellbore causing a high underbalance with the reservoir pressure.

21:31. At 21:31 hrs, the real time data shows the rig pumps were shut down. After the pumps had been shut down, there was a pressure increase in the well. This can be explained either by a mechanical closure down hole or the hydrostatic effect of mud flowing up the casing/drill pipe annulus. There is no indication that the rig crew had taken actions to close the BOP at that stage. It is therefore thought that this first pressure increase was probably created by hydrostatic effects in the well rather than mechanical restrictions. OLGA modeling suggests that hydrocarbons had been continuously flowing into the well since 20:52 hrs and that a 300 bbl gain had been taken by 21:31 hrs.

21:36 to 21:38. There was a pressure transient event between 21:36 hrs and 21:38 hrs with a very rapid pressure drop and then increase of over 1000 psi. Simulations suggest that this was probably caused by bleeding off the drill pipe at surface. When trying to simulate this effect mechanically at the BOP by instantaneous opening and closing of a BOP element, the pressure transient effect created a much slower pressure response than was actually recorded during the event. The recorded sharp pressure response could be simulated by bleeding off the drill pipe pressure at surface. Witness accounts made available subsequent to my initial modeling confirm that a Transocean floorhand bled off the drill pipe at 21:36.

21:38. Simulations show that hydrocarbons passed from the well into the riser at approximately 21:38 hrs.

21:41 to 21:46. The pressure increase during the last eight minutes was likely due to the actions taken by the crew to close the BOP starting at approximately 21:41 hrs. Simulations indicate a more rapid increase in drill pipe pressure would have resulted if the well was shut-in and sealed at this time. The recorded data shows, however, that this rapid pressure increase did not happen until 21:47 hrs. It is possible that the crew closed one of the annular preventers at 21:41 hrs, but that it failed to seal. Other evidence that supports this theory includes:

- Witness accounts indicate that well control action was not taken until about 21:41 hrs
- There were erosion marks on the retrieved drill pipe suggesting high velocity flow through an annular
- The simulations show that to create the recorded pressure response a BOP element would need to be almost fully closed (about 99% closure)
- According to the simulations, if the annular preventer had not been closed, the drill pipe pressure would have dropped to 0 psi by 21:43 hrs as the remainder of the mud was ejected from the wellbore. However, because the drill pipe pressure only decreased to approximately 300 psi and then started to increase again, activation of an annular preventer likely occurred at 21:41 hrs and took approximately 45 seconds to close.

21:46. Gas arrives at surface at about 21:46 hrs and rapidly increases in rate to above 160 mmscfd. (See Figure 3.34, which shows the surface flow rates for Case 7.) The arrival time supports the possibility of gas alarms going off about this time and the explosion occurring at about 21:49 hrs.

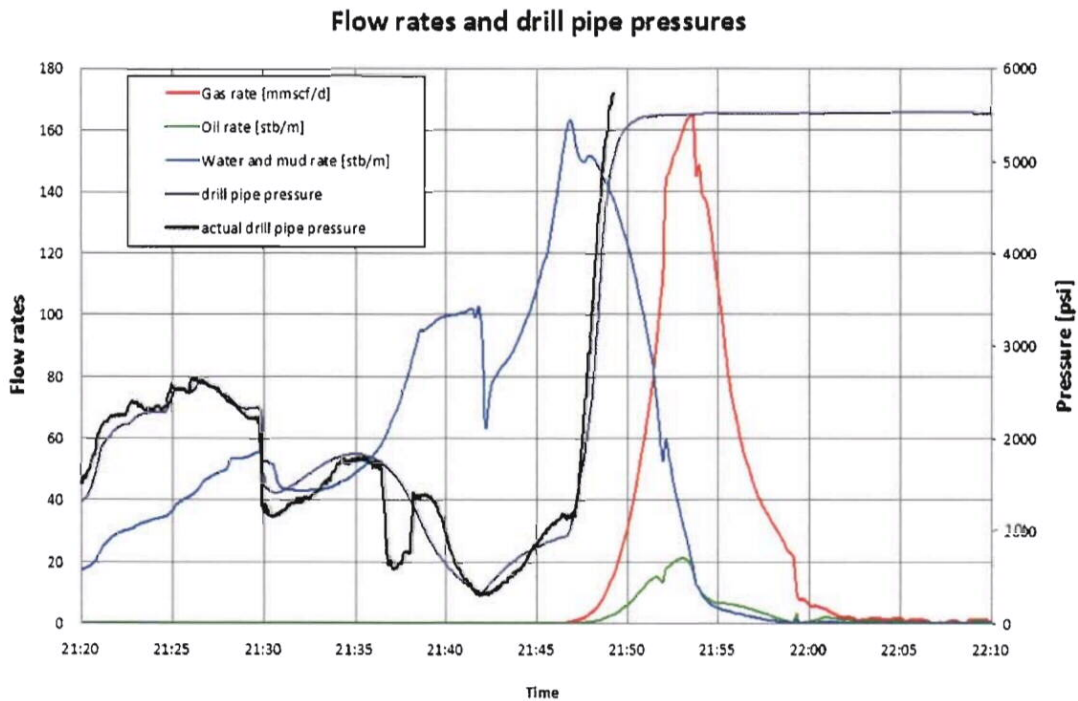

Figure 3.34: Case 7 - Flow and pressure at surface with closing annular from 21:41 hrs (not accounting for the surface bleed).

21:47. At 21:47 hrs the rapid pressure increase in the drill pipe could be simulated by a BOP element fully sealing the well.

21:49. The last actual pressure recording on the drill pipe was 5730 psi. According to the simulations, this pressure corresponds to a shut-in pressure with hydrocarbons in the wellbore up to the BOP and the drill pipe full of seawater.

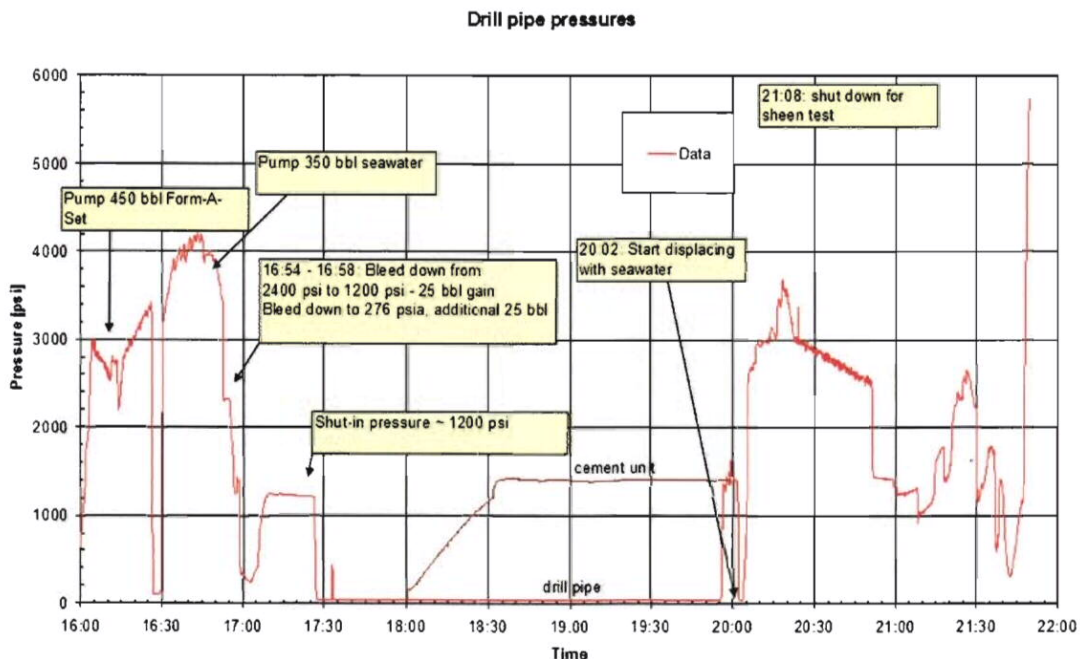

Figure 2.1: Recorded drill pipe pressures from 16:00 hrs to 21:49 hrs

Case 7, the final simulation assumed a lower volume of hydrocarbon influx was taken prior to 21:30 hrs, 13 feet of net pay, was the best match to the evidence and actual data in the case. The Case 7 simulation assumes that when the pumps are shut down at 21:30 hrs the pressure drops, creating a higher drawdown on the reservoir and from this point forward 16.5 feet of net pay.

By slowing down the hydrocarbon influx rate there is still 14 ppg mud below the bottom of the drill pipe in the production casing at 21:30 hrs. When the mud pumps are shutdown at 21:30 hrs, the mud flows past the tail of the drill pipe replacing the lighter seawater/mud mix with 14 ppg mud. This results in an increasing drill pipe pressure due to the increasing average density above the tail of the drill pipe (see Figure 3.32).

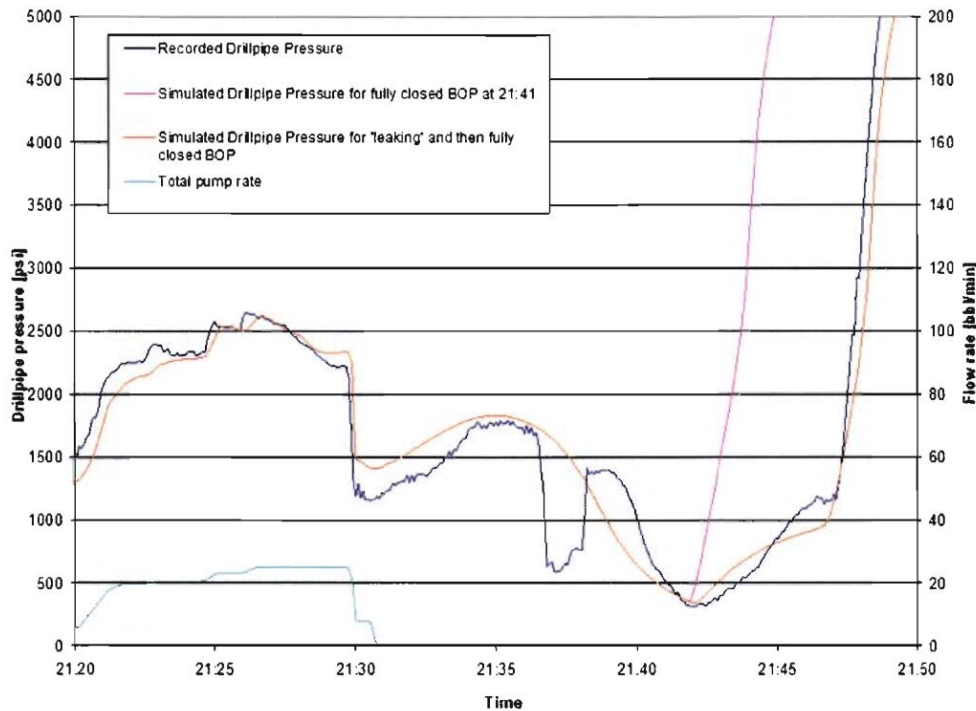

Figure 3.32: Case 7 - Pressure response for simulations with closing annular from 21:41 hrs (not accounting for the surface bleed).

The second increase at 21:43 hrs cannot be explained by a similar effect; by 21:42 hrs all of the mud is above the tail of the drill pipe and it is being replaced by lighter hydrocarbons. This would cause a further pressure drop and not the increase in pressure recorded (see Figure 3.31). For that reason, we have only been able to explain the increase in pressure at 21:42 hrs by assuming a closed but leaking BOP annular (see Figure 3.32).

As a point of confirmation, Figure 3.32 also shows the drill pipe pressure response if the BOP annular fully sealed; a much higher pressure increase is shown than what was recorded. The assumption of a leaking BOP annular is also supported by erosion seen on the recovered drill pipe.

At 21:47 hrs it is assumed that a BOP element fully seals the well. The modeled shut-in pressure closely matches the recorded pressure (see Figure 3.32).

Figure 3.33 show the cumulative influx of hydrocarbons and the influx rate in stb/m for Case 7.

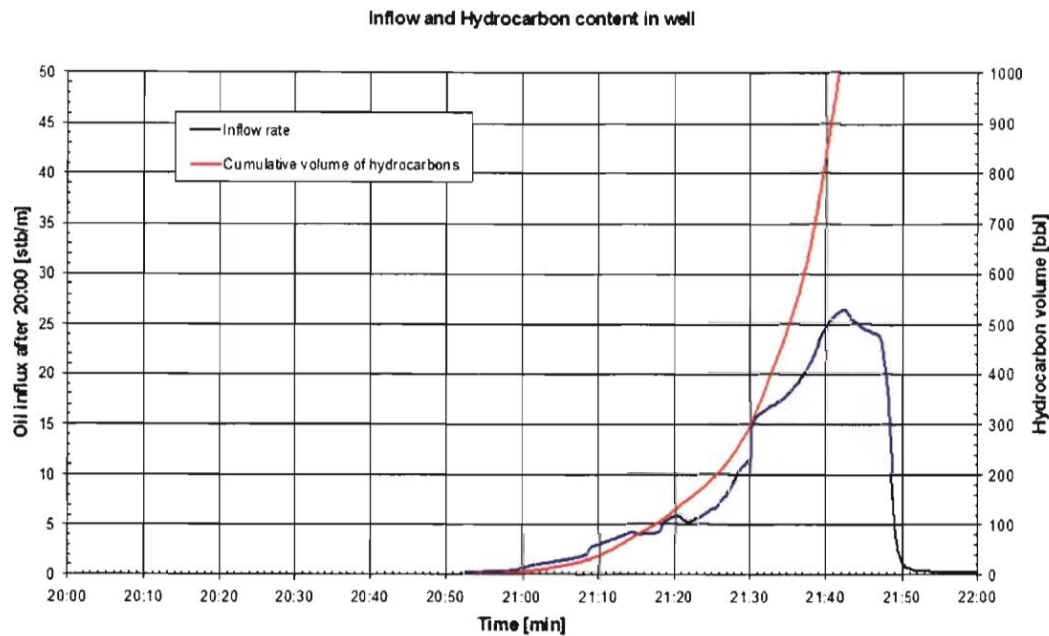

Figure 3.33: Case 7 - Inflow and hydrocarbon volume with closing annular from 21:41 hrs (not accounting for the surface bleed).

Figure 3.34 shows the surface flow rates for Case 7. Gas arrives at surface at about 21:46 hrs and rapidly increases in rate to above 160 mmscfd. The arrival time supports the possibility of gas alarms going off about this time and the explosion occurring at about 21:49 hrs.

Figure 3.35 shows the pressures above and below the BOP for Case 7.

The nature of the transient pressure signature during the last minutes before the BOP finally seals at 21:47 hrs is challenging to determine due to several factors. The exact location of the fluid fronts will affect the observed pressure fluctuations and these will again be affected by the reservoir inflow. In the simulations, fixed net pay has been used, but in reality, this property can change with changing downhole conditions. It is possible that initially, only small channels in the cement were open between reservoir and the wellbore. Later, as the drawdown increases, more of the reservoir could be exposed and hence increase productivity.

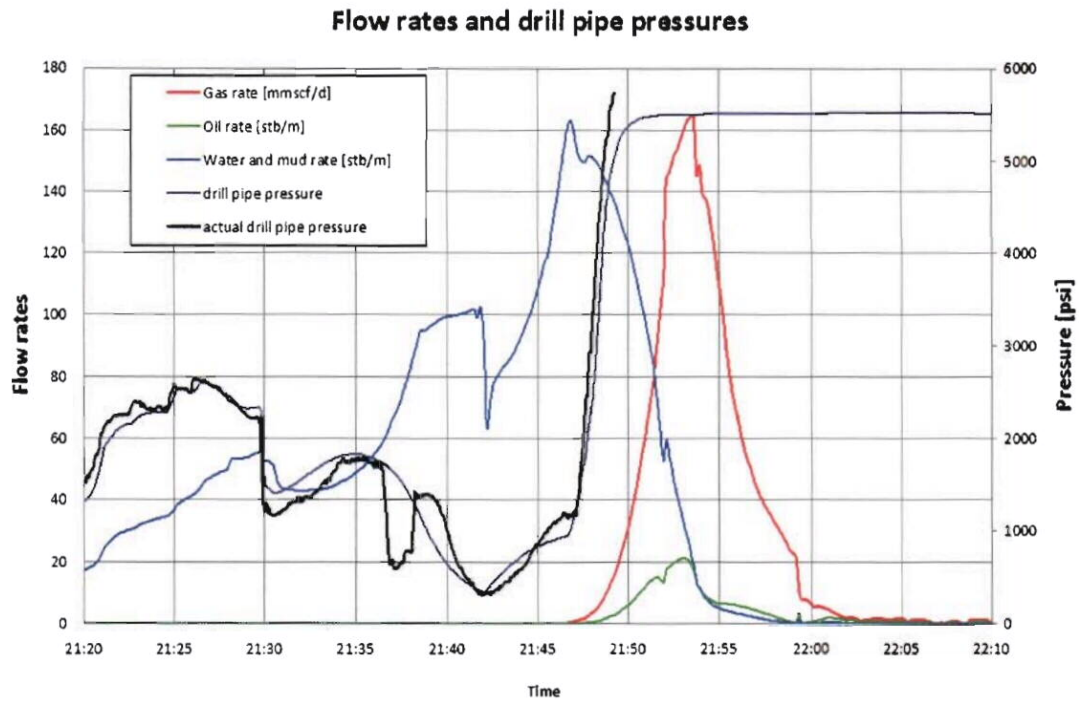

Figure 3.34: Case 7 - Flow and pressure at surface with closing annular from 21:41 hrs (not accounting for the surface bleed).

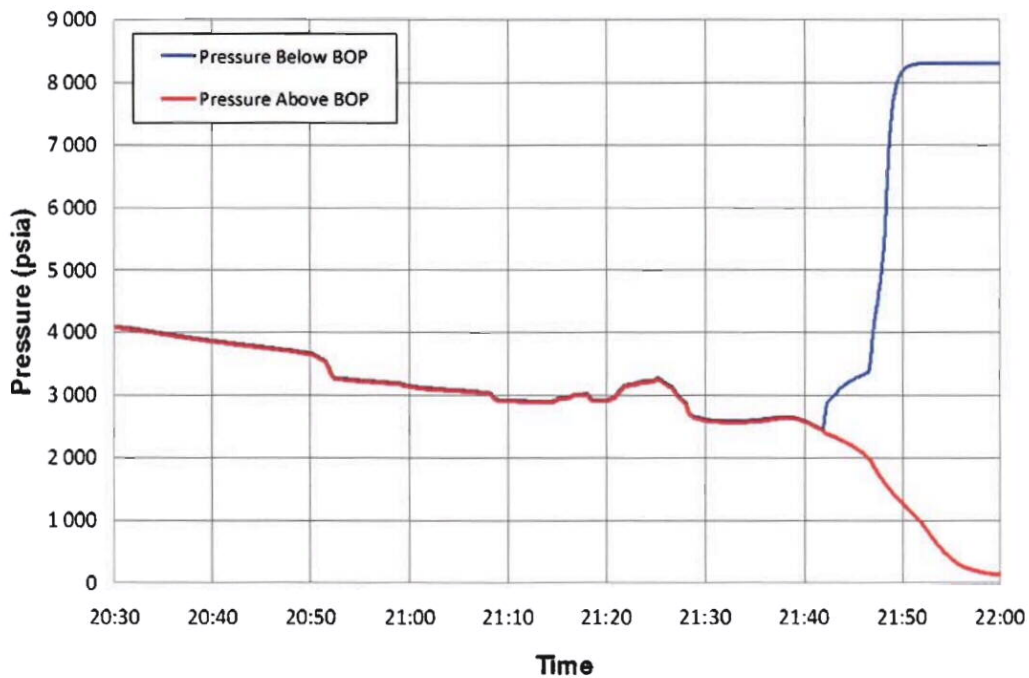

Figure 3.35: Case 7 - Pressure below and above the BOP when closing annular from 21:41 hrs (not accounting for the surface bleed).

2.4 Additional evidence supporting the conclusions in the report

The following lists some additional evidence supporting the conclusions drawn in my August 2010 report. Several of these evidences indicate that no hydrocarbons were present in the annulus. This is an indication of integrity of the cement above the producing reservoirs in the annulus. If the cap cement had failed, hydrocarbons would have migrated up through the annulus due to density difference and buoyancy.

2.4.1 Static kill operation

On August 3, 2010, a static kill operation (bullheading operation) was performed to displace the hydrocarbons in the wellbore with 13.2 ppg mud. Prior to the operation, simulations were performed that predicted the decline in pump pressure with time for various flow paths. The flow paths evaluated were flow in annulus, flow inside casing and flow through both the annulus and the casing. These simulations resulted in different pressure decline curves. Comparison with the actual operational data strongly supported the conclusion of flow inside the casing.

2.4.2 Compressibility in the system after cementing

A pressure test was performed after the cementing of the wellbore on August 5, 2010. The system was pressured up with the 13.2 ppg mud on top of the cement. The result indicated that only the casing was connected and not the annulus.

2.4.3 Integrity of seal assembly

On September 9, 2010, Dril-Quip Inc. used a lead impression tool to take an impression of the hanger and seal assembly. This lead impression showed that the 9 $\frac{7}{8}$ " hanger and seal assembly remained properly seated in the 18 $\frac{3}{4}$ " high pressure housing, where it had been placed on April 19, 2010, prior to the blowout. (See DDII IADC Report, 9/11/10 (TRN-USCG_MMS-00043342).)

On October 13, 2010, BP recovered the production casing hanger and seal assembly from the MC-252 #1 wellhead. Neither piece of equipment showed any signs of damage or erosion where annular flow would have caused serious erosion. Those areas were not damaged. This evidence supports the conclusion in my August 2010 report with respect to the flowpath being inside the casing and not through the annulus and seal assembly.

2.4.4 Positive pressure test

On September 10, 2010, a positive pressure test of the 9 $\frac{7}{8}$ " production casing in the well was performed. The test examined the pressure integrity of the casing hanger and seal assembly for a sustained period of time and reached an instantaneous shut-in casing pressure (ISICP) of 4270 psi. The kill line was shut in and, after 30 minutes, the shut-in pressure remained at 4158 psi. If the casing hanger had lifted up or the seal assembly had leaked, a decrease in pressure would be expected rather than a constant pressure.

2.4.5 Installation of lock-down sleeve

On September 11, 2010, following installation of the lock-down sleeve, it was pressure tested to 5200 psi, which indicated that the well hanger was properly seated because otherwise, annular flow would have lifted the hanger. This evidence indicates that the flow path was through the casing.

2.4.6 Relief well intersection

On September 16, 2010, the relief well intersected the MC-252 #1 in the annulus below the 9 $\frac{7}{8}$ " liner and performed bottoms up circulation. Full returns of drilling mud were observed at the DD3 with no signs of hydrocarbons. The pressure response during intersection indicated mud in the annulus. This strongly supports that the flow path was from the reservoir and down through the casing shoe.

2.4.7 Schlumberger isolation scanner

On September 22, 2010, Schlumberger used an isolation scanner tool to log the characteristics of fluid in the annulus between the mud line and 9318 ft MD. (DDII IADC Report 9/22/10 - TRN-USCG_MMS-00043388.) Based on the logging data, Schlumberger determined that free gas was not present in the annulus below the BOP.

2.4.8 Perforation of production casing

On October 7, 2010, the 9 $\frac{7}{8}$ " production casing was perforated between 9176 ft and 9186 ft to monitor pressure and returns. (DDII IADC Report 10/7/10 (TRN-USCG_MMS-00043449).) The drilling mud in the interior of the casing at the time was approximately 14.3 ppg synthetic-based mud ("SBM"). Hydrocarbons, if present in the annulus, would have exhibited a much lower density. There was no observed u-tube.

2.4.9 Confirmation that the drillpipe was bled

Notes from the Transocean investigation team's May 28, 2010 interview with Caleb Holloway, June 1, 2010 interview with David Young and June 4, 2010 interview with Wyman Wheeler, as well as the Chief Counsel's Report of the National Commission on the BP Deepwater Horizon Oil Spill and Offshore Drilling at 180 (referring to an interview with Caleb Holloway), confirm the assumption that the drillpipe was bled between 21:36 hrs and 21:38 hrs. The pressure response from the real time data could only be matched by assuming a bleed down through the drillpipe due to the shape of the response. This action would not be consistent with a rig crew responding to a recognized well control condition and the confirmation of this operation supports the modeling and simulation results.

A. References

1. Oskarsen, Wright, Rygg, Selbekk & Allcorn: "A Case Study in Relief-Well Drilling Using a Modified Driller's Method as a Well-Intervention Alternative to Bullheading." IADC Well Control Middle East 2008 Conference & Exhibition, 2-3 December 2008, Muscat, Oman
2. Rygg, O.B.: "Well control evaluation as an integral part of well design." IADC Well Control Conference Europe, Amsterdam 9-10 April 2008.
3. Rygg, O.B.: "The necessity of modelling in contingency planning and emergency well control response." IADC International Well Control Conference & Exhibition, Singapore 8-9 November 2005.
4. Reed, M., Emilsen, M. H., Hetland, B. Johansen, Ø, Buffington, S., "Numerical Model for Estimation of Pipeline Oil Spill Volumes", 2003 International Oil Spill Conference, Vancouver, British Columbia, Canada
5. Rygg, O, Emilsen, M. H., "Analysis Of The Hazardous Consequences Of Pipeline Ruptures", PSIG Annual Meeting, October 23-25, 2002, Portland, Oregon
6. Hartmann, R., Møllerstad, H., Bysveen, J. and Rygg, O.B. "Blowout Contingency for Deep Water High Rate Subsea Gas Wells" IADC International Deepwater Drilling Conference, Rio de Janeiro, Brazil, Nov. 2003
7. Holand, Per, "*Offshore Blowouts, Causes and Control*", Gulf Publishing Company, Houston Texas, 1997.
8. Rygg, O.B. Friedemann, J.D. and Nossen, J., "Advanced well flow model used for production, drilling and well control applications." IADC Well Control Conference for Europe, Aberdeen, May 1996
9. Rygg, O.B. and Smestad, P., "Blowout Control Hydraulics applied to Critical well Planning." IADC Well Control Conference for Europe, Stavanger, June 1994
10. Smestad, P., O.B. Rygg and J.W. Wright, "Blowout control: response, intervention and management, Part 5, Hydraulics modelling," World Oil, pp 75-80, April 1994
11. Rygg, O.B.; Smestad, P, and Wright, J.W.: "Dynamic Two-Phase Flow Simulator, a Powerful Tool for Blowout and Relief Well Kill Analysis." SPE 24578, Presented at the 67th SPE Annual Technical Conference and Exhibition, Washington DC, Oct. 1992.
12. Bendiksen, K., Malnes, D., Moe, R. and Nuland, S.: "The Dynamic Two-Fluid Model OLGA: Theory and Application." SPE Production Engineering, May 1991.

B. Curriculum Vitae

Name: Morten Haug Emilsen
Address: Bregneveien 23 B, 0875 OSLO
Date of birth: 9th July 1971, Bergen, Norway
Nationality: Norwegian
Languages: Norwegian and English
Profession: M.Sc., VP Technology & Software

Education:
1990 – 1994 NORWEGIAN INSTITUTE OF TECHNOLOGY, TRONDHEIM (NTH),
Fluid Dynamics and Hydrate Control. Use of the OLGA simulator.
Thesis: "Multiphase flow and Hydrate Control Effectivity, environment,
equipment and cost optimisation".

**Main field of
competence:**

Morten Haug Emilsen has a Master's Degree in fluid mechanics and 20 years of experience in development and use of transient multiphase flow simulators. As a partner of Well Flow Dynamics, a company specializing in well control and contingency planning, he developed the Olga-Well-Kill software. In addition he has also developed a number of other software applications, both internal and commercial software within multiphase flow. He has experience from a number of well control incidents world-wide, including capping operations, bull-heading and relief well kill operations. He has supervised underbalanced drilling operations and planned dynamic kill operations. Further, his experience includes flow assurance and managing of larger field development projects, teaching and authoring of oil spill related publications.

Experience:

2010 - add wellflow, VP Software & Technology
2008 - Well Flow Dynamics acquired by add energy group
2002 - 2008 Well Flow Dynamics. Vice President. Heading software development.
Blowout Control Advisor. Experience from a number of world-wide well control incidents (Europe, Middle East, US, Africa and Asia). In addition he has developed a number of Contingency Plans and been responsible for flow assurance projects. Software development, both internal and for clients.

1997 - 2002 Well Flow Dynamics. Senior Engineer. Blowout Control Advisor, Dynamic multiphase flow simulations. Involved in several critical well operations and blowouts world-wide. Developed several Contingency Plans for oil companies. Consultant (flow assurance and concept studies) for SAGA Petroleum ASA, Haltenbanken South Development. Consultant for STATOIL, Åsgard field Development (flow assurance).

Software Development: Participation in the merger between OLGA-WELL-KILL and OLGA2000. In charge of an extensive software development project for MMS in cooperation with Sintef. Developed the POSVCM (Pipeline Oil Spill Volume Computer Model), a transient pipeline leak/rupture model. Developed the steady state well flow simulator Wellflow™. Responsible for DEPOSIM™ GUI development.

1995 - 1997 Aker Engineering, Åsgard Field Development, STATOIL. Worked with the "Technical Total Concept Group". Evaluation of field development concepts. Dynamic multiphase flow simulations. Start-up and shutdown philosophy, normal operation, pipeline sizing. Responsible for Hydrate control in the Midgard wells and flowlines.

1994 Thesis at Aker Engineering, Aker Brygge, OSLO. Extensive use of the OLGA simulator. Flow assurance and hydrate control.

1993 Use of OLGA simulator (flow assurance and hydrate control) on a Statoil satellite field. NTH Project performed in Statoil's offices in Trondheim.

Professional memberships:

Board member of Society of Petroleum Engineers, OSLO Section, 1998 - 2007.

Publications:

Rygg, O, Emilsen, M. H., "Analysis Of The Hazardous Consequences Of Pipeline Ruptures", PSIG Annual Meeting, October 23-25, 2002, Portland, Oregon

Reed, M., Emilsen, M. H., Hetland, B. Johansen, Ø, Buffington, S., "Numerical Model for Estimation of Pipeline Oil Spill Volumes", 2003 International Oil Spill Conference, Vancouver, British Columbia, Canada

C. Materials considered

Investigation Reports

September 2010 BP Deepwater Horizon Incident Investigation Report (including appendices, presentations, animations and executive summary)

June 2011 Transocean Investigation Report Vols. 1 & 2

February 2011 Presidential Commission Chief Counsel's Report (PSC-MDL2179-002192-002562)

January 2011 Presidential Commission Report

MDL 2179 Deposition Transcripts & Exhibits

Ambrose, Billy Dean
Corser, Kent
Cowie, James
Dupree, James H.
Gisclair, John
Little, Ian
Mazella, Mark
Roth, Thomas
Sprague, Jonathan
Tooms, Paul
Vargo, Richard
Wells, James Kent

MDL Deposition Exhibits

MDL Dep Ex. 0911
MDL Dep Ex. 0912
MDL Dep Ex. 0913
MDL Dep Ex. 0914
MDL Dep Ex. 0915

Other Documents

BP-HZN-2179MDL00572747
BP-HZN-2179MDL00572754
BP-HZN-2179MDL00572758
BP-HZN-2179MDL00572762
BP-HZN-2179MDL00572771
BP-HZN-2179MDL00572786
BP-HZN-2179MDL00572813
BP-HZN-2179MDL00572828
BP-HZN-2179MDL00572847
TRN-USCG-MMS-00043342
TRN-USCG-MMS-00043388
TRN-USCG-MMS-00043449
TRN-INV-00001930
TRN-INV-00001936
TRN-INV-00004991
TRN-INV-00004998

APPENDIX

Appendix W. Report–Dynamic
Simulations Deepwater Horizon
Incident BP
(from ae add energy)

Report

Dynamic Simulations

Deepwater Horizon Incident

BP

29 AUGUST, 2010

 **add energy**

add wellflow as

Dynamic Simulations Deepwater Horizon Incident

DATE: August 29, 2010	REVISION / REFERENCE ID: Final	PAGES: 59
CLIENT: BP		
CONTACT: Kent Corser		
DISTRIBUTION: BP, add wellflow		

ROLE:	NAME:	SIGNATURE:
Author	Morten Haug Emilsen	<i>Morten Haug Emilsen</i>
Reviewers	Kent Corser, David Wall	

ABSTRACT:

This report summarizes the modeling and dynamic simulations performed in response to the blowout occurring at the Macondo well, MC252 #1 on the 20th of April 2010. The work was done for BP's internal Investigation Team.

Simulations were performed using OLGA-WELL-KILL¹, a software developed for well control applications. Fluid characterization and properties are generated by using PVTsim², a software developed by Calsep.

For more information about **add wellflow**, visit www.addenergy.no

KEY WORDS:

Dynamic Simulations, Well Control

REPRODUCTION:

This report is created by **add wellflow as**, Norway. The report may not be altered or edited in any way or otherwise copied for public or private use without written permission from the author.



add wellflow as
Billingstadsletta 19B
P.O. Box 165
1376 Billingstad
Norway

tel +47 66 98 32 90
fax +47 66 98 32 99

org. no. 962 238 742

addenergy.no

¹ Powered by OLGA from SPT-Group

² From Calsep

Table of Contents

SUMMARY	VI
1. BACKGROUND INFORMATION AND INPUT DATA	10
1.1 General	10
1.2 Well location	10
1.3 Water Depth	10
1.4 Drilling Rig	11
1.5 Reservoir fluid	11
1.6 Mud properties	11
1.7 Reservoir data	12
1.8 Pore and fracture pressure profile	12
1.9 Temperature profile	15
1.10 Well configuration and casing design	16
2. EVENTS LEADING UP THE WELL CONTROL INCIDENT	19
3. RESULTS	23
3.1 Oil density with pressure and temperature	23
3.2 Inflow performance	25
3.3 Compressibility of the 14 ppg mud	26
3.4 Blowout potentials	28
3.5 Shut-in pressures with hydrocarbons in the wellbore	31
3.6 Early Simulations	32
3.6.1 Introduction	32
3.6.2 Case 1 - Flow through casing assuming 12.6 ppg sand and 86 ft reservoir exposure	32
3.6.3 Case 2 - Flow through outer annulus assuming 12.6 ppg sand and full reservoir exposure	34
3.6.4 Shut-in pressure considerations	36
3.6.5 Case 3 - Flow through casing assuming 13 ppg sand and 4 ft reservoir exposure	38
3.6.6 Discussion on Cases 1-3	40
3.7 Final Simulations	41
3.7.1 Introduction	41
3.7.2 Case 4 - No influx prior to 20:02 hrs, 15 ft net pay of 12.6 ppg sand and flow through outer annulus and casing shoe	41
3.7.3 Pressure drop in surface lines	45
3.7.4 Pressure drop across a leaking annular BOP	46
3.7.5 Sensitivities with respect to potential events after 21:30	48
3.7.6 Case 5 - Well shut-in at surface at 21:30	49
3.7.7 Case 6 - BOP closing at 21:30 but not sealing until 21:47	50
3.7.8 Case 7 - BOP closed at 21:41 but not sealing until 21:47	53
3.8 Assumptions and Limitations	57
A. APPENDIX A	58
B. REFERENCES	59

List of Tables

Table 1.1:	Rheology data for synthetic oil based mud and the combined Form-A-Set and Form-A-Squeeze)spacer.....	12
Table 1.2:	Outer casing strings.....	16
Table 1.3:	Inner casing strings (cemented).....	16
Table 1.4:	Drill pipe dimensions.....	16
Table 3.1:	Float conversion attempts.....	26
Table 3.2:	Casing pressure test.....	27
Table 3.3:	Blowout potential versus flow path, net pay and exit point.....	28
Table 3.4:	Distribution of flow for casing scenario to surface.....	29
Table 3.5:	Distribution of flow for casing scenario to seabed.....	29

List of Figures

Figure 1.1:	Field location.....	10
Figure 1.2:	The Transocean Deepwater Horizon Rig.....	11
Figure 1.3:	Pore and fracture pressure profile.....	13
Figure 1.4:	Pore and fracture pressure expressed in equivalent mud weight, EMW.....	14
Figure 1.5:	Temperature profile.....	15
Figure 1.6:	Well schematic, TVD drawn to scale.....	17
Figure 1.7:	Well schematic showing volume capacities.....	18
Figure 2.1:	Recorded drill pipe pressures from 16:00 hrs to 21:49 hrs.....	20
Figure 2.2:	Recorded drill pipe pressures from 16:50 hrs to 17:20 hrs.....	21
Figure 2.3:	Recorded drill pipe pressures from 17:20 hrs to 18:40 hrs.....	21
Figure 2.4:	Recorded drill pipe pressures from 20:00 hrs to 21:49 hrs.....	22
Figure 3.1:	Oil density versus pressure for temperature = 239 °F.....	23
Figure 3.2:	Oil density versus temperature for pressure = 11,600 psia.....	24
Figure 3.3:	Volume expansion for a 40 bbl oil kick migrating to surface through 14 ppg mud.....	24
Figure 3.4:	Inflow performance curves at standard conditions based on 4 ft and 86 ft of 300 mD sand.....	25
Figure 3.5:	Inflow performance curves at reservoir conditions based on 4 ft and 86 ft of 300 mD sand.....	26
Figure 3.6:	Casing pressure test from 234 psi to 2617 psi (6.0 bbl).....	27
Figure 3.7:	Blowout potential with flow from shoe through the drill pipe and riser.....	29
Figure 3.8:	Blowout potential with flow from the shoe through drill pipe only.....	30
Figure 3.9:	Blowout potential through the casing shoe versus FWHP.....	30
Figure 3.10:	Examples of dynamic shut-in pressures, shut-in at seabed.....	31
Figure 3.11:	Case 1 - Flow through the casing assuming 12.6 ppg sand and 86 ft reservoir exposure. Simulated versus recorded drill pipe pressure.....	33
Figure 3.12:	Case 1 - Flow through the casing assuming 12.6 ppg sand and 86 ft reservoir exposure. Simulated flow rates at surface.....	33
Figure 3.13:	Case 2 - Flow through the outer annulus assuming 12.6 ppg sand and 86 ft reservoir exposure. Simulated versus recorded drill pipe pressure.....	35
Figure 3.14:	Case 2 - Flow through the outer annulus assuming 12.6 ppg sand and 86 ft reservoir exposure. Simulated flow rates at surface.....	35
Figure 3.15:	Kick and shut-in pressures.....	37
Figure 3.16:	Shut-in pressures with no hydrocarbons and seawater in drill pipe.....	38
Figure 3.17:	Case 3 - Flow through the casing assuming 13.0 ppg sand and 4 ft reservoir exposure. Simulated versus recorded drill pipe pressure.....	39
Figure 3.18:	Case 3 - Flow through the casing assuming 13.0 ppg sand and 4 ft reservoir exposure. Simulated flow rates at surface.....	40
Figure 3.19:	Pressure profile in outer annulus to balance 13 ppg sand.....	42
Figure 3.20:	Pump schedule during the period between 20:00 hrs – 21:30 hrs. Recorded data versus input to model.....	43
Figure 3.21:	Case 4 - Flow through casing assuming 12.6 ppg sand and 15 ft reservoir exposure. Simulated versus recorded drill pipe pressure.....	44
Figure 3.22:	Case 4 - Flow through casing assuming 12.6 ppg sand and 15 ft reservoir exposure. Simulated flow rates at surface.....	44
Figure 3.23:	Frictional pressure loss in 500 ft pipe with 14 ppg mud.....	45

Figure 3.24: Annular blowout preventer 46
Figure 3.25: Pressure drop across BOP for various rates of BOP closure 47
Figure 3.26: Pressure fluctuations the last minutes before explosion 48
Figure 3.27: Case 5 - Pressure response for a sudden shut-in at surface (no flow) 49
Figure 3.28: Case 6 - Simulations of circulation with flow through shoe, pressure buildups (pressure match by means of a controller) 51
Figure 3.29: Case 6 - Simulated pressure response for an instantaneous opening of blowout preventer annular 52
Figure 3.30: Case 6 - Simulated pressure response for a bleed back through drill pipe at surface.... 52
Figure 3.31: Case 7 - Pressure response for simulations without closing BOP (not accounting for the surface bleed) 54
Figure 3.32: Case 7 - Pressure response for simulations with closing annular from 21:41 hrs (not accounting for the surface bleed). 55
Figure 3.33: Case 7 - Inflow and hydrocarbon volume with closing annular from 21:41 hrs (not accounting for the surface bleed). 55
Figure 3.34: Case 7 - Flow and pressure at surface with closing annular from 21:41 hrs (not accounting for the surface bleed). 56
Figure 3.35: Case 7 - Pressure below and above the BOP when closing annular from 21:41 hrs (not accounting for the surface bleed). 56

Summary

This report summarizes the dynamic simulations and evaluations performed in response to the Deepwater Horizon blowout that occurred on the 20th of April 2010. The incident occurred following a negative test performed to check the integrity of the well barriers (cement, float, casing and seal assembly). The rig personnel concluded the test was successful and the incident happened as they displaced the riser to seawater.

The analysis presented in this report was performed to gain a better understanding of the following questions:

- What was the likely flow path of the hydrocarbons to surface?
- What caused the drill pipe pressure transients during the last 30 minutes of the recorded data?
- When was the BOP operated and how did it perform?
- What was the volume of the hydrocarbons released to surface prior to the explosion?

The evaluations and findings made during this work (to the date of this report) are based on witness accounts, mud-logging data, cement-unit data, well design, reservoir properties and reservoir fluid composition.

A detailed dynamic OLGA-WELL-KILL network model was built, used and found to be a valuable tool for analyzing and understanding the transients occurring in the wellbore right before the explosion. The model includes the casing, the drill pipe, the boost line, the outer annulus, the riser, the surface piping, the mud-gas separator, pumps, valves and control systems. The fluids include seawater, 16 ppg high viscosity spacer (a combination of Form-A-Set and Form-A-Squeeze), 14 ppg mud and hydrocarbons. The start time of the simulation model is 15:00 hrs when the entire wellbore was filled with 14 ppg mud. The simulations were performed following the operations for the entire period between 15:00 hrs and 21:49 hrs.

As more information became available to the Investigation Team, the model had to be updated leading to a series of simulations. Some of these initial simulations are discussed in the report to provide the reader additional context on the scenarios considered.

The main reservoir in the MC252 Macondo prospect well consists of two oil bearing sands, the Upper and the Lower M56. Both sands have a pore pressure of 12.6 ppg. The top of the Upper M56 is at 18,086 ft TVD RKB and only a few feet separates the upper and the lower sands. The reservoir sands are very prolific. Based on 300 mD and 86 ft net pay, the inflow performance curve indicates a productivity index of 49 stb/d/psi for pressures above the bubble point pressure. This contributes to a fast unloading of the well if it is left open to flow in an underbalanced condition. For example a drawdown of only 1,000 psi results in an influx of 73 bpm of oil from the reservoir into the wellbore. This is equivalent to a rate of 34 stb/m at surface conditions, the oil formation volume factor is 2.14 bbl/stb.

It is probable that the sands were restricted to some degree by the cement and downhole equipment and that the resulting reservoir exposure is less than the total reservoir thickness.

As insights were gained from the initial simulations that were completed and more information became available from the investigation team, it was possible to converge on the inputs for further simulations to be completed. The main simulation runs that were completed are described in Section 3.6 (Early Simulations) and Section 3.7 (Final Simulations). In Section 3.6, the early simulations, a large net pay assumption of 86 ft was used and cases for flow through the production casing and through the production casing outer annulus were evaluated. In Section 3.7, the final simulations, net pay assumptions between 13 ft and 16.5 ft were used and most of the cases run were based on flow through the production casing via the casing shoe. In the simulations described in section 3.7, it was possible to achieve a good match with the recorded data using this relatively small range of net pay input assumptions. Achieving a simulation match to some of the recorded data, such as the arrival time of gas at surface and the pressure fluctuations recorded on the drill pipe after 21:30 hrs, proved to be quite sensitive to this narrow band of net pay input assumptions.

Constant net pay input assumptions were used for all of the simulations and it is acknowledged that varying net pay is probably more likely; this may explain some of the offsets between actual recorded data and the simulation results. However, the model results can be confidently utilized by the investigation team to test different well flow hypotheses when used in conjunction with other sources of information such as recorded real time data and witness accounts.

Conclusions:

The available evidence and simulation results strongly suggest that the initial flow path was through a leaking casing shoe and up through the inside of the casing. Using the input data collected by the investigation team, it was not possible to simulate flow through the outer annulus of the casing and match the recorded data and actual events witnessed. It was also clear that key points of reference such as a pressure increase during the sheen test could not be generated by flow through the outer annulus of the casing, the simulation shows a pressure decrease during this period of time rather than a pressure increase.

By using a net pay of between 13 ft and 16.5 ft and assuming flow via the casing shoe and through the production casing, a good simulation match for most of the actual events witnessed and data recorded can be achieved. Using a net pay of between 13 ft and 16.5 ft also seems realistic; it is less than 1/5th of the total productive sands in the well. The final simulation run which is based on these parameters, Case 7, is described in Section 3.7.8 of the report.

According to the simulations, the well became underbalanced at 20:52 hrs resulting in flow of hydrocarbons into the wellbore. Simulations show a total gain of around 40 bbls taken between 20:52 hrs and 21:08 hrs, a result supported by the gains calculated from recorded mud-pit data.

At 21:08 hrs, a sheen test was performed to verify that all the mud was displaced and the spacer had reached the surface. Between 21:08 hrs and 21:14 hrs, when the mud pumps were shutdown, the pressure on the drill pipe increased by more than 200 psi. This pressure increase could not be modeled by assuming flow through the outer annulus of the production casing, this model case showed a decrease in pressure rather than an increase. This 200 psi pressure increase could be modeled by assuming flow through the production casing shoe.

At approximately 21:10 hrs, during the sheen test, the flow was then routed to an overboard line bypassing the flow meters. From this point forward the flow from the well would have continued, but it appears that it went undetected by the rig crew.

At 21:14 hrs the mud pumps were restarted to displace the riser fully to seawater, this pumping operation continued until 21:30 hrs. The well would have continued to flow due to a significant amount of hydrocarbons already being in the wellbore causing a high under-balance with the reservoir pressure.

At 21:31 hrs, after the pumps had been shut down, there was a pressure increase in the well. This can be explained either by a mechanical closure downhole or the hydrostatic effect of mud flowing up the casing/drill pipe annulus. There is no indication that the rig crew had taken actions to close the BOP at that stage, therefore, it is thought that this first pressure increase was probably created by hydrostatic effects in the well rather than mechanical restrictions.

There was a pressure transient event between 21:36 hrs and 21:38 hrs with a very rapid pressure drop and then increase of over 1,000 psi. Simulations suggest that this was probably caused by bleeding through the drill pipe at surface. When trying to simulate this effect mechanically at the BOP by instantaneous opening and closing of a BOP element, the pressure transient effect created a much slower pressure response than was actually recorded during the event. The recorded sharp pressure response could be simulated by bleeding off the drill pipe pressure at surface.

The pressure increase during the last 8 minutes was likely due to the actions taken by the crew to close the BOP starting at approximately 21:41 hrs. Simulations indicate a more rapid increase in drill pipe pressure would have resulted if the well was shut-in and sealed at this time. However, the recorded data shows that this rapid pressure increase did not happen until 21:47 hrs. It is possible that the crew closed one of the annular preventers at 21:41 hrs but it failed to seal. Other evidence which supports this theory is as follows:

- Witness accounts indicate that well control action was not taken until about 21:41 hrs
- There were erosion marks on the retrieved drill pipe suggesting high velocity flow through an annular
- The simulations show that to create the recorded pressure response a BOP element would need to be almost fully closed (about a 99% closure).

At 21:47 hrs the rapid pressure increase in the drill pipe could be simulated by a BOP element fully sealing the well.

The last actual pressure recording on the drill pipe was 5,730 psi. According to the simulations, this pressure corresponds to a shut-in pressure with hydrocarbons in the wellbore up to the BOP and the drill pipe full of seawater.

If, as assumed, a BOP element was closed at seabed, the hydrocarbon flow to surface should have ceased at about 22:00 hrs. The investigation team have identified several potential causes explaining why the flow to surface continued and fueled the fire. These causes include, rig drift-off pulling the drill pipe through the BOP and breaking the BOP element seal and/or surface equipment failure creating a flow path through the drill pipe.

The volume of the drill pipe is 207 bbls, initially filled with water and some mud or hydrocarbons from the short bleed down. This volume would be unloaded in 2 minutes according to the simulations. After closing the BOP, the riser will still flow and unload due to the presence of hydrocarbons above the BOP. If the subsequent fire is fueled through the drill pipe, the flow rate through the drill pipe to surface based on an assumed net pay of 15 ft, is estimated to be 28,000 stb/d. If the subsequent fire is fueled through the riser, the flow rate through the riser to surface based on an assumed net pay of 15 ft, is estimated to be 41,000 stb/d.

It should be noted that these flow rates should not be considered as representative of the flow rates that occurred after the fire and explosion. There would have been different mechanical restrictions involved and probably different and varying levels of net pay open to flow. No work was completed in this report to consider flow rates from the well following the initial fire and explosion.

1. Background Information and Input Data

1.1 General

On April 20th 2010, a fire and explosion occurred onboard the Deepwater Horizon rig while it was working on the Macondo well prospect offshore Louisiana. The rig had cemented the casing and complications occurred during and after performing a negative test (standard procedure to test the cement job). Explosions occurred with subsequent fire and uncontrolled flow of hydrocarbons and a total loss of well control. The rig sank April 22nd.

An investigation team was established to evaluate the causes of the accident. Add wellflow was asked to contribute to the investigation by completing dynamic analysis, simulations and evaluations, and this report summarizes the work performed.

1.2 Well location

The well is located on the Macondo prospect situated on Mississippi Canyon block 252 (MC 252), offshore Louisiana, Gulf of Mexico, 52 miles southeast of the Louisiana port of Venice.

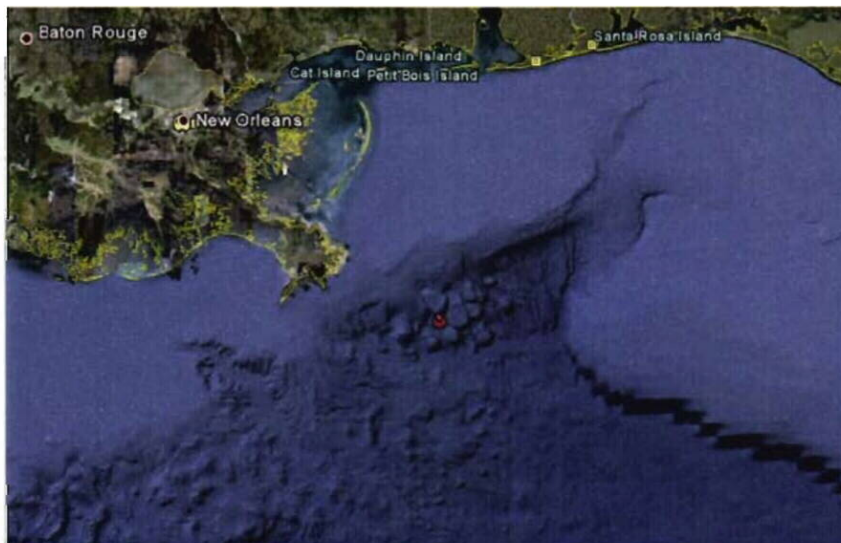

Figure 1.1: Field location

1.3 Water Depth

The water depth at the spud location is 4,992 ft MSL.

1.4 Drilling Rig

The Deepwater Horizon was a dynamic positioned semi-submersible drilling unit capable of operating in harsh environments and water depths over 9,000 ft using 18 ¾" 15,000 psi BOP and 21" OD (19 ½" ID) marine riser. The air gap (RKB – MSL) is 75 ft.



Figure 1.2: The Transocean Deepwater Horizon Rig

1.5 Reservoir fluid

An analysis of the specified reservoir fluid composition reveals an under-saturated oil with a bubble point at 6,500 psi at reservoir temperature and a GOR of 2,824 scf/stb. The reservoir fluid composition has been used to generate all the thermodynamical properties required for the analyses, but is not included in this report.

1.6 Mud properties

The dynamic simulations reproduce the trends shown by the data logs. For operations involving flow of the spacer (a combination of Form-A-Set and Form-A-Squeeze), the pressure drop in the system was higher than what was estimated by the model. A non-Newtonian Bingham viscosity model was used but could still not reproduce the viscous behavior of the spacer. This effect was compensated by introducing additional pressure drop at the outlet of the wellbore. Rheology tests performed after the incident using a viscometer showed off scale readings and indicated very high viscosity for the combined Form-A-Set and Form-A-Squeeze spacer. This highly viscous non-Newtonian fluid is believed to be causing the discrepancy in simulated pressures versus actual recorded data during the period that the spacer is still in the riser. Table 1.1 shows the numbers used for the spacer and for the 14 ppg synthetic oil based mud.

Table 1.1: Rheology data for synthetic oil based mud and the combined Form-A-Set and Form-A-Squeeze)spacer

	SOBM	Spacer
Density, ppg	14	16
Plastic viscosity, cP	28	324
Yield Point, lbf/100 ft ²	14	34
10 sec gel, lbf/100 ft ²	14	31
10 min gel, lbf/100 ft ²	23	38

1.7 Reservoir data

The main reservoir in the Macondo well consists of two oil bearing sands, the Upper M56 and the Lower M56. Both sands have a pore pressure of 12.6 ppg. The top of the Upper M56 is at 18,086 ft TVD RKB and only a few feet separate the upper and the lower sands. The reservoir sands are very prolific. Based on 300 mD and 86 ft net pay, the inflow performance curve indicates a productivity index of 49 stb/d/psi for pressures above the bubble point pressure. This contributes to a fast unloading of the well when it is left open to flow in an underbalanced condition. For example, a drawdown of only 1,000 psi results in an influx of 73 bpm of oil from the reservoir into the wellbore. This is equivalent to a rate of 34 stb/m at surface conditions, the oil formation volume factor is 2.14 bbl/stb. It is probable that the sands will be restricted by the cement and that the resulting reservoir exposure is less than the total reservoir thickness. A net pay of between 13 ft to 16.5 ft was used in the final simulations represented in Case 7 (see Section 3.7.8) and this gave a good match with the recorded data.

1.8 Pore and fracture pressure profile

The pore and fracture pressure profiles are shown in Figure 1.3 and Figure 1.4.

Pore and fracture pressure

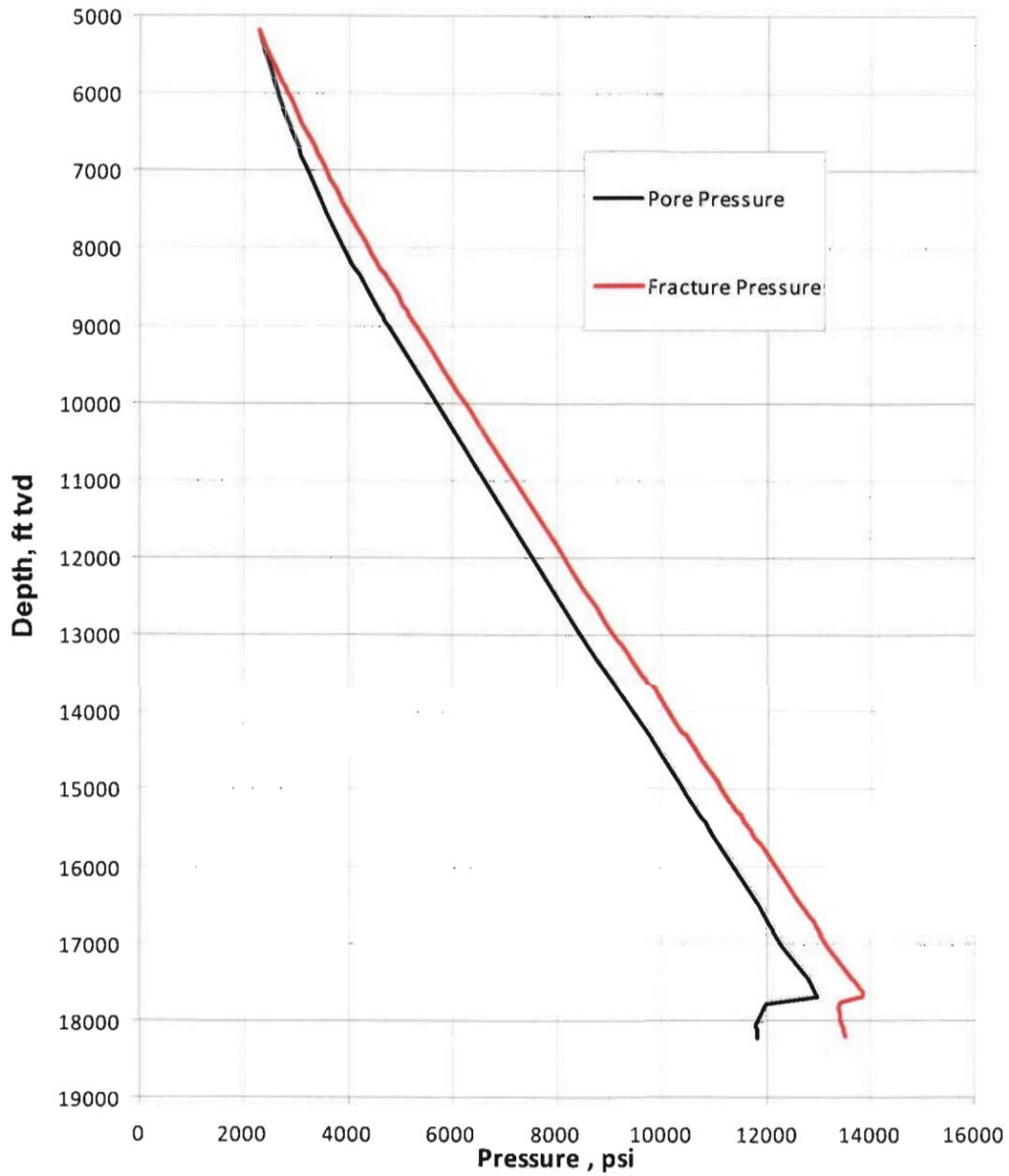

Figure 1.3: Pore and fracture pressure profile

Pore and fracture pressure, EMW

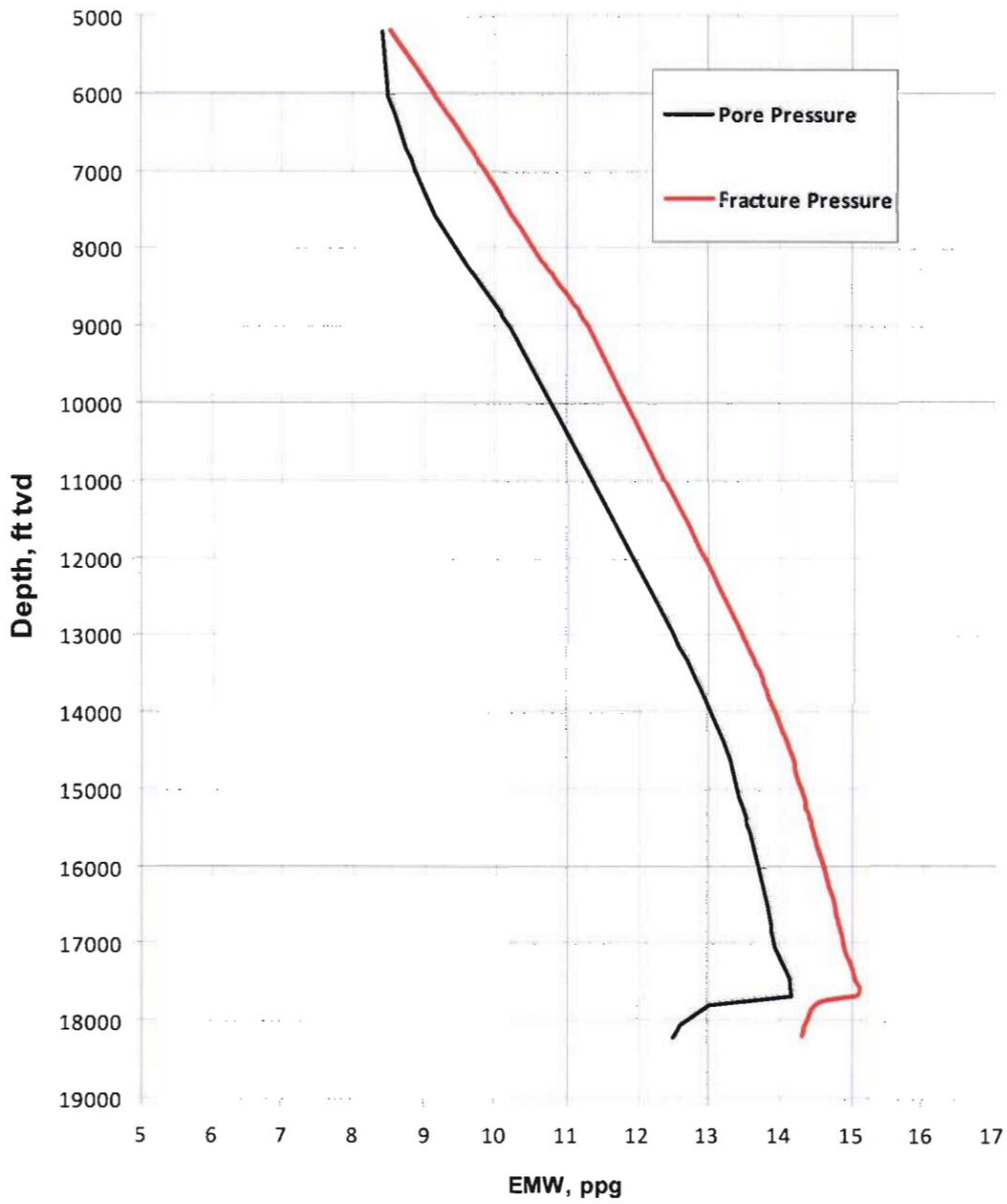

Figure 1.4: Pore and fracture pressure expressed in equivalent mud weight, EMW

1.9 Temperature profile

The temperature profile is shown in Figure 1.5.

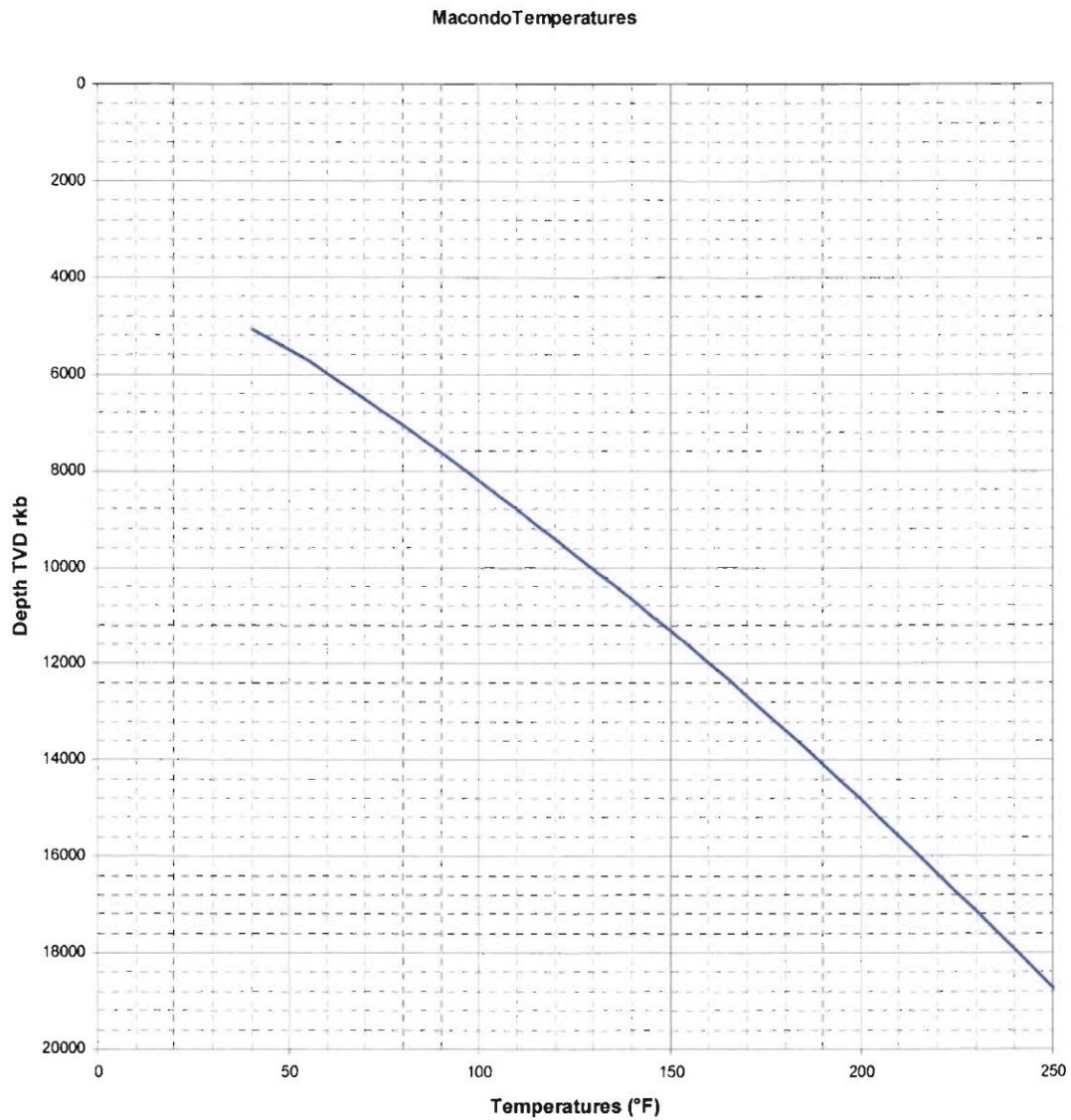

Figure 1.5: Temperature profile

1.10 Well configuration and casing design

The pipe dimensions for the outer casing strings are listed in Table 1.2; dimensions for the inner casing strings are listed in Table 1.3; the dimensions for the drill pipe are listed in Table 1.4. The total volume inside the casing up to seabed is 746 bbl. The volume in the outer annulus is 1,180 bbl. The volume in the annulus between the riser and the drill pipe is 1,640 bbl. The volume inside the drill pipe is 207 bbl. Figure 1.6 shows a schematic of the well with depths at scale while Figure 1.7 shows the wellbore capacities.

Table 1.2: Outer casing strings

	Weight lb/ft	OD in	ID in	Top ft	Bottom ft	Length ft	Capacity bbl/ft
Choke/Kill			4.5	0	5067	5067	0.019672
Riser		21	19.5	0	5001	5001	0.369390
BOP			18.75	5001	5054	53	0.341522
Wellhead			18.5	5054	5057	3	0.332475
22" Casing		22	18.375	5057	5227	170	0.327998
16" Casing	97	16	14.85	5227	11153	5926	0.214224
13 3/8" Liner	88.2	13.375	12.375	11153	12803	1650	0.148767
11 7/8" Liner	71.8	11.875	10.711	12803	14759	1956	0.111449
9 7/8" Liner	62.8	9.875	8.625	14759	17157	2398	0.072266
Open Hole			9.875	17157	18130	973	0.094731
Rat Hole			8.5	18130	18360	230	0.070187

Table 1.3: Inner casing strings (cemented)

	Weight lb/ft	OD In	ID In	Top ft	Bottom ft	Length ft	Capacity bbl/ft
9 7/8" x 7" Tapered Csg	62.8	9.875	8.625	5067	12484	7417	0.072266
9 7/8" x 7" Tapered Csg	32	7	6.094	12484	18303	5819	0.036076

Table 1.4: Drill pipe dimensions

	Weight lb/ft	OD in	ID in	Top ft	Bottom ft	Length ft	Capacity bbl/ft
6 5/8" DP	32	6.625	5.426	0	4177	4177	0.028601
5 1/2" DP	21.9	5.5	4.78	4177	7567	3390	0.022196
3 1/2" DP	9.3	3.5	2.992	7567	8367	800	0.008696

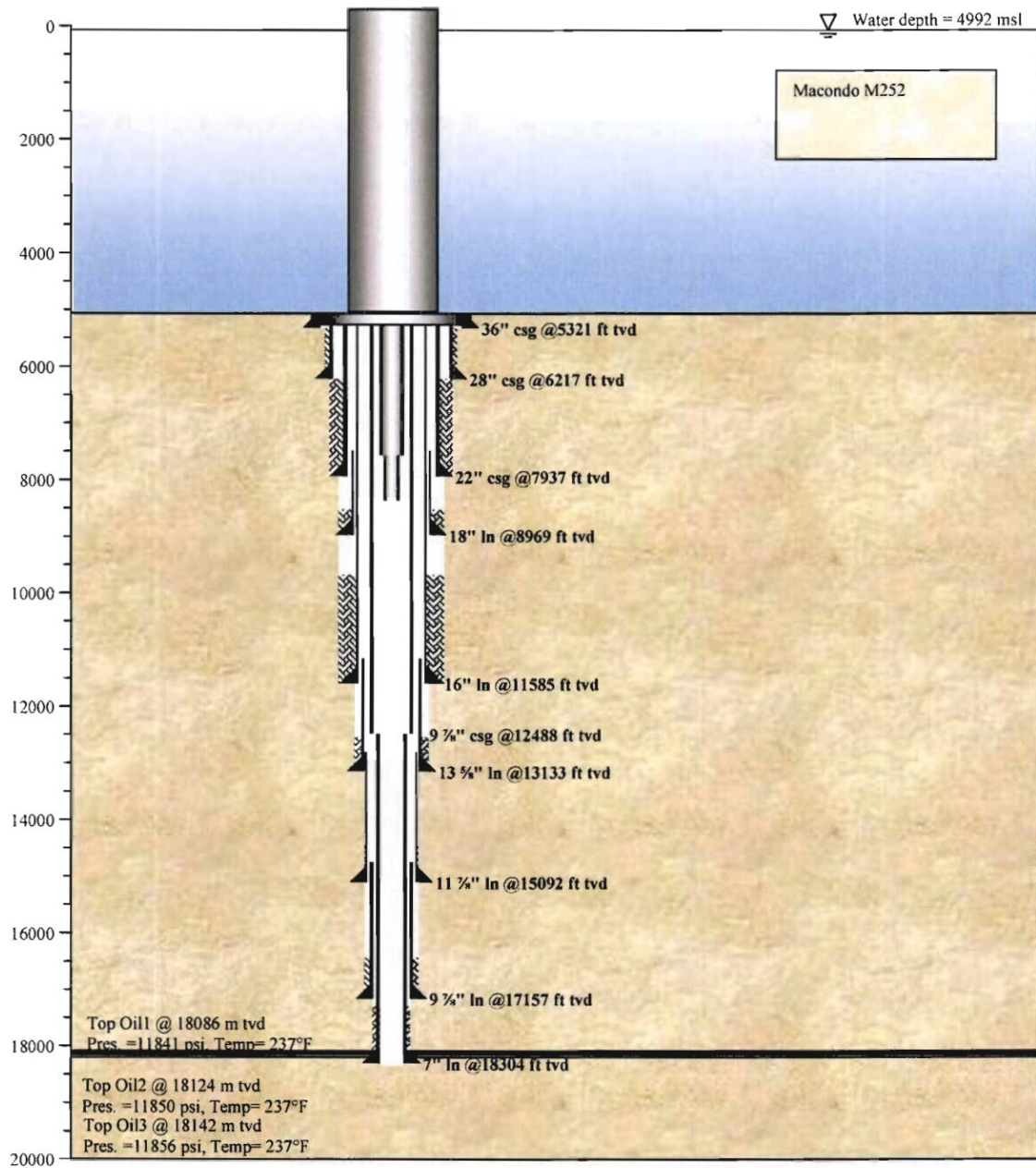

Figure 1.6: Well schematic, TVD drawn to scale

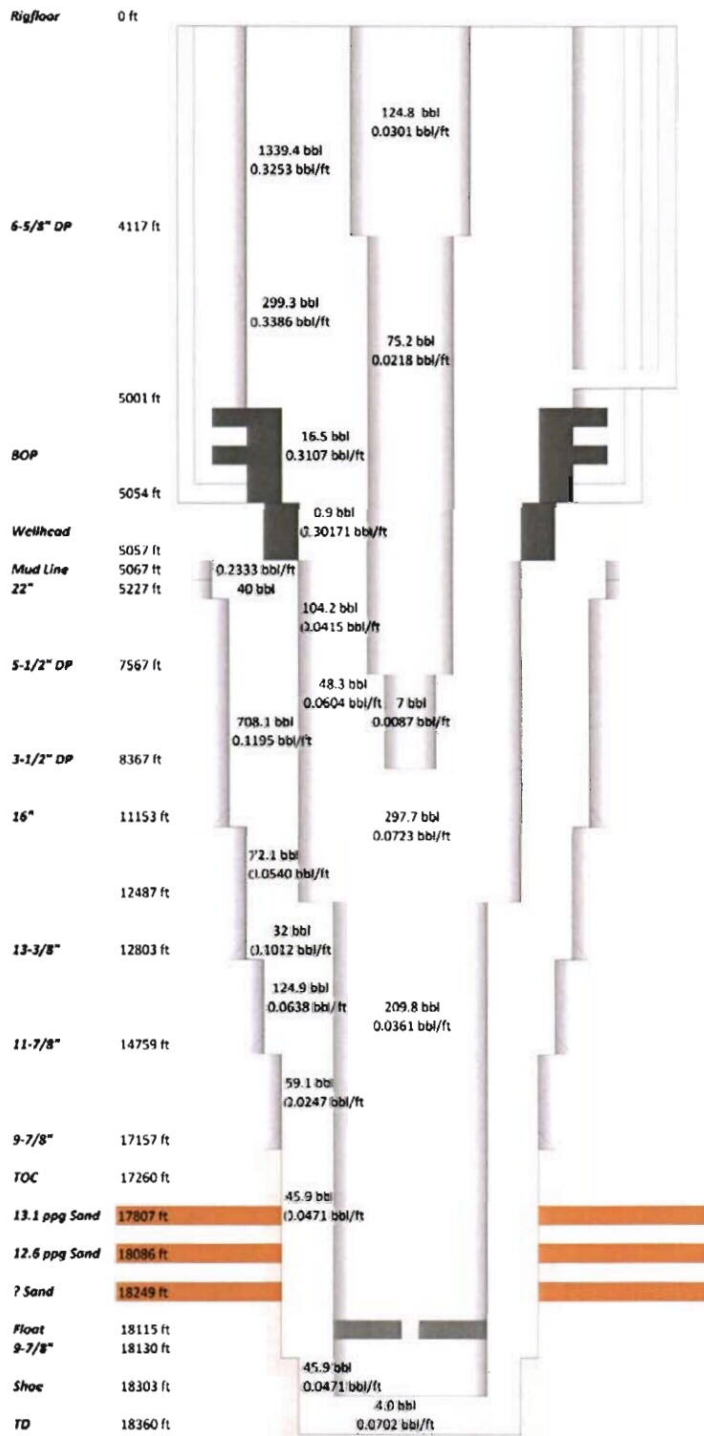

Figure 1.7: Well schematic showing volume capacities

2. Events leading up the well control incident

The well was drilled to target depth (TD) at 18,350 ft TVD and the 9 7/8 x 7" production casing was run and cemented. It took nine attempts to convert the float equipment before it appeared to have converted and the cementing could start. 14 ppg mud was in the wellbore.

After cementing, the 9 7/8" seal assembly was set and tested to 6,500 psi followed by a casing test to 2,600 psi. It took 6.7 bbls to pressurize the casing from 0 to 2,600 psi.

A tapered drill pipe (6 5/8" – 5 1/2" – 3 1/2") was run to 8,367 ft before the negative test. The boost, choke and kill lines were displaced to seawater. A batch of 424 bbl of 16 ppg spacer and 30 bbl of fresh water was pumped followed by 352 bbl of seawater. The plan was to pump the spacer just above the BOP stack; because the BOP annular leaked the spacer was drawn down across the BOP during the subsequent bleed offs. The pressure on the drill pipe was 2,400 psi after the water was pumped. The annular preventer was then closed.

The pressure was bled down from 2,400 psi to 1,200 psi through the drill pipe and larger than predicted bleed back volumes were observed. The bleed down was continued, but the pressure did not decrease below 250 psi, and the well was subsequently shut in. Witness accounts vary with respect to bleed back volumes. According to witness statements, the riser was filled up with 50 – 60 bbl during this period. After the bleed down, the pressure increased to 1,250 psi during a period of 7 minutes.

During further attempts to set-up for the negative test additional volumes were recovered from the well; there is uncertainty in the exact volume of fluid that was bled from the well compared with how much fluid was added when topping up the riser. The best estimate of the investigation team is that between 60 - 85 bbls of fluid were bled from the well and between 50 - 60 bbls of fluid were added to the well during the riser top-up. When including the effect of fluid compressibility it is possible that an influx of anything from between 0 to 20 bbls of hydrocarbon occurred during the negative test.

Following the bleed downs whilst setting up for the negative test, the pressure on the drill pipe gradually increased from 200 psi to 1,400 psi over a 30 minutes period, the pressure stabilized at 18:35 hrs (see Figure 2.1). At 20:02 hrs, the pumps were started to displace the mud and spacer with seawater. The pumps were shut down for a sheen test at 21:08 hrs and the test indicated that the fluids could be discharged overboard. The pumping resumed after the sheen test was completed at approximately 21:14 hrs and continued until 21:30 hrs when the pumps were shut down.

After 21:31 hrs there was a pressure increase followed by a rapid pressure drop and increase between 21:36 hrs and 21:38 hrs. The pressure then dropped followed by a second pressure increase at approximately 21:41 hrs and finally by a rapid increase at approximately 21:47 hrs. The data stream ends at 21:49 hrs. The simulations attempted to provide an explanation for the causes of these pressure fluctuations.

Witness accounts suggest that it is unlikely that any action was taken to shut-in the well with a BOP element before 21:41 hrs, if so, the pressure fluctuations before 21:41 hrs cannot be explained by simulating the closure of a BOP element.

Witness accounts also suggest that mud was seen flowing (cascading) off the rig floor and then up through the derrick before the rig crew diverted to the mud gas separator (MGS). Mud was then seen raining down from the derrick, most likely due to an overfilled MGS and vent line. Simulations were conducted to replicate this sequence of events to allow the investigation team to understand probable surface flow rates and surface equipment operating pressures. These simulations supported the investigation team in assessing surface equipment failure modes and in developing a gas dispersion model.

At approximately 21:49 hrs, the first explosion occurred and the lights went out almost simultaneously. Approximately 10 seconds later, per witness accounts, a second explosion occurred. These timings indicate that there were significant gas volumes at surface at this time and the simulations needed to be able to replicate this reality.

The following plots show the drill pipe pressure recorded from 16:00 hrs till the explosions occurred at 21:49 hrs.

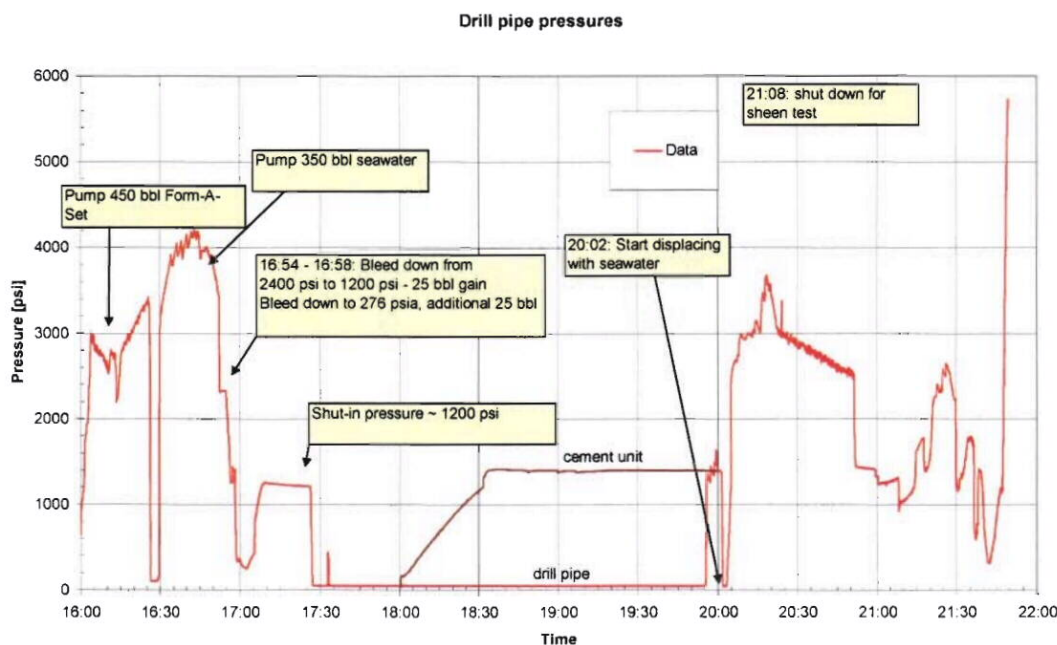

Figure 2.1: Recorded drill pipe pressures from 16:00 hrs to 21:49 hrs

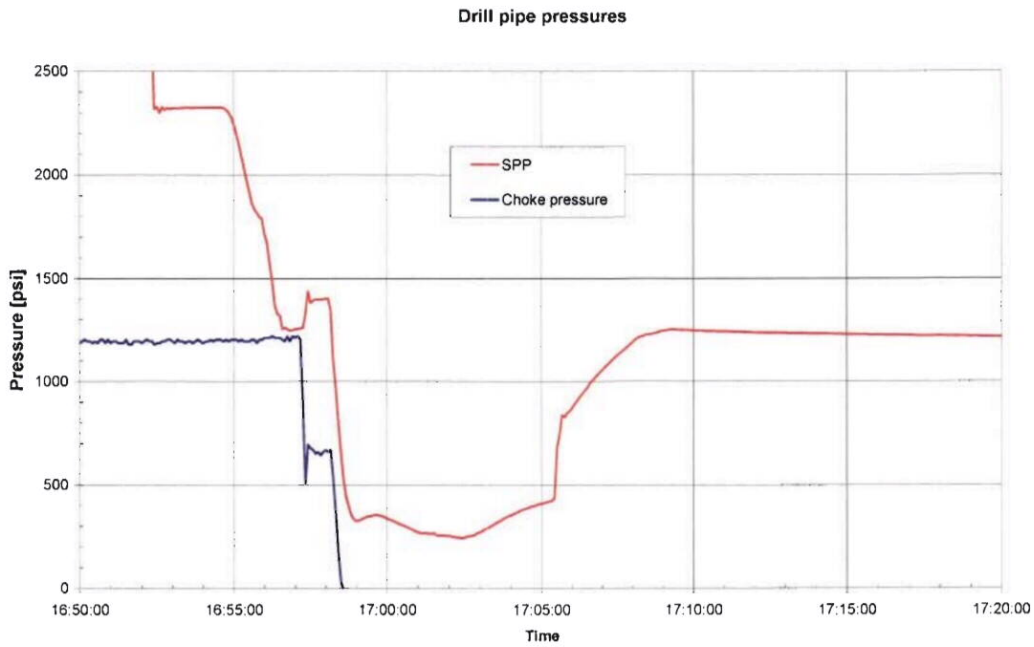

Figure 2.2: Recorded drill pipe pressures from 16:50 hrs to 17:20 hrs

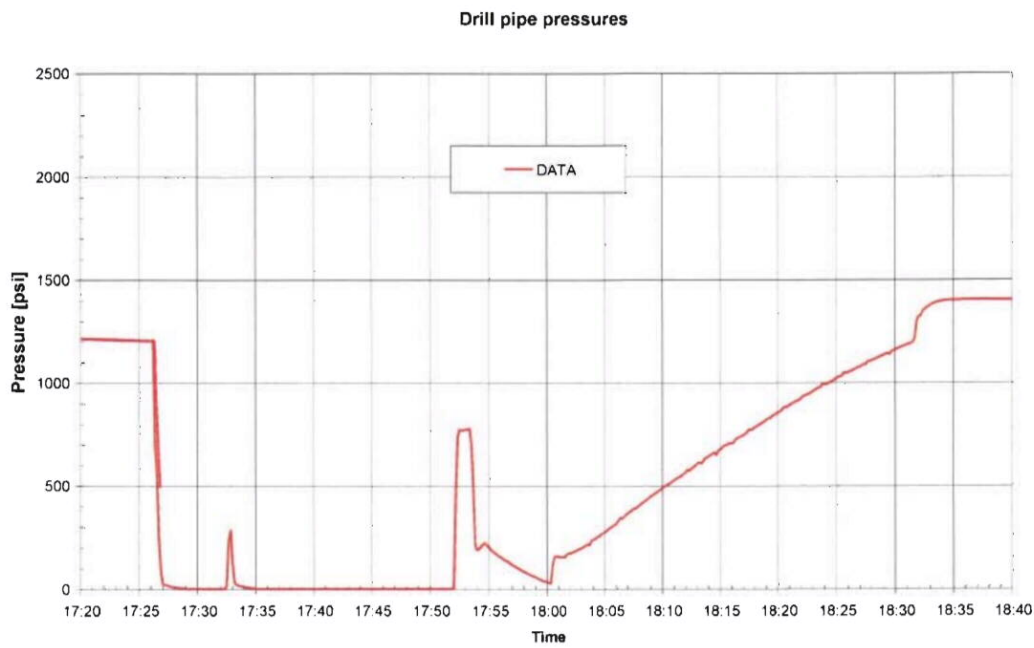

Figure 2.3: Recorded drill pipe pressures from 17:20 hrs to 18:40 hrs

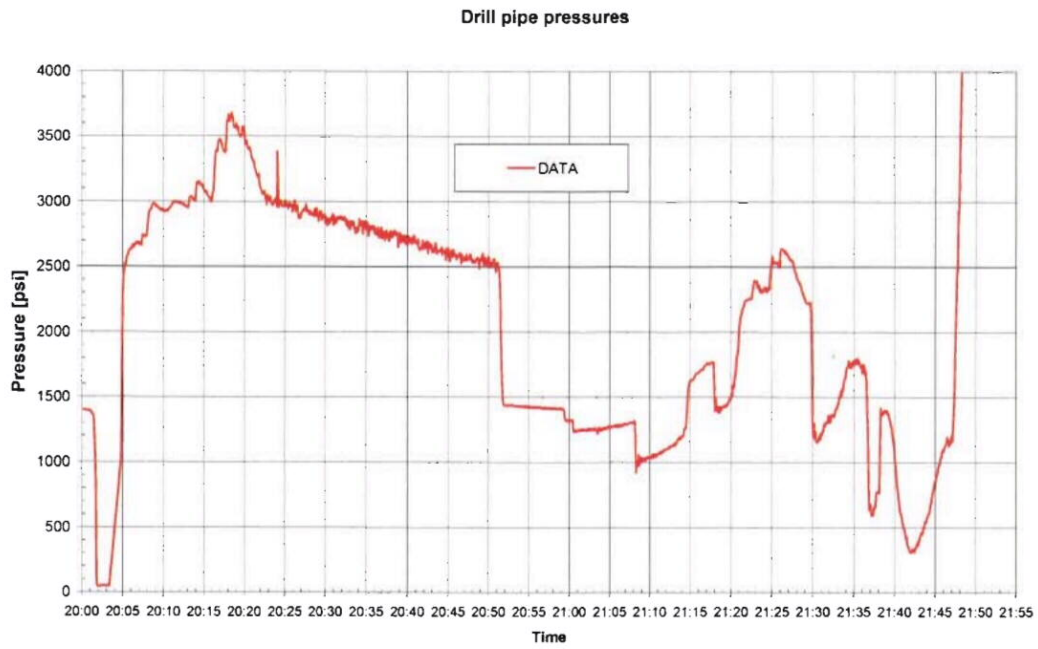

Figure 2.4: Recorded drill pipe pressures from 20:00 hrs to 21:49 hrs

3. Results

3.1 Oil density with pressure and temperature

The reservoir fluid is an under-saturated oil with a bubble point at 6,500 psi at reservoir temperature. The density of the oil phase will decrease with decreasing pressure (see Figure 3.1) and increase with decreasing temperature (see Figure 3.2). These two effects will almost balance each other when an oil kick is taken and slowly migrates towards the surface through the mud. The resulting volume expansion is almost zero (see Figure 3.3).

This type of density behavior would challenge the detection of any small oil kick (small influx of hydrocarbons). After an oil kick (assuming there was no continued influx) there would be no significant volume gain until the hydrocarbon is just below the BOP. Just below the BOP, with 14 ppg mud in the wellbore, gas would start to break-out and create further gains at surface. The crew would have less time to react to an isolated kick, and once a well control problem is confirmed, a late detection can mean that gas is already inside the riser before the crew recognizes there is a well control issue and closes the BOP. This behavior is different from a gas kick, but still not uncommon for deepwater drilling operations. Awareness and knowledge of these mechanisms is important.

However, it is noted that the Macondo accident was not caused by a small oil kick but by a continuous influx of hydrocarbons in the wellbore resulting in significant gained volumes that should have been detectable.

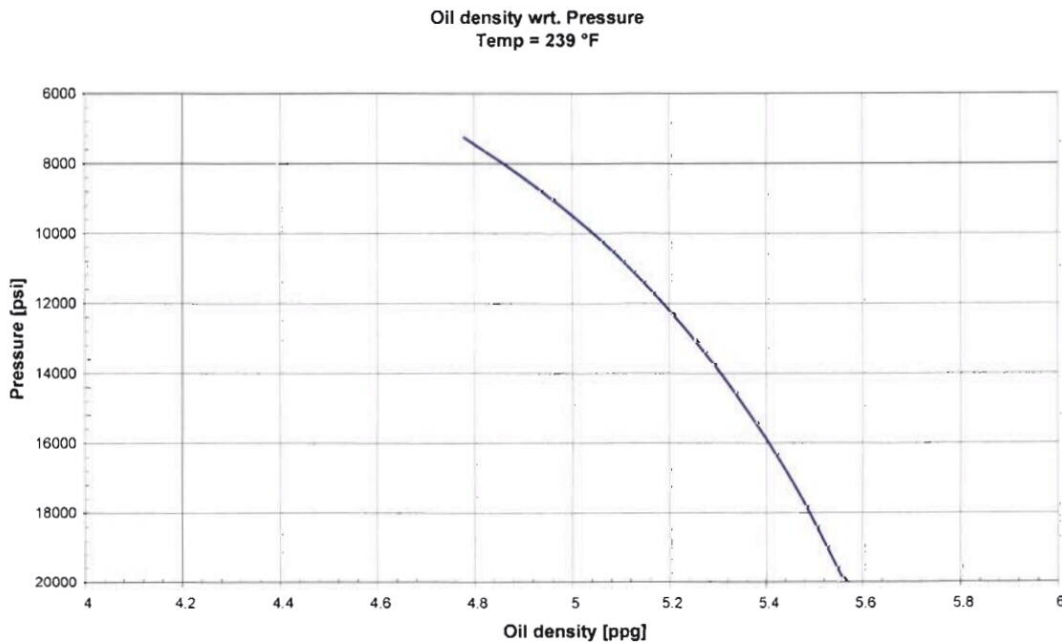

Figure 3.1: Oil density versus pressure for temperature = 239 °F

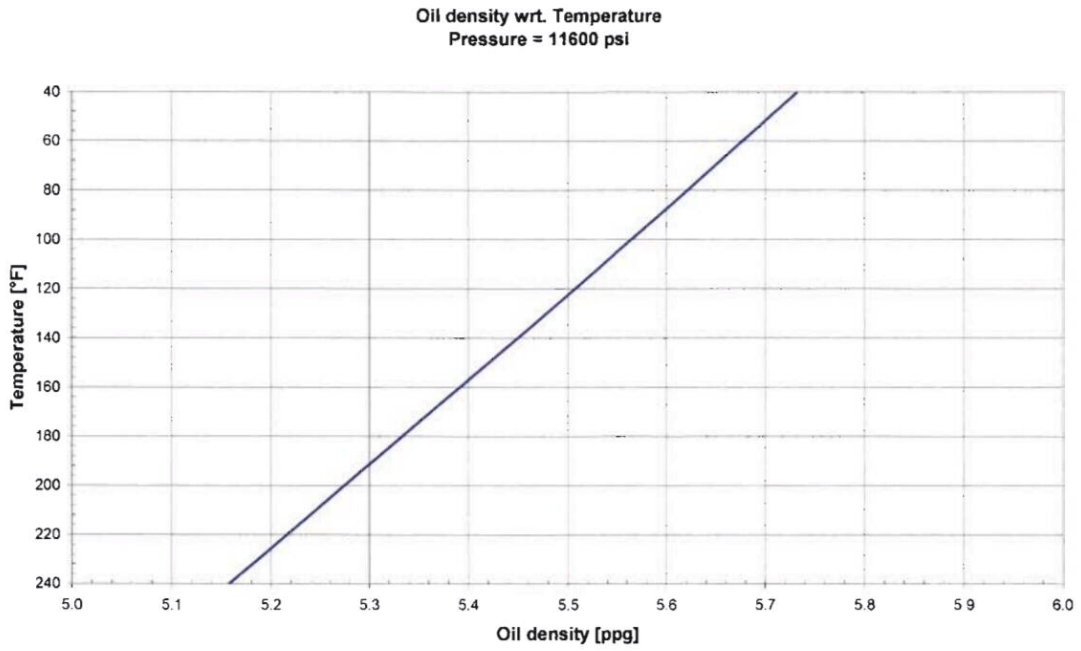

Figure 3.2: Oil density versus temperature for pressure = 11,600 psia

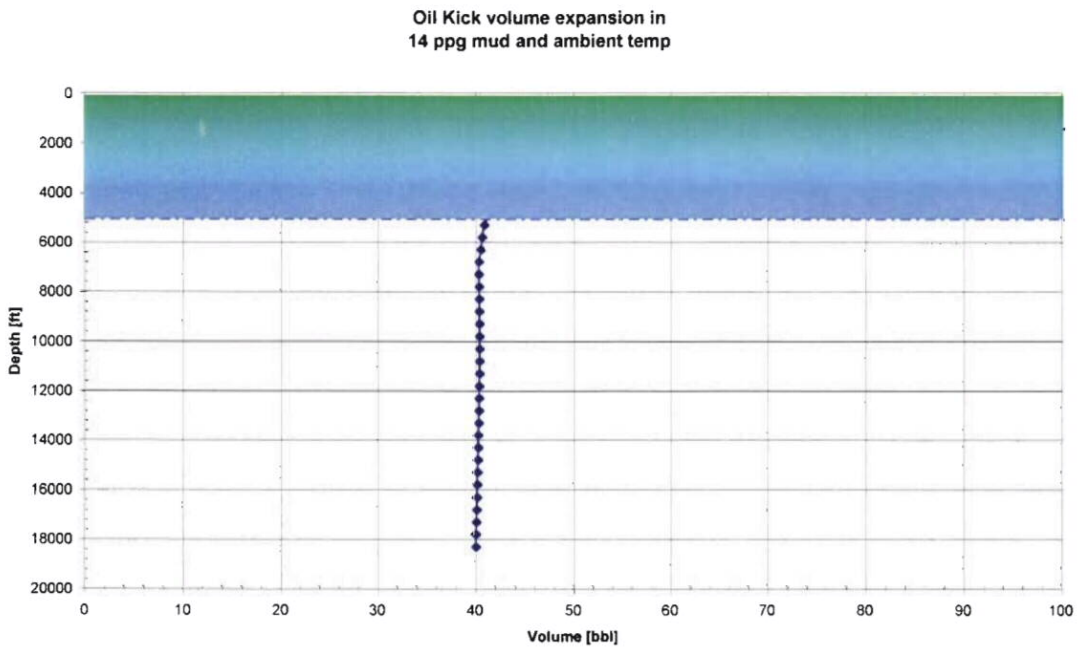

Figure 3.3: Volume expansion for a 40 bbl oil kick migrating to surface through 14 ppg mud

3.2 Inflow performance

The 12.6 ppg pressured oil sands have an estimated average permeability of 300 mD over 86 ft of net pay. This, together with the fluid properties, will result in a productivity index of 49 stb/d/psi from reservoir pressure down to the bubble point pressure at 6,500 psi. For pressures below the bubble point, gas will flash out of solution, and turbulent skin effects will limit the flow potential. Figure 3.4 shows the resulting inflow performance based on 4 ft reservoir exposure and 86 ft reservoir exposure. As can be seen, the reservoir is very prolific.

Due to the high oil formation volume factor (shrinkage factor) of 2.14 Rbbl/Stb, the volumetric inflow rate at reservoir conditions is more than twice as high as those reported at standard conditions. Figure 3.5 shows the inflow performance at reservoir conditions (in-situ conditions).

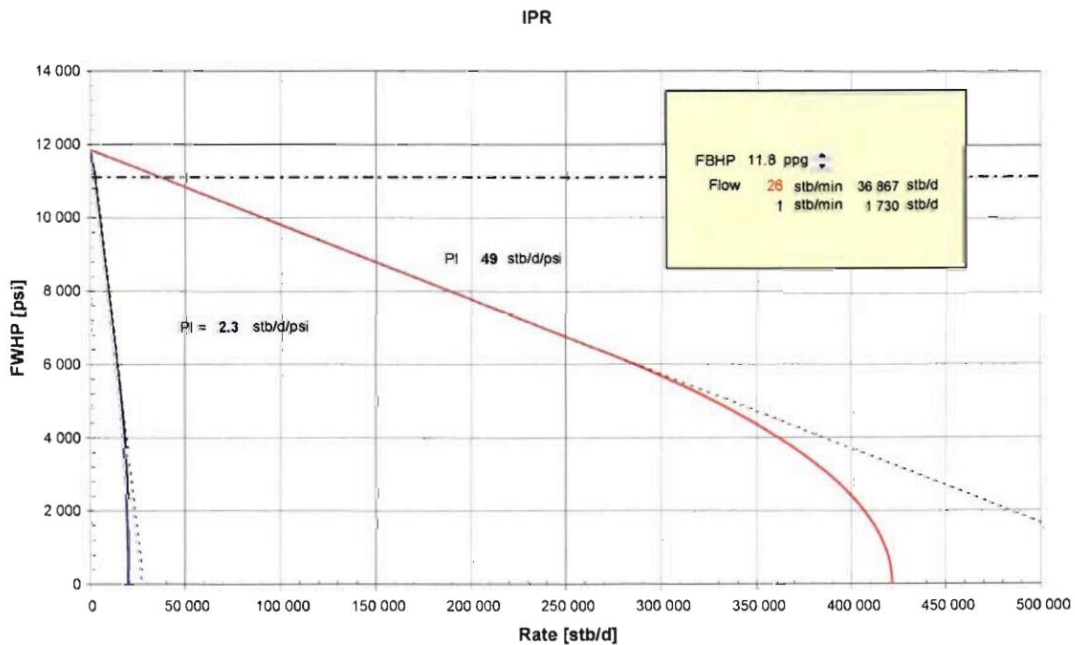

Figure 3.4: Inflow performance curves at standard conditions based on 4 ft and 86 ft of 300 mD sand

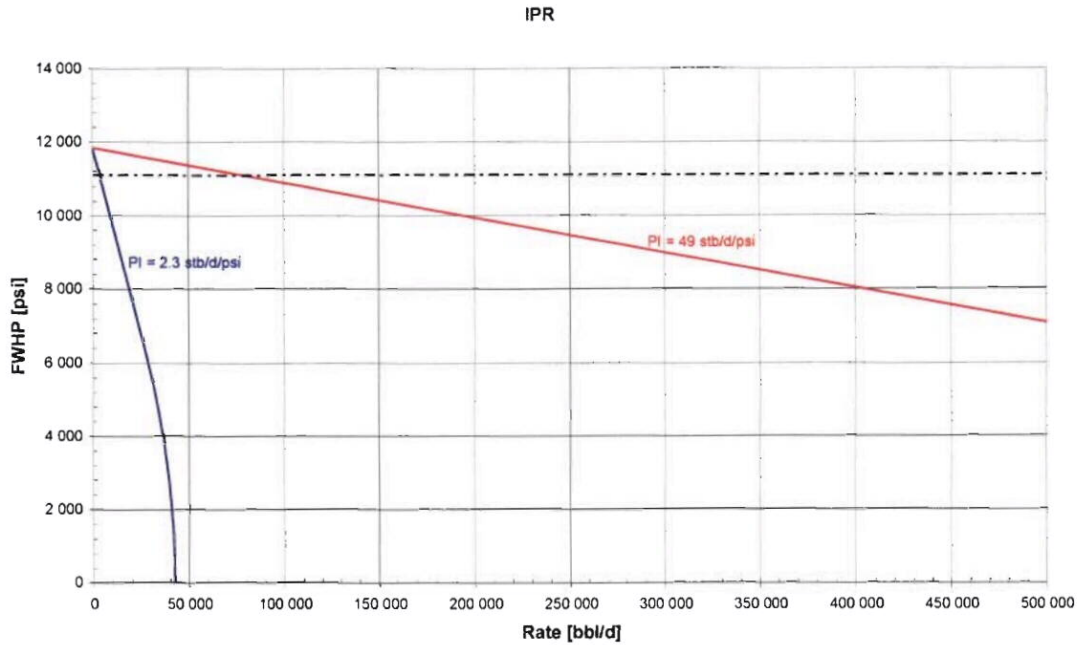

Figure 3.5: Inflow performance curves at reservoir conditions based on 4 ft and 86 ft of 300 mD sand

3.3 Compressibility of the 14 ppg mud

Two observations are made with respect to the compressibility of the 14 ppg mud. The first was during the attempts to convert the float on April 19th between 14:30 hrs and 17:30 hrs. It took nine attempts before the float was converted, the associated pressures and volumes were recorded (see Table 3.1).

Table 3.1: Float conversion attempts

Attempt No	Total volume [bbl]	From [psi]	To [psi]	Volume [bbl]	Comp. [1/psi]
#4	886	0	2000	6.7	3.78E-06
#5	886	0	2000	6.6	3.72E-06
#7	886	0	2250	7.3	3.66E-06
#8	886	0	2500	7.8	3.52E-06
Average					3.67E-06

In addition to these attempts, a casing pressure test was performed April 20th between 11:06 hrs and 11:17 hrs (see Table 3.2).

Table 3.2: Casing pressure test

Test	Total volume [bbl]	From [psi]	To [psi]	Volume [bbl]	Comp. [1/psi]
Casing	758	234	2617	6.1	3.13E-06

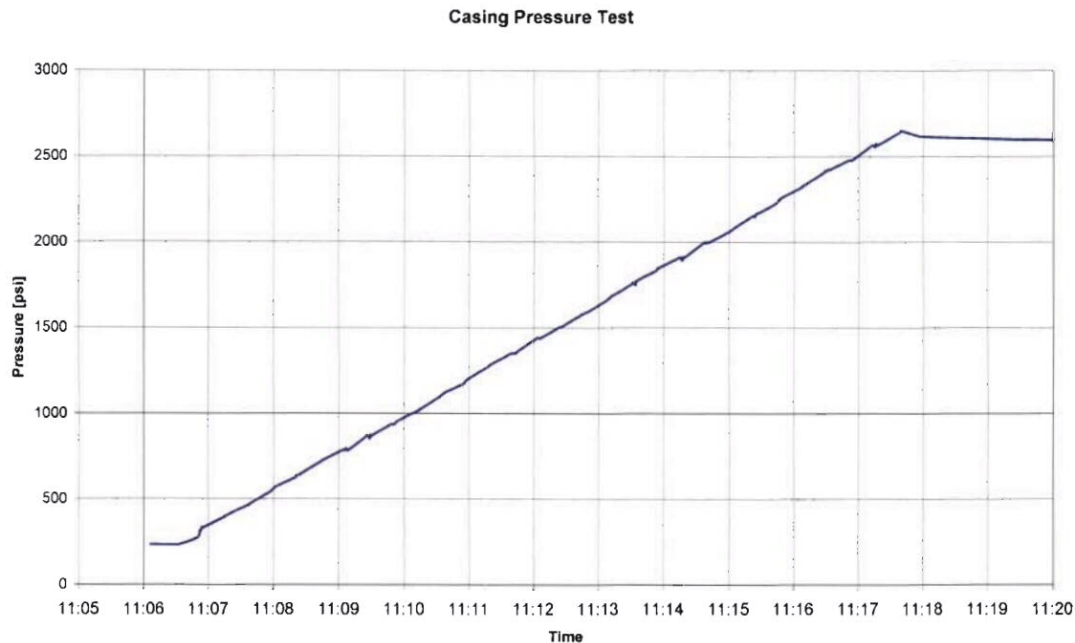

Figure 3.6: Casing pressure test from 234 psi to 2617 psi (6.0 bbl)

The compressibility is a measure of how much incremental fluid is required to pressurize fluid contained in a fixed volume by a certain amount of psi.

$$k = \frac{\partial V}{V \cdot \partial P}$$

The outer annulus measures approximately 1,100 bbl, and by using the average number from the float conversion attempts (3.67E-06), approximately 10 bbl will be expected to be bled back from this volume when decreasing the pressure from 2,400 to 250 psi.

The reported gains (60 – 85 bbls) during the negative test bleed downs were higher than what could be expected due to the compressibility of the mud. Some of this discrepancy (50 – 60 bbls) was explained by a leaking BOP annular and some can be explained by the compressibility of the mud. It is possible that an influx of between 0 to 20 bbls of hydrocarbon occurred during the negative test bleed downs.

3.4 Blowout potentials

Estimation of the well's flowing potential is important for the determination of the events leading up to the explosion. This analysis of the blowout potential attempts to simulate the conditions around the time of the incident and does not estimate the potential flow rate after the incident, which would depend on additional unknown factors which were not considered, such as restrictions in the BOP, limited reservoir exposure etc. The estimated blowout potential for several different scenarios are listed in Table 3.3, all based on comingled flow from the 12.6 ppg oil reservoirs with an average permeability of 300 mD. It is assumed that the flow is exiting through both the riser and through the drill pipe without any restrictions.

The highest flow potential is through the production casing. The outer annulus of the production casing has some narrow sections (between the 9 7/8" casing and the 7" casing) and this will create more frictional forces and higher pressure drop.

Table 3.4 (flow at surface) and Table 3.5 (flow at seabed) show the distribution of flow between the drill pipe and the riser for the scenario of flow through the production casing. In addition, the total flow potential based on a blocked drill pipe and flow in the riser only, and a sealed BOP and flow in the drill pipe only, are included.

Figure 3.7 shows flow rates in stb/d for flow through the production casing shoe versus increasing net pay, it is assumed that flow is unrestricted and flowing through both the riser and the drill pipe simultaneously. There are two plots on the chart, one showing the flow rate to surface and the other showing the flow rate at the seabed.

Figure 3.8 shows flow rates in stb/d for flow through the production casing shoe versus increasing net pay, it is assumed that flow is unrestricted and flowing just through the drill pipe. There are two plots on the chart, one showing the flow rate to surface and the other showing the flow rate at the seabed.

Simulations were also performed for the blowouts to seabed with restrictions in the BOP. By including a restriction resulting in a flowing wellhead pressure of 3800 psi, the flow potential decrease by approximately 10 %. From 61 000 stb/d to 54 000 stb/d inside the casing using 86 ft pay zone and assuming flow through the casing shoe. By using a wellhead pressure of 3000 psi, the flow rate reduces to 58 000 stb/d. See Figure 3.9.

Table 3.3: Blowout potential versus flow path, net pay and exit point

Flow path	Outer annulus [stb/d]		Casing [stb/d]	
	Surface	Seabed	Surface	Seabed
4 ft net pay	17 500	14 000	18 000	15 000
86 ft net pay	47 000	43 000	68 000	67 000

Table 3.4: Distribution of flow for casing scenario to surface

Flow path	Casing [stb/d]				
	Drill pipe	Riser	Total	Only Riser	Only DP
4 ft net pay	4 500	13 500	18 000	18 000	15 000
86 ft net pay	21 000	47 000	68 000	61 000	36 000

Table 3.5: Distribution of flow for casing scenario to seabed

Flow path	Casing [stb/d]				
	Drill pipe	Riser	Total	Only Riser	Only DP
4 ft net pay	3 800	11 200	15 000	15 000	13 500
86 ft net pay	19 500	47 500	67 000	61 000	40 000

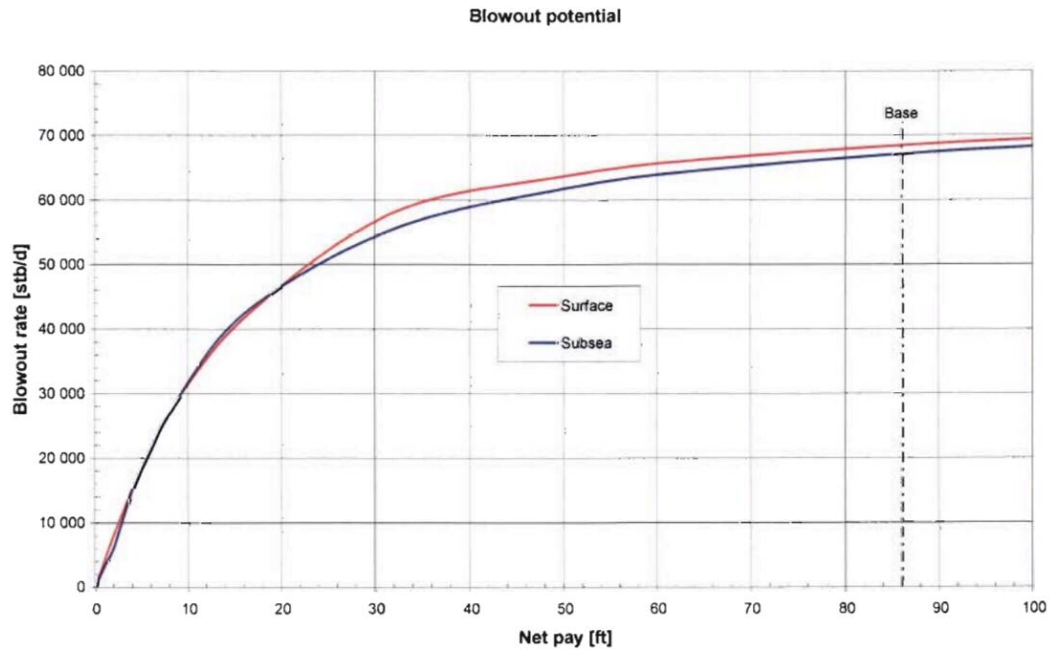

Figure 3.7: Blowout potential with flow from shoe through the drill pipe and riser

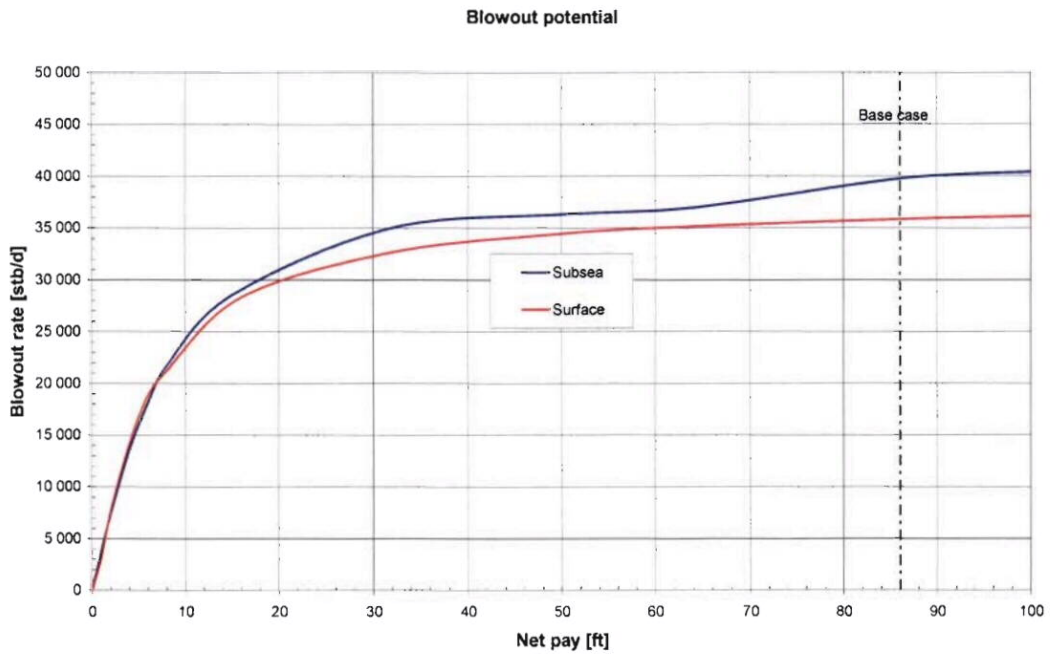

Figure 3.8: Blowout potential with flow from the shoe through drill pipe only

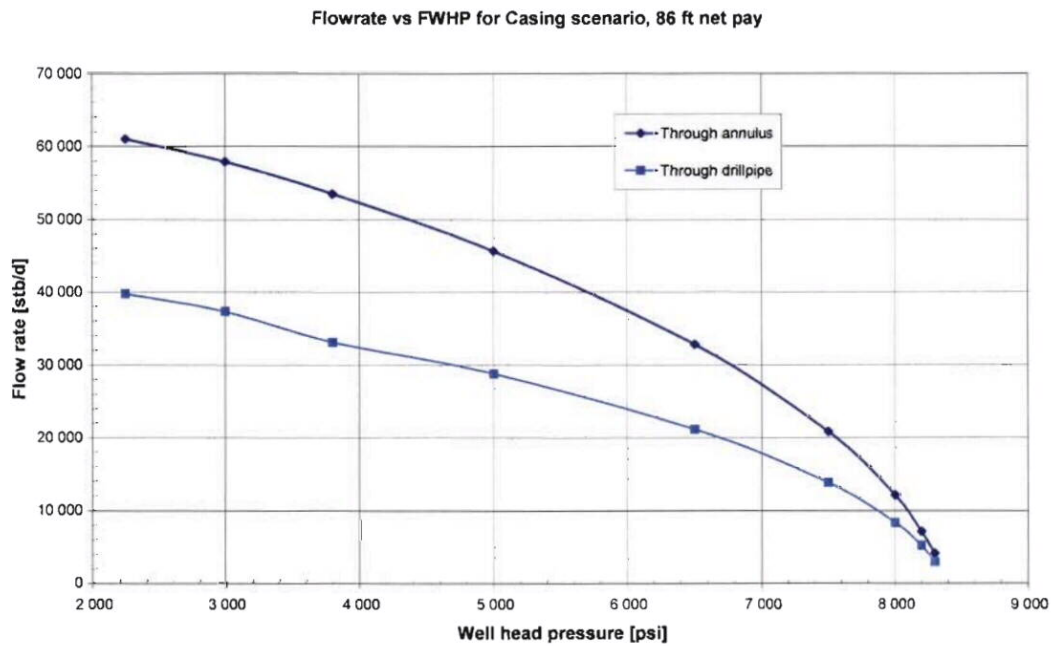

Figure 3.9: Blowout potential through the casing shoe versus FWHP

3.5 Shut-in pressures with hydrocarbons in the wellbore

If the well (full of hydrocarbons) is shut-in at surface, the estimated shut-in pressure is 6,800 psi. If the well (full of hydrocarbons) is shut-in at the seabed, the shut-in pressure is estimated to be 8,250 psi. Both pressures are above the bubble point pressure, therefore, no gas will be present when equilibrium is obtained after a long shut-in period.

Depending on the flowrate and temperature profile in the well prior to the shut-in, the simulations indicate that the peak pressures can be slightly higher than the reported settle out pressures. Examples of a subsea shut-in are shown in Figure 3.10. For a potential shut-in at surface the pressure buildups will be slower due to more gas in the wellbore.

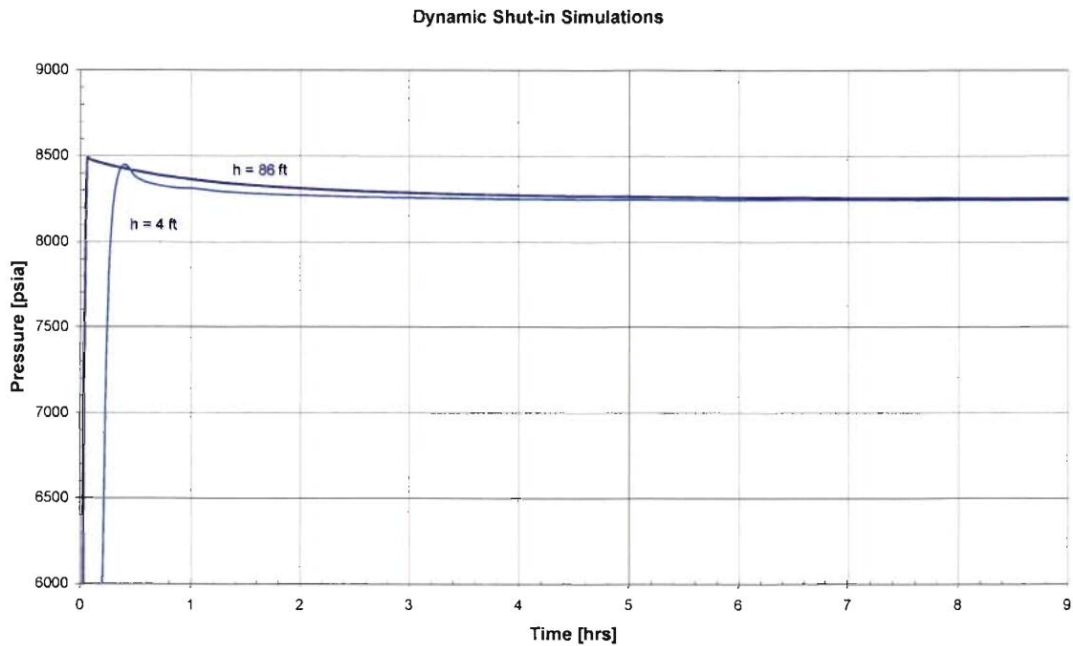

Figure 3.10: Examples of dynamic shut-in pressures, shut-in at seabed

3.6 Early Simulations

3.6.1 Introduction

During the negative test bleed downs, the pressure at down hole conditions dropped below the pore pressure and early in the investigation, a gain of 60 to 85 bbls was believed to have been taken. Simulations were performed assuming 12.6 ppg sand, an 85 bbl hydrocarbon influx during the negative test and 86 ft net pay. The results of these simulations are shown for:

- flow through the production casing (see Case 1 in Section 3.6.2)
- flow through the outer annulus of the production casing (see Case 2 in Section 3.6.3).

Neither of these initial simulations, which are based on the entire reservoir (86 ft net pay), being open to flow, gave a perfect match with actual events and recorded data. However, they are included in this report for completeness and they provided the foundation for the subsequent modeling that was completed.

A third case, (see Case 3 Section 3.6.5) simulates the effect of 4 ft of 13 ppg sand.

When witness accounts became available to the investigation team, it became evident that the assumed gain of 60 to 85 bbls during the negative test was primarily accounted for by a leaking BOP annular. The riser is believed to have been topped up with 50-60 bbls during this period due to the leaking BOP annular. Hence, no or only a small influx (0 - 20 bbls) was taken during the bleed downs during the negative test. This information changed the premise significantly with respect to identifying the flow path. Without the 85 bbls of initial hydrocarbon influx, close match simulations for flow through the outer annular of the production casing and up through the seal assembly can not be created even when using a net pay of 86 ft.

3.6.2 Case 1 - Flow through casing assuming 12.6 ppg sand and 86 ft reservoir exposure.

This case was based on early suggestions of a potential 85 bbl gain during the negative test. This case assumes 12.6 ppg reservoir pressure and 86 ft net pay (i.e. full reservoir exposure). The flow path is through the casing. Results of this simulation are shown in Figure 3.11 and Figure 3.12.

The results show a fair match of drill pipe pressure until about 21:00 hrs. However, the modeled shut-in pressures do not match the recorded data. According to the simulations, the shut-in pressure at 17:20 hrs is 200 psi lower than the recorded pressure. Further, the results indicate that the unloading of the wellbore is occurring quite fast (less than one hour). The arrival of the hydrocarbons to surface occurs too early, it is predicted that hydrocarbons will reach surface at approximately 21:15 hrs, almost 30 minutes earlier than what the witness accounts indicate. It is concluded that a lower net pay input assumption would better align with the witnessed arrival of hydrocarbons at surface. The 200 psi offset in pressure also needs to be understood.

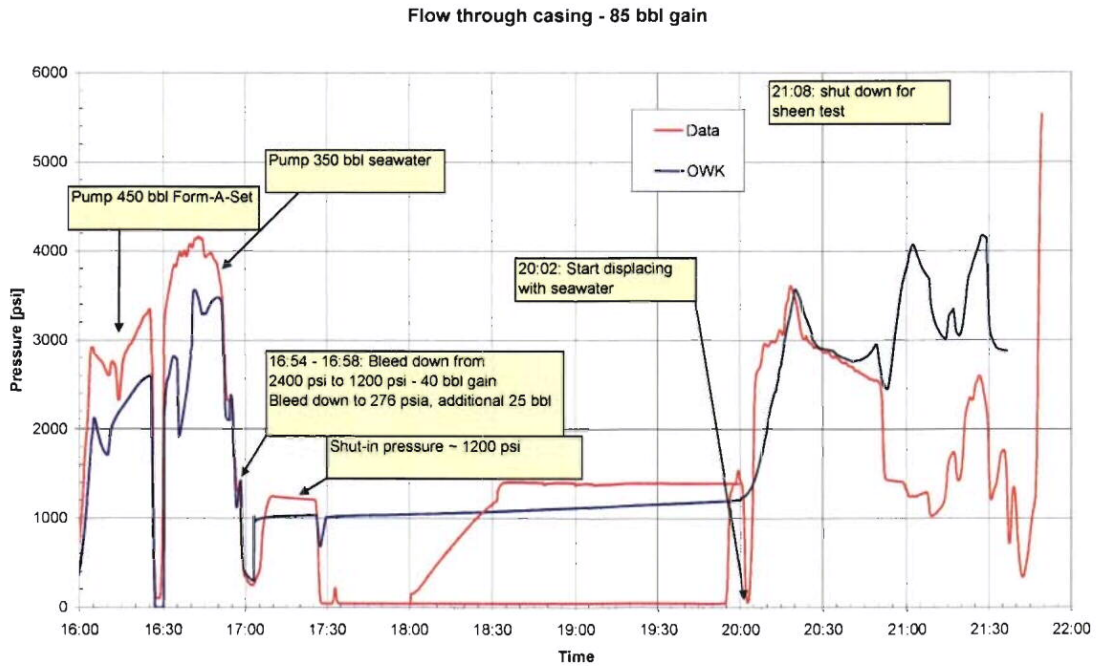

Figure 3.11: Case 1 - Flow through the casing assuming 12.6 ppg sand and 86 ft reservoir exposure. Simulated versus recorded drill pipe pressure

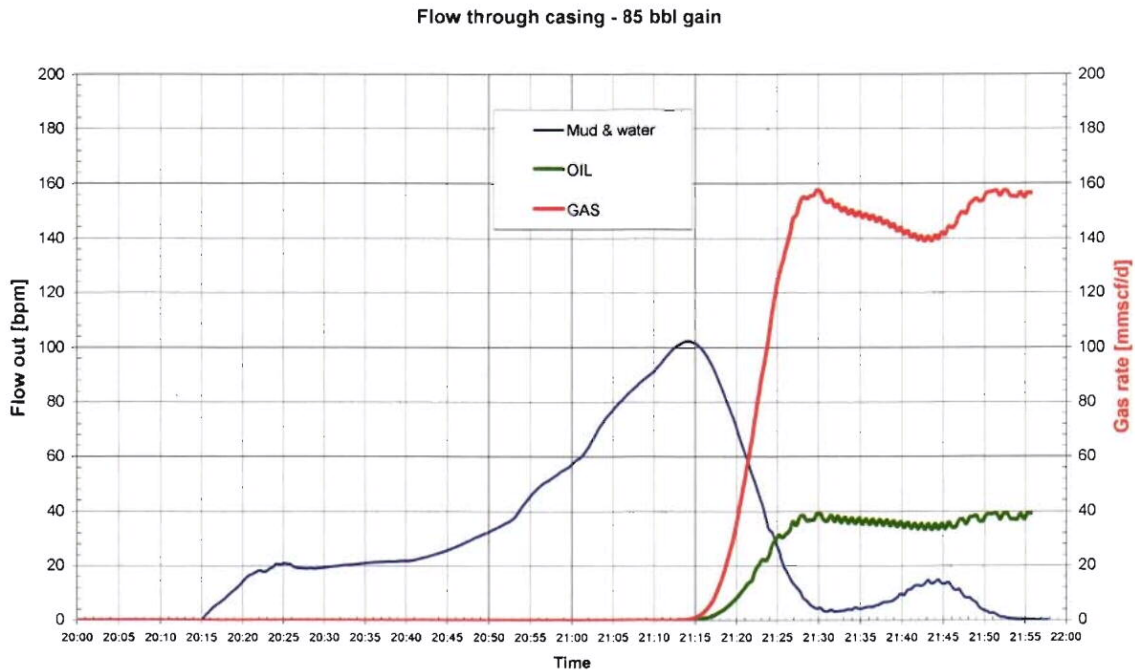

Figure 3.12: Case 1 - Flow through the casing assuming 12.6 ppg sand and 86 ft reservoir exposure. Simulated flow rates at surface

3.6.3 Case 2 - Flow through outer annulus assuming 12.6 ppg sand and full reservoir exposure.

Case 2 was based on early suggestions of a potential 85 bbl gain during the negative test. This case assumes 12.6 ppg reservoir pressure and 86 ft net pay (i.e. full reservoir exposure). The modeled flow path is through the outer annulus of the production casing. Results of this simulation are shown in Figure 3.13 and Figure 3.14.

The results of this simulation indicate that the calculated shut-in pressures are higher than the recorded. At the very end of the unloading sequence, this scenario shows a better match with the actual events compared to the casing scenario as hydrocarbons arrive at surface at about the expected time. However:

- the last two pressure buildups can only be reproduced by inclusion of a restriction in the flow path. This does not align with witness accounts of the BOP being activated after 21:41 hrs.
- during the sheen test the pressure is dropping instead of increasing as in the recorded data.

It is therefore concluded that this scenario does not adequately match the actual events or recorded data. Moreover, when the 85 bbl hydrocarbon influx is discounted, which was originally assumed to have been taken during the negative test, the scenario of flow through the casing outer annulus and the seal assembly is no longer plausible. Even on the basis that the full 86 ft of net pay is open to flow, which in itself is less likely, hydrocarbons do not arrive at surface in time to match witnessed events. It is therefore concluded that it is very unlikely that the initial flow came through the outer annulus of the production casing and through the seal assembly.

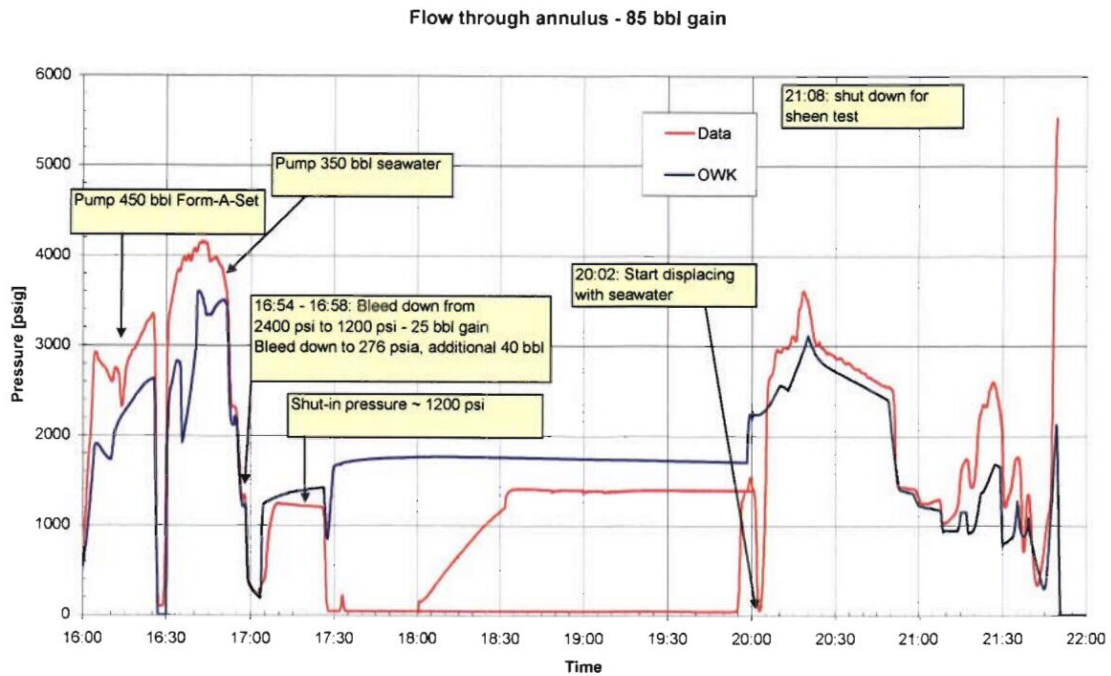

Figure 3.13: Case 2 - Flow through the outer annulus assuming 12.6 ppg sand and 86 ft reservoir exposure. Simulated versus recorded drill pipe pressure

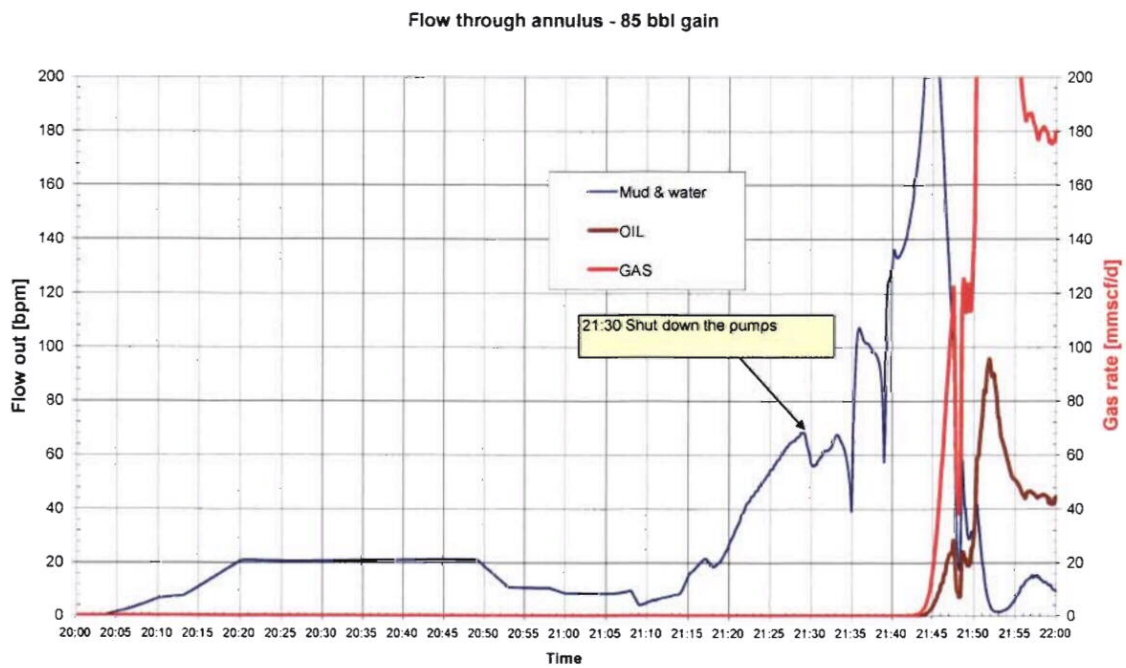

Figure 3.14: Case 2 - Flow through the outer annulus assuming 12.6 ppg sand and 86 ft reservoir exposure. Simulated flow rates at surface

3.6.4 Shut-in pressure considerations

Two shut-in periods during the negative test were used to estimate the downhole conditions and size of a potential kick by static considerations. During the period between 17:10 hrs and 17:25 hrs, the shut-in pressure was approximately 1,200 psi. During the period between 18:34 hrs and 19:57 hrs the shut-in pressure was approximately 1,400 psi.

As discussed previously, early interpretations of the bleed-downs through the drill pipe suggested an 85 bbl gain caused by an influx from the reservoir. This would force mud or water up in the drill pipe and volume calculations can determine the mud water/level in the drill pipe.

Based on the 12.6 ppg pore pressure, there is a significant difference between the kick volume required to create these shut-in pressures. It will take 190 bbl inside the casing to end up with 1,200 psi shut-in drill pipe pressure whilst it will only take 25 bbl in the outer annulus. This is observed from the initial simulation runs where the inside casing scenario ended up with a shut-in pressure of 1,000 psi based on a 85 bbl kick (see Figure 3.11).

For the outer annulus scenario, simulations showed a shut-in pressure of 1,400 psi based on an 85 bbl kick, compared to the recorded 1,200 psi (see Figure 3.13). Unknown conditions down hole also challenge these calculations as the pressure depends on several factors including the extent of any cement barrier.

The difference in shut-in pressures for the two flow path scenarios is caused by the different fluids present in the two paths. For the casing scenario, there is initially water in the drill pipe to 8,367 ft, and 14 ppg mud from this point to TD. For the outer annulus, there is 14 ppg mud from the bottom of the well up to the seal assembly at the mudline, 16 ppg spacer and water in the production casing, and water in the drill pipe (see Figure 3.15).

The investigation team subsequently concluded that during the period between 17:10 hrs and 17:25 hrs the BOP annular preventer was leaking. Therefore, the 1200 psi shut-in pressure can be discounted as the drill pipe was still in communication with the fluid in the riser. Furthermore, the 85 bbl gain can also be discounted.

If it is assumed that no influx was taken during the negative test, the resulting drill pipe shut-in pressure would be:

- 1,030 psi based on a 12.6 ppg sand if communication was through the casing shoe
- 600 psi based on a 12.6 ppg sand if communication was through the seal assembly

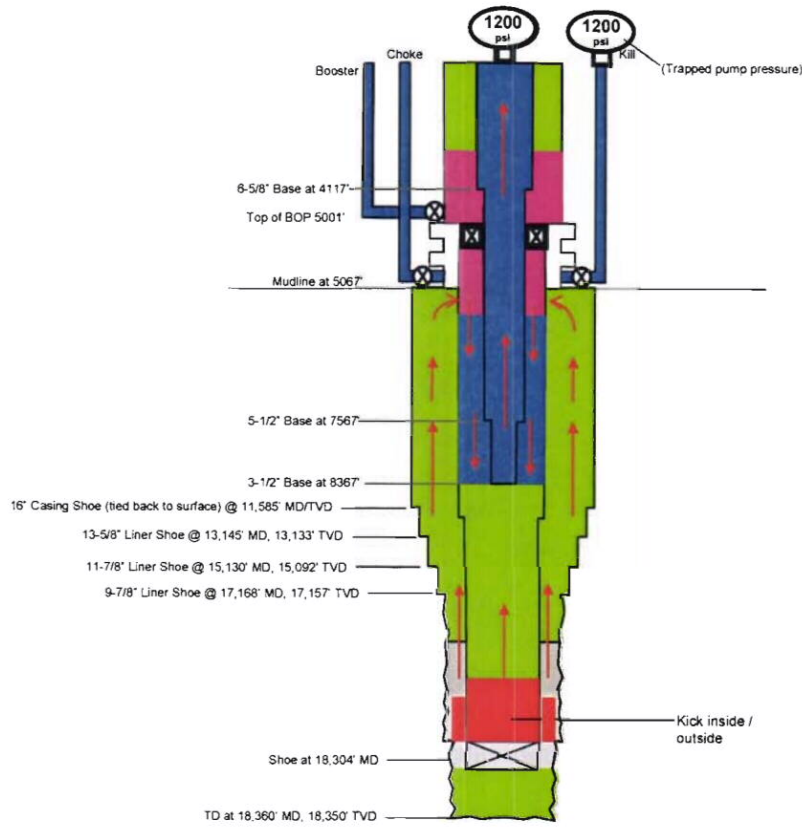

Figure 3.15: Kick and shut-in pressures

As shown in Figure 3.16, if communication was through the casing shoe, the pore pressure would need to be 13 ppg to reach 1,400 psi. There is a 13 ppg sand in the reservoir section and therefore it is concluded that this sand probably caused the 1400 psi pressure response during the negative test by transmitting pressure through the casing shoe.

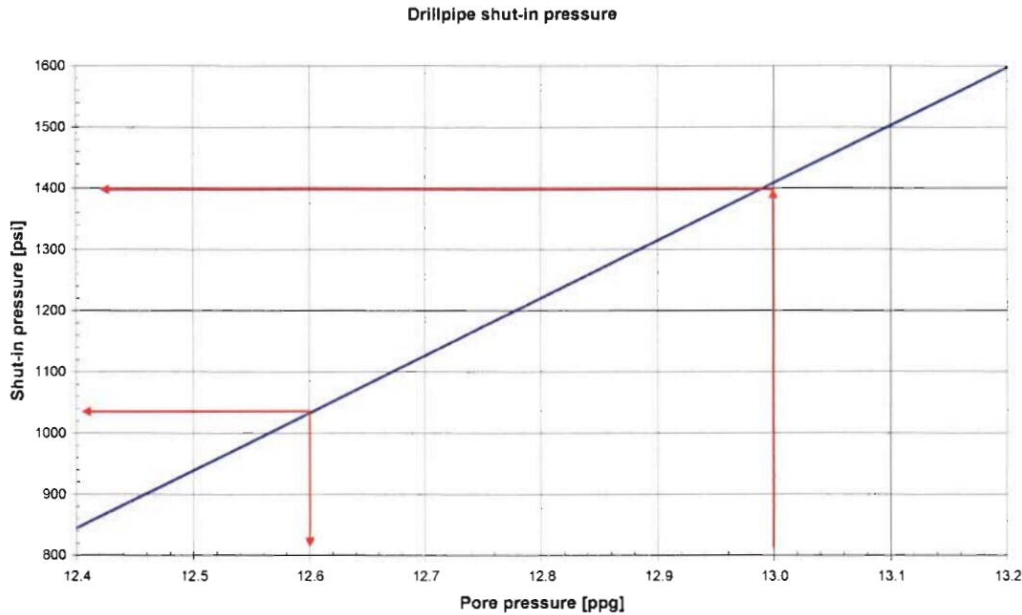

Figure 3.16: Shut-in pressures with no hydrocarbons and seawater in drill pipe

3.6.5 Case 3 - Flow through casing assuming 13 ppg sand and 4 ft reservoir exposure.

The shut-in pressure based on a 12.6 ppg pressurized sand did not match the recorded drill pipe pressure, and a new simulation was performed assuming that a 13 ppg sand was exposed to the wellbore. However, this sand has only 4 ft of net pay and the oil and gas flow rates will therefore be lower and it is expected that the hydrocarbons will arrive at surface later than what was simulated using the 86 ft of the 12.6 ppg scenario.

For this simulation, the estimated gain based on the simulations was approximately 60 bbl. The calculated shut-in pressure after the 2,400 – 250 psi bleed down was above the observed pressure of 1,200 psi, but showed a good match with the 1,400 psi shut-in pressure (see Figure 3.17). The estimated unloading sequence was in relatively good agreement with the observations (see Figure 3.18) and gas arrives at surface at about 21:45 hrs. However, the gas volumes at surface are unlikely to be adequate to cause the scale of events (explosions and fire) as portrayed in the witness accounts.

If the 13 ppg sand is able to flow it is probable that other sands will also be open to flow. As the down hole pressure reaches the point where the 12.6 ppg sands become underbalanced flow is likely to initiate from these sands, particularly in the case where the flow path is assumed to be through the production casing shoe. It is therefore concluded that, the 13 ppg sand probably caused the initial pressure increase of 1,400 psi seen during the negative test but other sands will have contributed to the flow from the well once they became underbalanced.

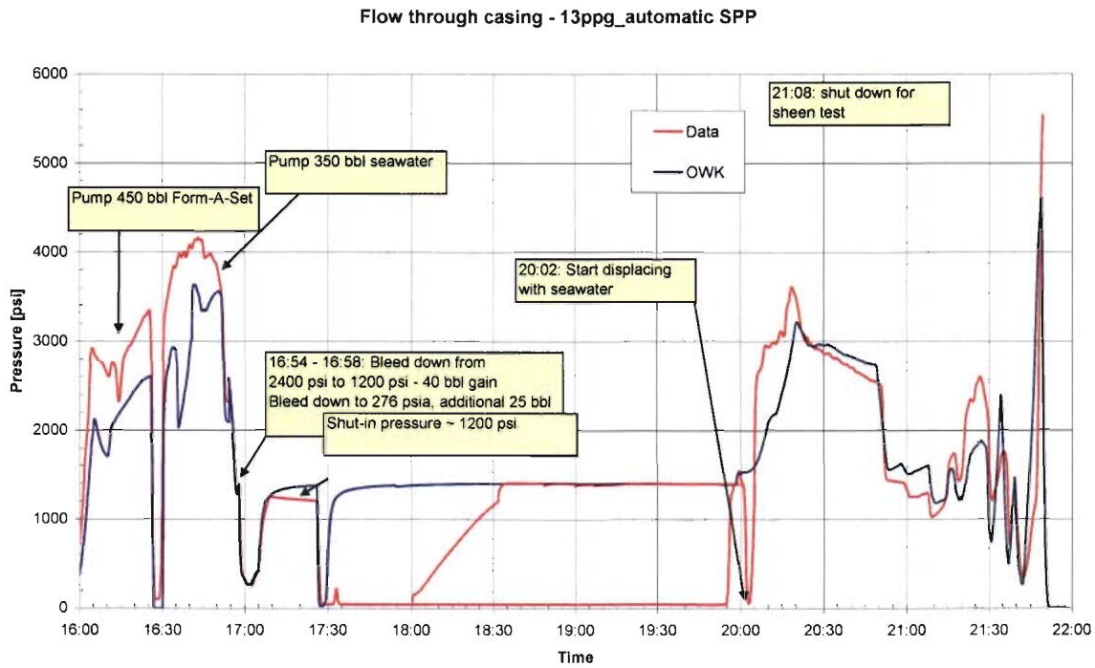

Figure 3.17: Case 3 - Flow through the casing assuming 13.0 ppg sand and 4 ft reservoir exposure. Simulated versus recorded drill pipe pressure.

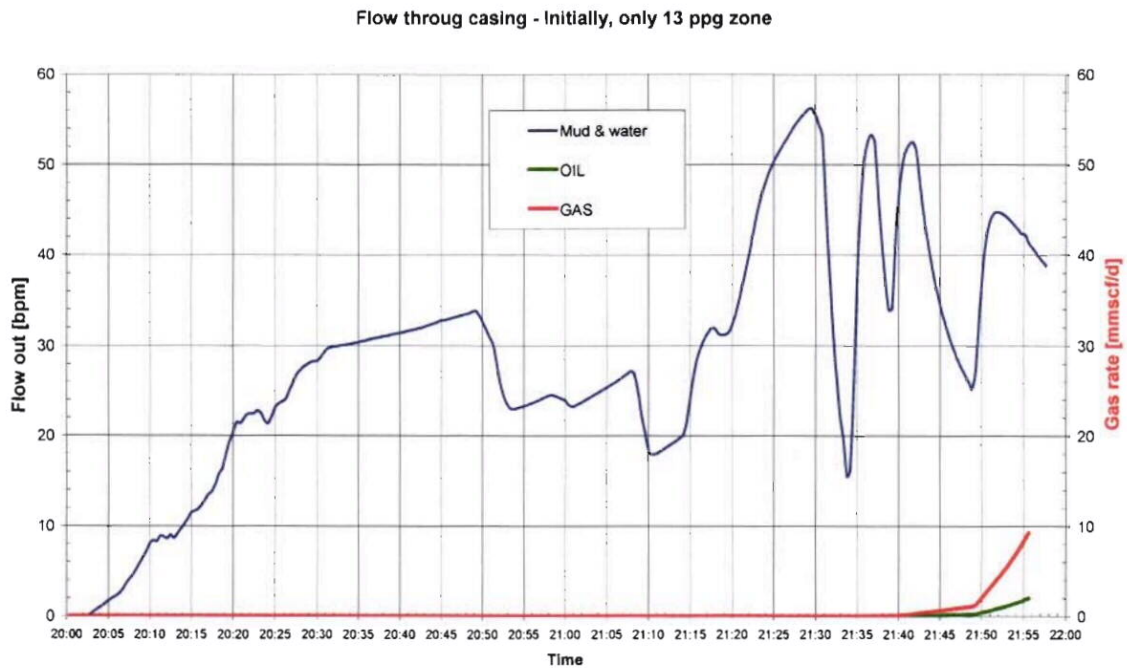

Figure 3.18: Case 3 - Flow through the casing assuming 13.0 ppg sand and 4 ft reservoir exposure. Simulated flow rates at surface.

3.6.6 Discussion on Cases 1-3

The constant shut-in pressure of 1,400 psi measured on the drill pipe between 18:35 hrs and 20:00 hrs cannot be explained based on a pore pressure of 12.6 ppg and the conclusion from the investigation team of a much smaller influx (0 - 20 bbls) during the negative test. Assuming zero hydrocarbon influx, mud in the wellbore and seawater in the drill pipe, the shut-in pressure should be 1,030 psi if communication to the reservoir was through the casing shoe, and only 600 psi if communication was through the seal assembly. However, a sand pressurized at 13.0 ppg matches the observed 1,400 psi shut-in if the reservoir pressure is communicated through the shoe. If the pressure is communicated from a 13.0 ppg sand through the outer annulus, the resulting shut-in pressure is still too low.

3.7 Final Simulations

3.7.1 Introduction

Witness accounts indicate that the riser was topped up with approximately 50 bbls of mud between 17:12 hrs and 17:22 hrs and therefore most of the bleed volumes witnessed during the negative test were most likely caused by a leak in the annular preventer. This information combined with insights gained in our first series of simulations guided us to focus our Final Simulations assuming the following:

- no influx during the negative test
- net pay between 13 ft and 16.5 ft of 12.6 ppg sand.

Case 4 includes a final simulation for flow through the production casing outer annulus and comes to the conclusion that flow through the shoe is the most credible scenario. Cases 5, 6 and 7 are all based on flow through the production casing and Case 7 is the final simulation run, the investigation team uses Case 7 to support several elements of their analysis in the investigation report.

3.7.2 Case 4 - No influx prior to 20:02 hrs, 15 ft net pay of 12.6 ppg sand and flow through outer annulus and casing shoe.

Case 4 assumes 12.6 ppg reservoir pressure and 15 ft net pay. Further, it is assumed that the well was fully filled with water, spacer and mud and that no influx was taken before the circulation at 20:02 hrs .

When circulation starts, the pump pressure and the bottom hole pressure increase. At 21:08 hrs, the pumps are stopped for a sheen test, and the drill pipe pressure is 1,000 psi, but increasing. At this point in time, 1,300 bbl of water has been pumped, and both the drill pipe and the volume between the drill pipe and 9 7/8" casing up to the seabed is filled with water. The pump rate has ranged between 500 and 1,250 gpm (see Figure 3.20) and this is sufficient to obtain effective transportation and displacement of the fluids up through the production casing (between the drill pipe and 9 7/8" casing). The production casing is therefore fully displaced to seawater above the bottom of the drill pipe and into the riser at 21:08 hrs.

At 21:08 hrs, the calculated average fluid density at the formation via the outer annulus of the production casing is equivalent to 13.6 ppg. The reservoir would be overbalanced and no influx can be taken. This is because the annulus of the production casing is full of 14 ppg mud all the way up to the seal assembly.

Figure 3.19 shows a linear static pressure profile in the well with 1,000 psi drill pipe pressure, seawater in the drill pipe, seawater in the production casing above the bottom of the drill pipe and 14 ppg mud in the production casing outer annulus below the seal assembly. In order to balance a 13 ppg sand at 17,800 ft based on this condition, the top of the hydrocarbon influx should be at 16,700 ft (see Figure 3.19). This requires a 25 bbl influx assuming that the top of the cement is at 17,450 ft, with only smaller channels below to the 13 ppg sand.

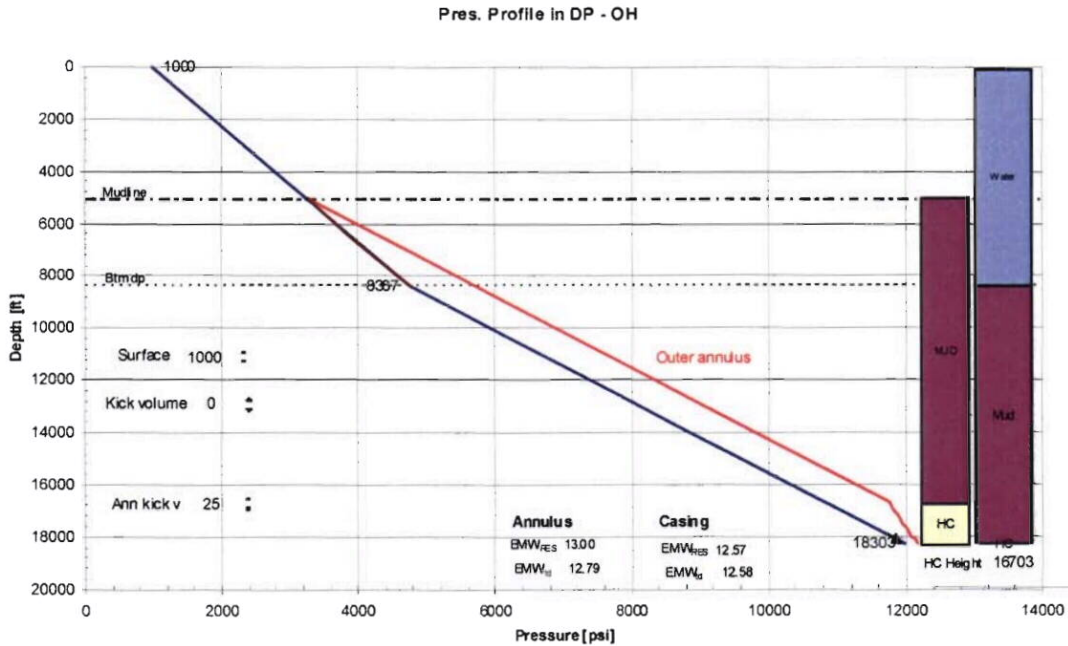

Figure 3.19: Pressure profile in outer annulus to balance 13 ppg sand

At 21:08 hrs, the calculated average fluid density at the formation via the production casing is less than 12.6 ppg and therefore the flow path through the production casing is in an underbalanced condition. The investigation team calculated that a 39 bbl gain was taken between 20:52 hrs and 21:08 hrs, it is concluded that the influx is coming via the production casing shoe.

The simulation through the casing shoe shows a fairly good match with the recorded drill pipe pressure during the circulation job until the pumps are shut down at 21:30 hrs (see Figure 3.21). However, pressure gradients appear to be steeper, for example during the sheen test period from 21:08 hrs to 21:14 hrs (see Figure 3.21); this is indicative of a higher predicted flow rate than what actually occurred. At 21:30 hrs the simulations predict a decreasing drill pipe pressure in contrast to the recorded pressure data showing several pressure peaks. This decrease in pressure is primarily caused by the lighter hydrocarbon fluid rising through the production casing past the end of the drill pipe and displacing the denser seawater.

Figure 3.21 shows the recorded drill pipe pressure versus the modeled drill pipe pressure for this case (flow through the shoe with an assumption of 15 ft net pay and 12.6 ppg pore pressure). Figure 3.22 shows plots of the surface flow rates and reservoir influx for the same case.

With the exception of the pressure response after 21:30 hrs, this case presents a close match to recorded pressure data. The simulation also provides a good predictive match with the observed timing of the actual arrival of hydrocarbons at surface. It is possible to create a pressure response match after 21:30 hrs by

simulating BOP elements closing but not fully sealing; this analysis is detailed under Case 6 in Section 3.7.7. However, witness accounts suggest that BOP activation only occurred after 21:40 hrs, therefore the pressure increase from 21:31 hrs to 21:34 hrs cannot be explained by closing in the well at the BOP.

Combining all of the insights from the simulations presented so far in the report demonstrates that flow through the outer annulus of the production casing is not a credible scenario. The remaining simulations in this report consider flow through the production casing. These final simulations focus on adjusting the net pay input assumption and closure of BOP elements after 21:41 hrs.

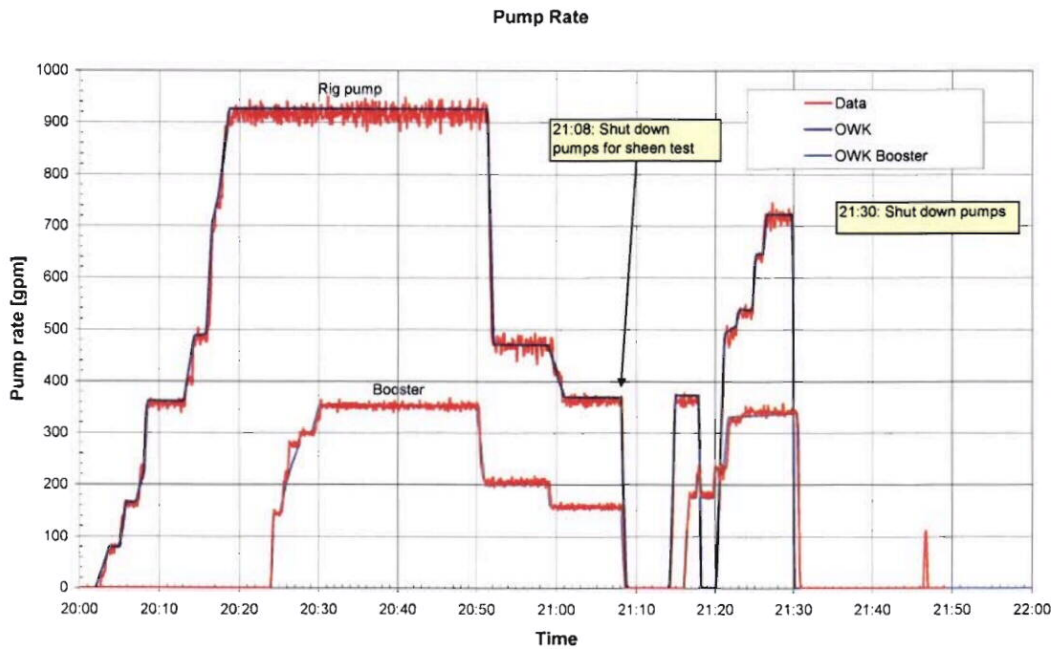

Figure 3.20: Pump schedule during the period between 20:00 hrs – 21:30 hrs.
Recorded data versus input to model

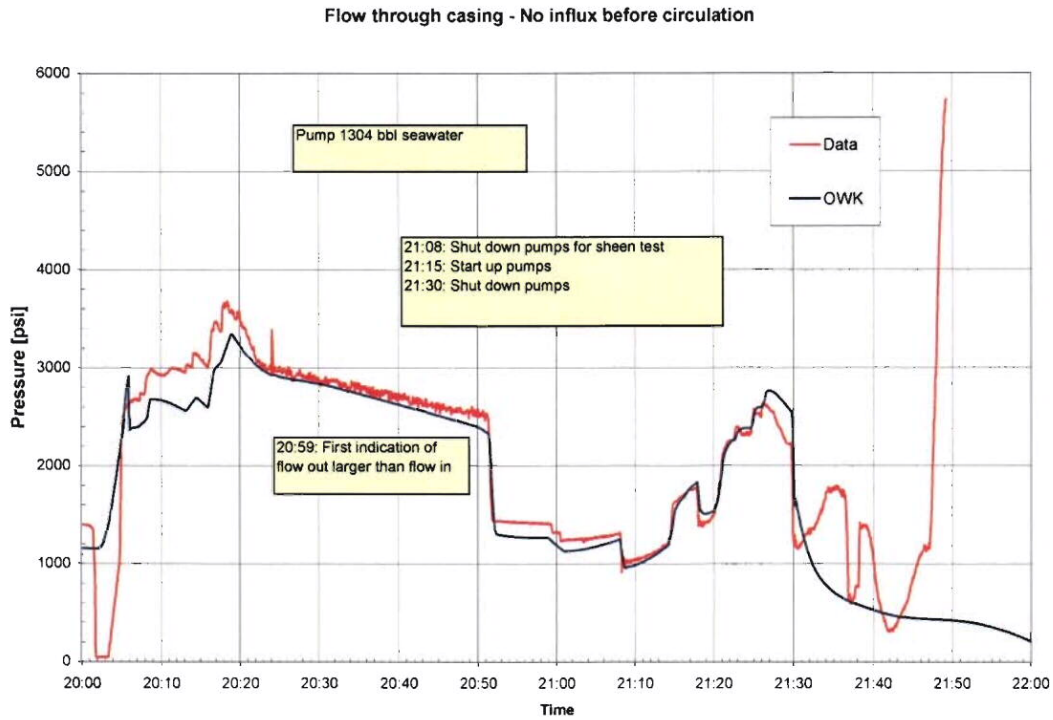

Figure 3.21: Case 4 - Flow through casing assuming 12.6 ppg sand and 15 ft reservoir exposure. Simulated versus recorded drill pipe pressure.

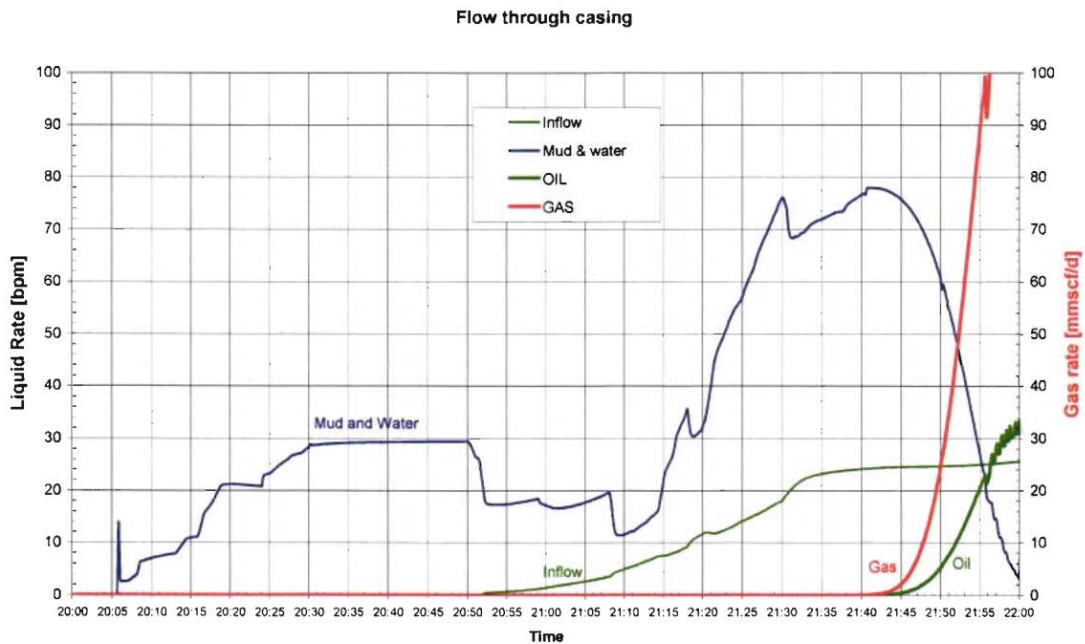

Figure 3.22: Case 4 - Flow through casing assuming 12.6 ppg sand and 15 ft reservoir exposure. Simulated flow rates at surface.

3.7.3 Pressure drop in surface lines

In order to investigate the potential surface pressure increases during the well blow-out several simulations were performed for 14 ppg mud flowing through 500 ft of horizontal line. The 500 ft line length does not reflect actual lengths of pipe on the rig but is a nominal length used in the model. These simulations were completed to gain an appreciation of the range of possible pressures for different liquid flow rates and possible surface flow paths.

The pressure drop down the 18 in line (same diameter as the main riser flow line to the mud pits) is low even with flow rates up to 300 bbl/min; this demonstrates its capacity to transport large volumes of liquid. The 14 in lines (same diameter as the main starboard and port diverter lines) can also accommodate high rates of liquid flow (see Figure 3.23).

It should be noted that these simulations do not reflect the impact of high gas and liquid flow rates occurring simultaneously at surface. Higher pressure increases would occur in this event.

The vent line from the mud gas separator is 245 ft high, which would create a hydrostatic head of 180 psi based on the 14 ppg mud. A burst disk is installed to protect the gas separator, and is supposed to pop open at 15 psi. The flow would then be routed through a 6" line overboard with the vent line still open. Also, the separator itself was not rated for high pressures.

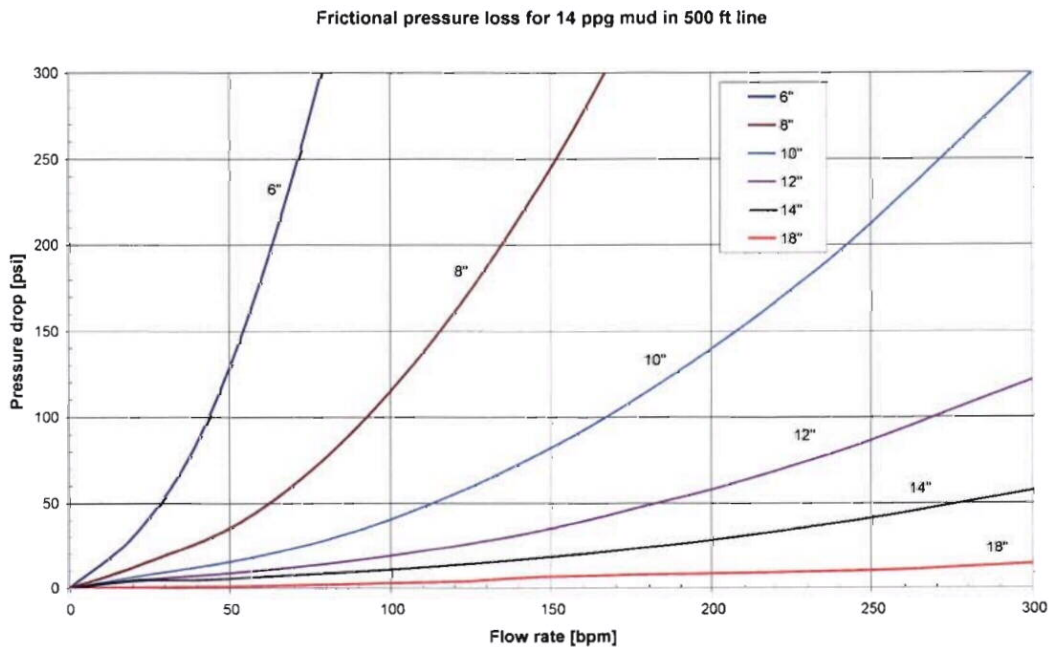

Figure 3.23: Frictional pressure loss in 500 ft pipe with 14 ppg mud

3.7.4 Pressure drop across a leaking annular BOP

Simulations were performed to investigate the pressure drop that would occur in a situation with mud flow through a leaking annular BOP between the riser and the 5 1/2" drill pipe (see schematic of an annular BOP at Figure 3.24). The total flow area of a fully open annular is 252 in², and Figure 3.25 shows the pressure drop versus opening for two fixed flow rates of 14 ppg mud. As can be seen from Figure 3.25, only minor pressure drops occur before the annular reaches a 97 % closed position.

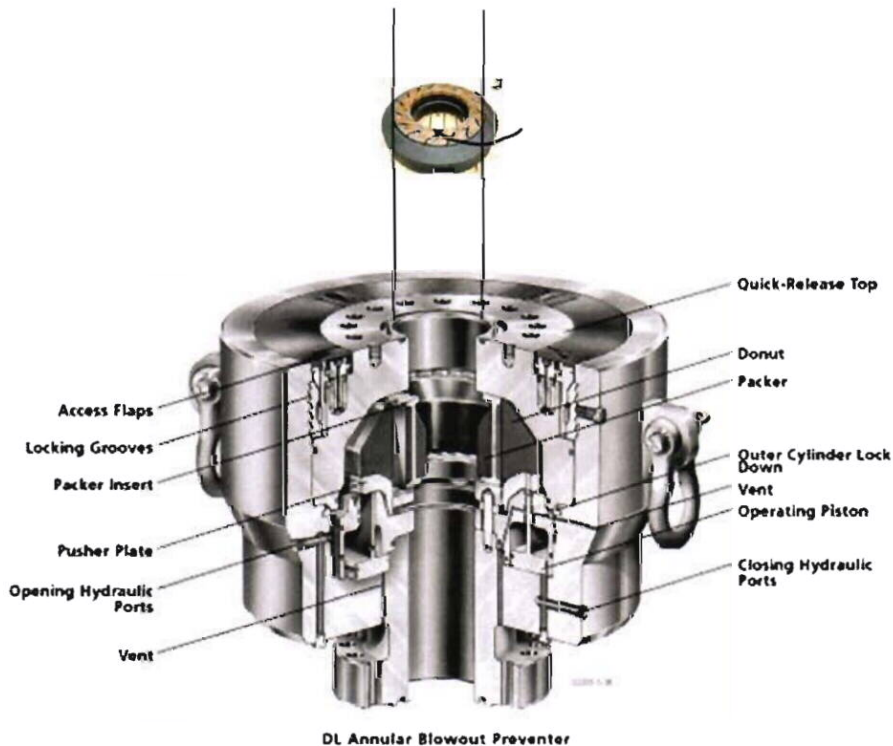

Figure 3.24: Annular blowout preventer

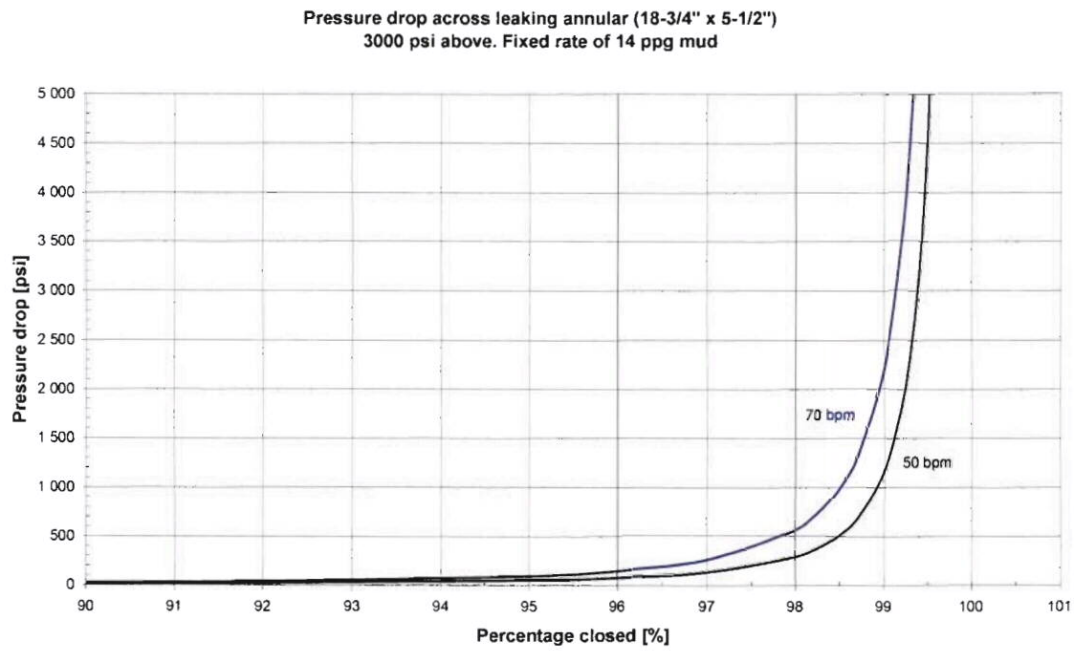

Figure 3.25: Pressure drop across BOP for various rates of BOP closure

3.7.5 Sensitivities with respect to potential events after 21:30

The actual pressure readings show fluctuations in pressure between 21:30 hrs and 21:50 hrs (see Figure 3.26). These fluctuations cannot be solely explained by the transient effects occurring in the wellbore at this time, such as variation in inflow performance, changes in wellbore fluids, gas flashing, variation in flow regime, swapping of phases etc. It is therefore believed that, down-hole restrictions in the flow path (partly sealing annular preventers), additional back pressure caused by surface piping and equipment and/or bleed back of fluids contributed to the generation of some of the observed pressure response.

Included in the simulation cases 5,6 and 7 are scenarios which explain the possible causes of these pressure fluctuations.

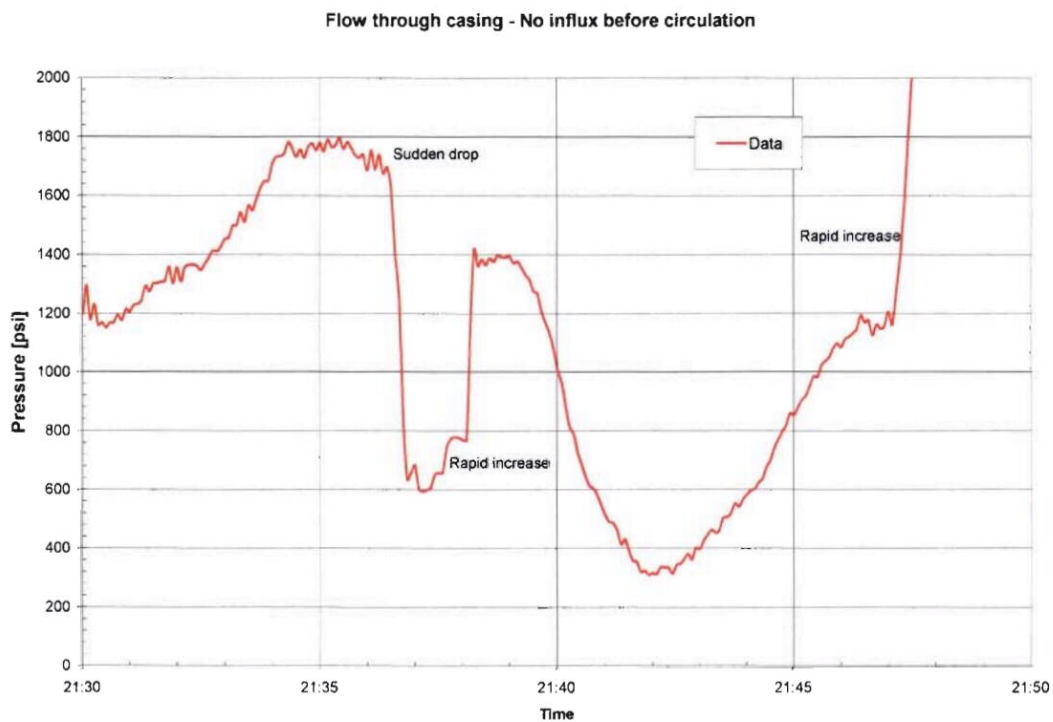

Figure 3.26: Pressure fluctuations the last minutes before explosion

3.7.6 Case 5 - Well shut-in at surface at 21:30

As in Case 4, Case 5 assumes 12.6 ppg reservoir pressure and 15 ft net pay. Further, it is assumed that the well was fully filled with water, spacer and mud and that no influx was taken before the circulation at 20:02 hrs. The flow path is through the casing shoe. This case assumes that the well is shut-in at surface at 21:30 hrs by closing the riser diverter and having no open flow path. The modeled pressure response indicates a quicker pressure buildup than shown by the recorded data (see Figure 3.27).

It is believed that an absolute maximum back pressure of 200 psi can be generated by flowing mud and water through the mud gas separator (MGS) and other surface equipment. At these surface pressures, equipment will begin to fail including the MGS vessel and the riser slip joint seals if selected in the lower pressure mode (100 psi). It is concluded that a small proportion of the pressure increase between 21:31 hrs and 21:34 hrs could be generated by back pressure at surface through the riser but it cannot explain the majority of the 610 psi increase.

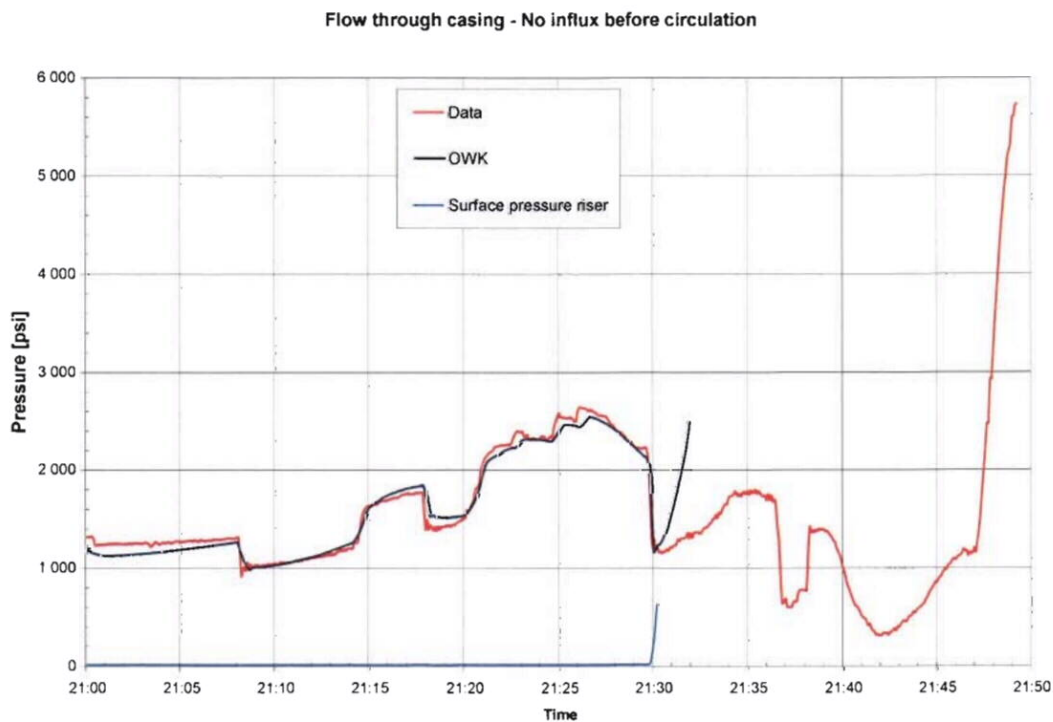

Figure 3.27: Case 5 - Pressure response for a sudden shut-in at surface (no flow)

3.7.7 Case 6 - BOP closing at 21:30 but not sealing until 21:47

As in Cases 4 and 5, Case 6 assumes 12.6 ppg reservoir pressure and 15 ft net pay. This simulation assumes that the annular of the BOP was closed but leaking from 21:31 hrs.

A fully closed and sealing BOP annular at 21:31 hrs would cause a much higher pressure increase than the recorded data shows. The simulation uses a controller to control the position of the BOP annular to allow a match with the recorded drill pipe pressure (see Figure 3.28). The annular BOP open/close sequence required to reproduce this pressure match is inconsistent with the expected crew actions or annular BOP response. However, this simulation provides some useful insights and was completed to help determine what mechanisms might have generated the recorded pressure response in the last 30 minutes.

In addition to BOP closing, scenario Case 6 also investigates potential causes of the sudden pressure drop and buildup between 21:36 hrs and 21:38 hrs. Two scenarios were tested:

- the instantaneous opening of a BOP annular.
- the bleed off of fluid from the drill pipe at surface.

The simulations suggest that the rapid pressure drop and build-up can only be generated by bleeding through the drill pipe at surface. When trying to simulate this effect mechanically at the BOP, by instantaneous opening and closing of a BOP element, the pressure transient effect created a much slower pressure response than that actually recorded (see Figure 3.29). However, as shown in Figure 3.30, the rapid pressure response could be simulated by bleeding off the drill pipe pressure at surface.

The evidence from witness accounts suggests that activation of the BOP did not occur before approximately 21:40 hrs, this is just before the second pressure increase. Hence, the first pressure increase must have been caused by mechanisms other than a partly sealing BOP annular preventer. Case 7 investigates the mechanisms that may have created the first pressure increase from 21:31 hrs to 21:34 hrs.

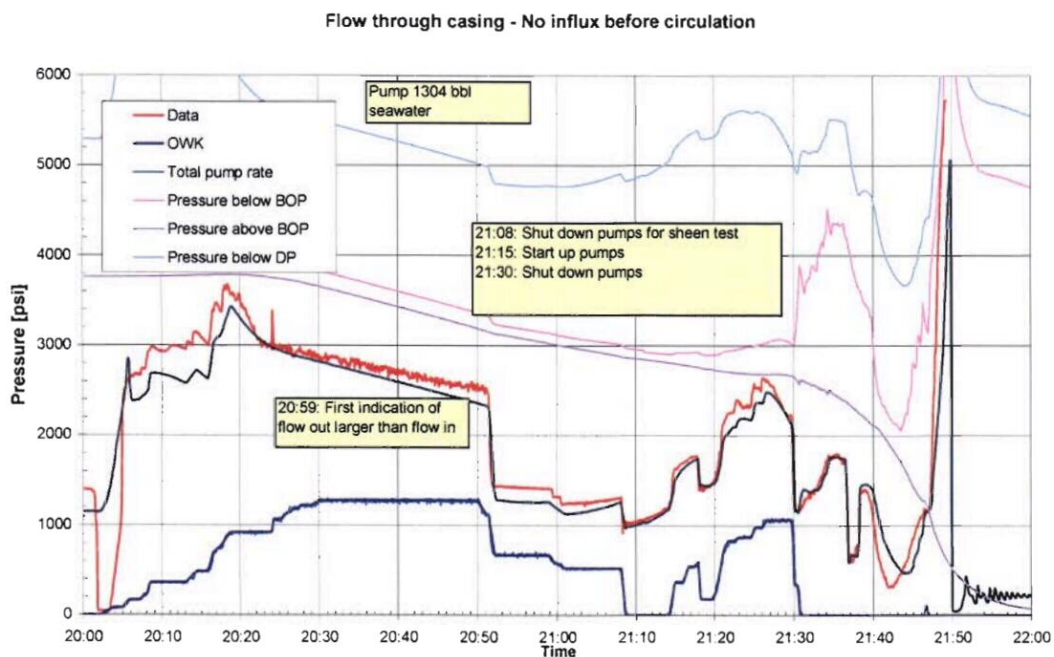

Figure 3.28: Case 6 - Simulations of circulation with flow through shoe, pressure buildups (pressure match by means of a controller).

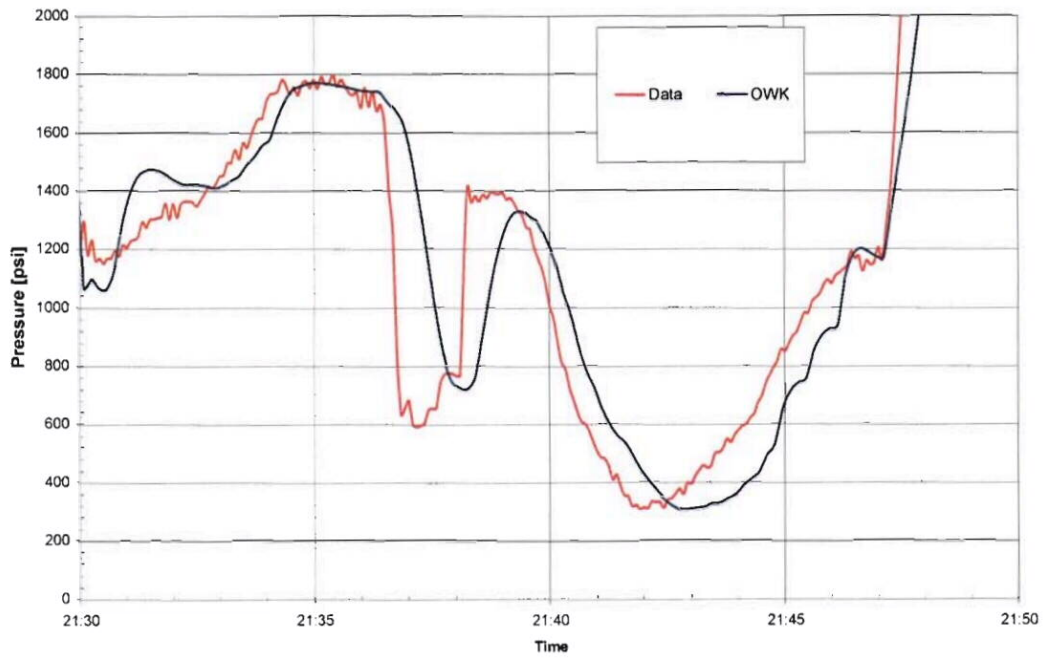

Figure 3.29: Case 6 - Simulated pressure response for an instantaneous opening of blowout preventer annular.

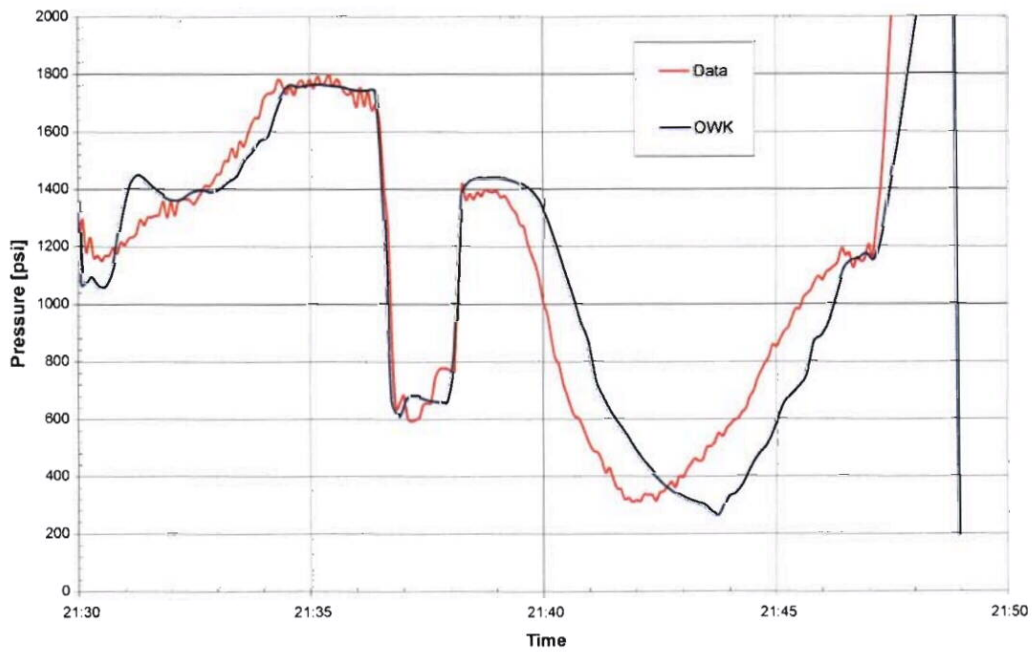

Figure 3.30: Case 6 - Simulated pressure response for a bleed back through drill pipe at surface.

3.7.8 Case 7 - BOP closed at 21:41 but not sealing until 21:47

Case 7 assumes a lower volume of hydrocarbon influx was taken prior to 21:30 hrs; this was achieved by using 13 ft of net pay of 12.6 ppg sand. When the pumps are shut down at 21:30 hrs the pressure drops creating a higher drawdown on the reservoir and from this point forward 16.5 ft of net pay is assumed in the simulation.

By slowing down the hydrocarbon influx rate there is still 14 ppg mud below the bottom of the drill pipe in the production casing at 21:30 hrs. When the mud pumps are shutdown at 21:30 hrs, the mud flows past the tail of the drill pipe replacing the lighter seawater/mud mix with 14 ppg mud. This results in an increasing drill pipe pressure due to the increasing average density above the tail of the drill pipe (see Figure 3.32).

The second increase at 21:42 hrs cannot be explained by a similar effect; by 21:42 hrs all of the mud is above the tail of the drill pipe and it is being replaced by lighter hydrocarbons. This would cause a further pressure drop and not the increase in pressure recorded (see Figure 3.31). We have only been able to explain the increase in pressure at 21:42 hrs by a closed but leaking BOP annular (see Figure 3.32). As a point of confirmation, Figure 3.32 also shows the drill pipe pressure response if the BOP annular fully sealed; a much higher pressure increase is shown than what was recorded. The assumption of a leaking BOP annular is also supported by erosion seen on the recovered drill pipe.

At 21:47 hrs it is assumed that a BOP element fully seals the well. The modeled shut-in pressure closely matches the recorded pressure (see Figure 3.32).

Figure 3.33 shows the cumulative influx of hydrocarbons and the influx rate in stb/m for Case 7.

Figure 3.34 shows the surface flow rates for Case 7. Gas arrives at surface at about 21:46 hrs and rapidly increases in rate to above 160 mmscfd, the arrival time supports the possibility of gas alarms going off about this time and the explosion occurring at about 21:49 hrs.

Figure 3.35 shows the pressures above and below the BOP for Case 7.

The nature of the transient pressure signature during the last minutes before the BOP finally seals at 21:47 hrs is challenging to determine due to several factors. The exact location of the fluid fronts will affect the observed pressure fluctuations and these will again be affected by the reservoir inflow. In the simulations, a fixed net pay has been used, but in reality, this property can change with changing down hole conditions. It is possible that initially, only smaller channels in the cement were open between reservoir and the wellbore. Later, as the drawdown increases, more of the reservoir could be exposed and hence increase the productivity.

Case 7 is the final simulation run completed in this report; this is the case that most closely matches the actual witnessed events and recorded data leading up to and during the accident. The investigation team uses the modeled outcomes from Case 7 to support several elements of their analysis in their final report.

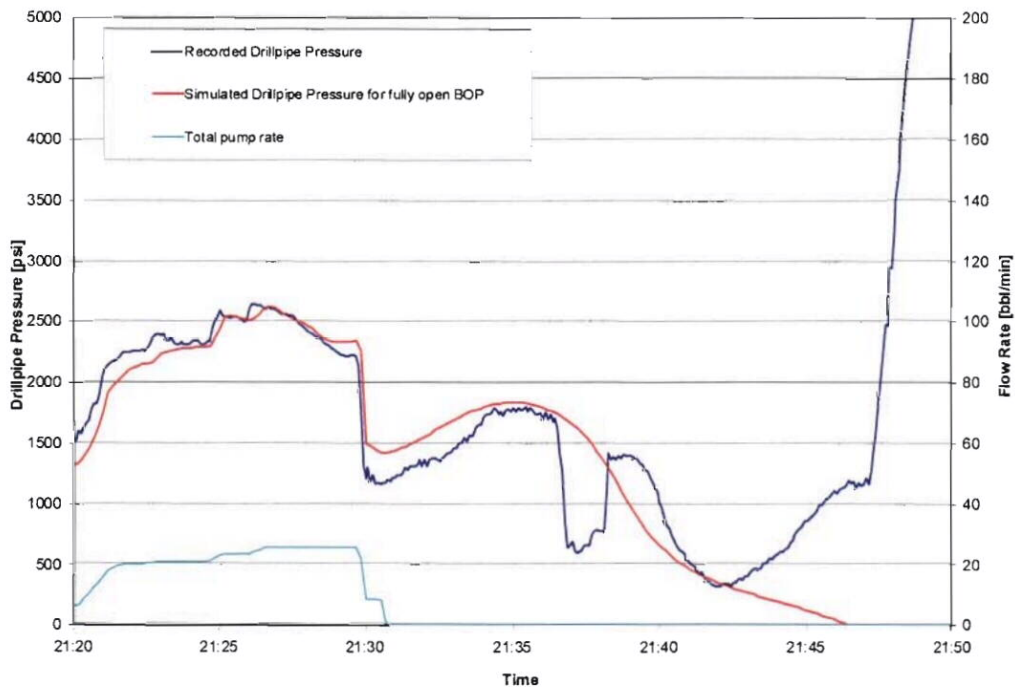

Figure 3.31: Case 7 - Pressure response for simulations without closing BOP (not accounting for the surface bleed)

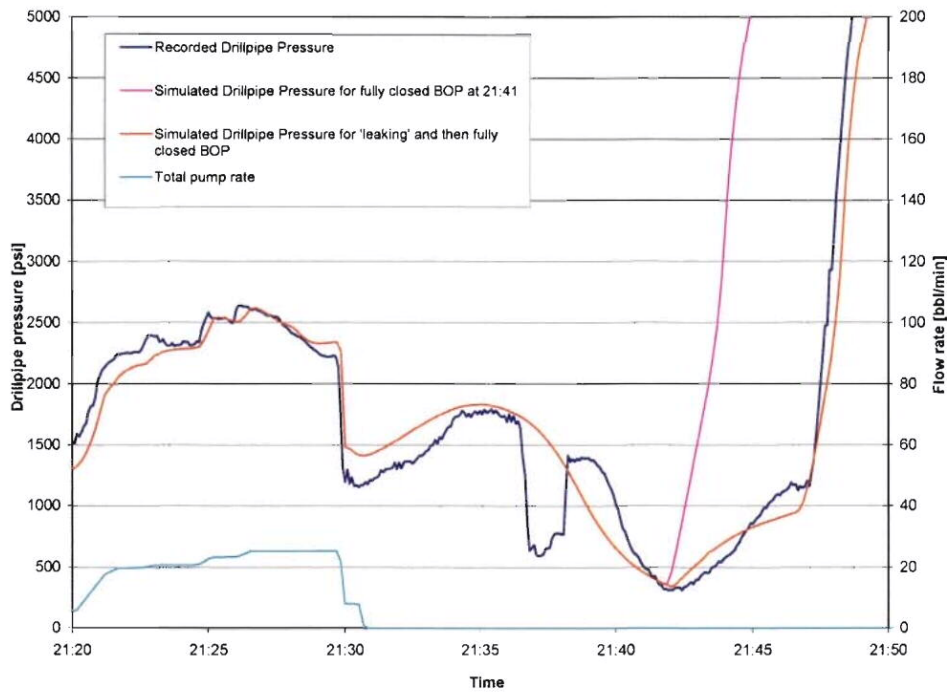

Figure 3.32: Case 7 - Pressure response for simulations with closing annular from 21:41 hrs (not accounting for the surface bleed).

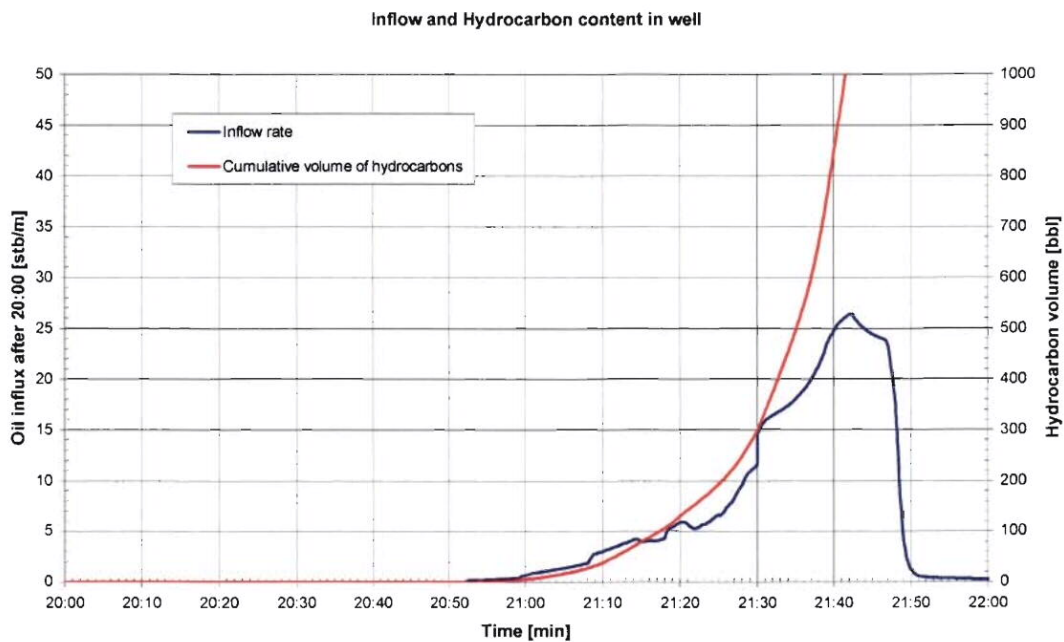

Figure 3.33: Case 7 - Inflow and hydrocarbon volume with closing annular from 21:41 hrs (not accounting for the surface bleed).

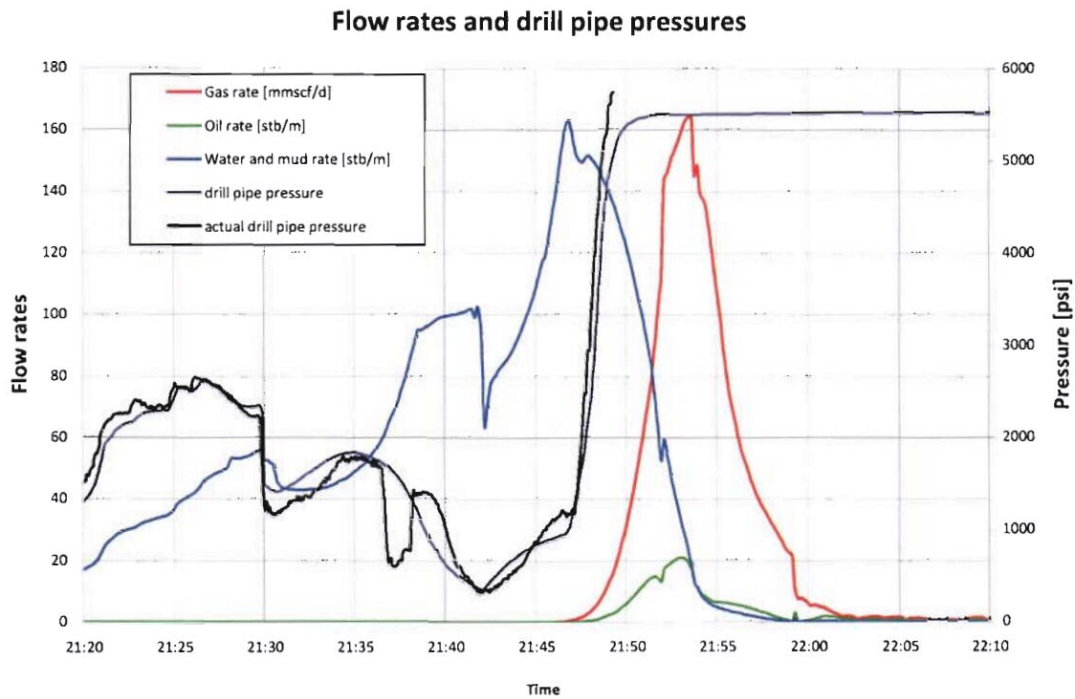

Figure 3.34: Case 7 - Flow and pressure at surface with closing annular from 21:41 hrs (not accounting for the surface bleed).

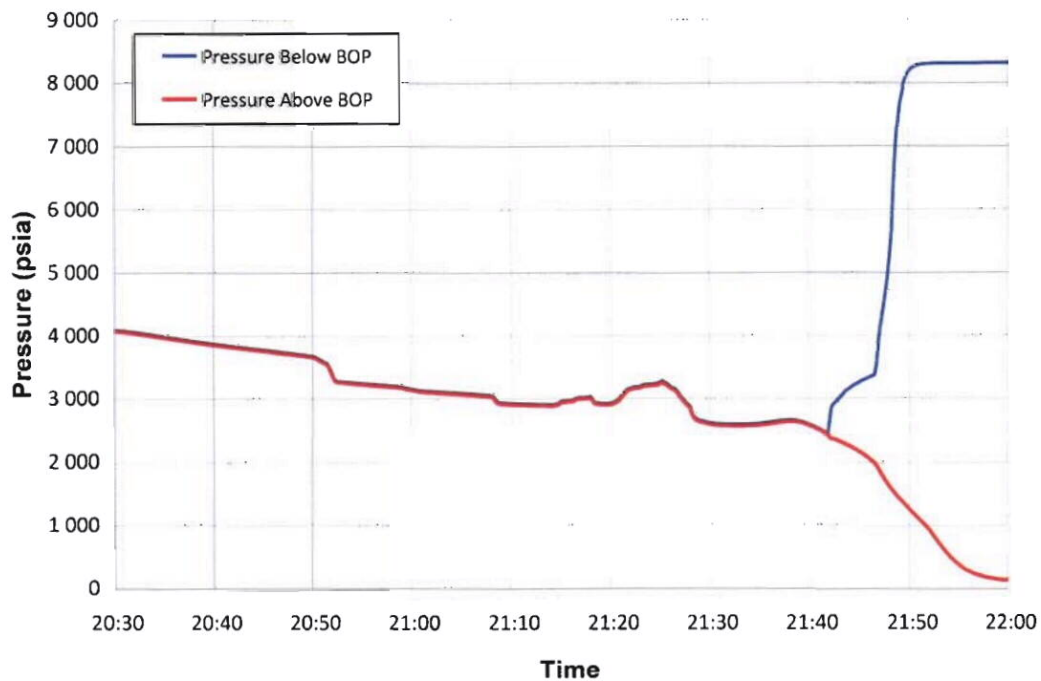

Figure 3.35: Case 7 - Pressure below and above the BOP when closing annular from 21:41 hrs (not accounting for the surface bleed).

3.8 Assumptions and Limitations

The main limitation of the OLGA modeling is the accuracy of the input assumptions. Every effort was made to align the model inputs to ensure a match with the available recorded data and actual events as witnessed. Actual recorded reservoir data for this well was used as an input, this significantly improves the degree of accuracy of the model. The model results should reasonably reflect what actually occurred.

There are other limitations and potential sources of error associated with the model results. One of these sources of error is the numerical diffusion caused by the gridding of the calculation cells, this tends to smear out the liquid fronts. This will have an influence on the transient calculation of the drill pipe pressure. OLGA Slug-tracking is a calculation module made to track these slugs, but the module has not been used as it is not compatible with the Drilling Option required for these calculations.

Further, the simulations include more than the three dedicated phases accepted by OLGA. Both the high viscosity spacer fluid, the 14 ppg mud and water were circulated through the well. All of these fluids are considered to be flowing in the "water phase" of OLGA meaning that they all travel with the same velocity and no swapping and migration is therefore possible.

The spacer is also challenging to model as this is a very viscous, non-Newtonian fluid. Additional pressure drop in the form of a restriction at the outlet was required in order to match the circulation pressures observed.

This report reflects the best judgment and analysis of add energy at the time of writing but with new evidence or assumptions other possible explanations to support the actual events may be plausible.

A. Appendix A



For the dynamic simulations, OLGA-WELL-KILL, (powered by OLGA version 5.3.2 from SPT Group) was applied. The simulator is tailor-made for well kill simulations and has been used in a number of on-site applications for blowout and well control. The development started in 1989 (during an underground blowout in the North Sea) based on the OLGA pipeline simulator. The model is a fully dynamic simulator that is capable of handling three different fluid phases simultaneously. The model is capable of handling non-Newtonian fluids; i.e. the viscosity is depending on the shear-rate. The OWK simulator handles a number of different flow configurations, e.g. annular flow, flow through bit nozzles, valves, pipe joints etc. See www.addenergy.no for more information.

The base core Olga code was presented in 1991 [ref. 14]. The original version of the OLGA-WELL-KILL model is described in a paper from 1996 [ref. 10]. Application of the model have been presented in a number of papers [ref. 1, 2, 4, 8, 11, 12 and 13].



Reservoir fluid characterization and property generation was performed by PVTsim version 19.1. This is the market leading fluid characterization and simulation software. See www.calsep.com for more info.

B. References

1. Oskarsen, Wright, Rygg, Selbekk & Allcorn: "A Case Study in Relief-Well Drilling Using a Modified Driller's Method as a Well-Intervention Alternative to Bullheading." IADC Well Control Middle East 2008 Conference & Exhibition, 2-3 December 2008, Muscat, Oman
2. Rygg, O.B.: "Well control evaluation as an integral part of well design." IADC Well Control Conference Europe, Amsterdam 9-10 April 2008.
3. Scandpower, "Blowout and well release frequencies – BlowFAM Edition.", April 2008.
4. Rygg, O.B.: "The necessity of modelling in contingency planning and emergency well control response." IADC International Well Control Conference & Exhibition, Singapore 8-9 November 2005.
5. OLF "Retningslinjer for beregning av utblåsningsrater og –varigheter til bruk ved analyse av miljørisiko", Nov 2004, Rev.2. Jan. 2007.
6. Reed, M., Emilsen, M. H., Hetland, B. Johansen, Ø, Buffington, S., "Numerical Model for Estimation of Pipeline Oil Spill Volumes", 2003 International Oil Spill Conference, Vancouver, British Colombia, Canada
7. Rygg, O, Emilsen, M. H., "Analysis Of The Hazardous Consequences Of Pipeline Ruptures", PSIG Annual Meeting, October 23-25, 2002, Portland, Oregon
8. Hartmann, R., Møllerstad, H., Bysveen, J. and Rygg, O.B. "Blowout Contingency for Deep Water High Rate Subsea Gas Wells" IADC International Deepwater Drilling Conference, Rio de Janeiro, Brazil, Nov. 2003
9. Holand, Per, "*Offshore Blowouts, Causes and Control*", [Gulf Publishing Company](#), Houston Texas, 1997.
10. Rygg, O.B. Friedemann, J.D. and Nossen, J., "Advanced well flow model used for production, drilling and well control applications." IADC Well Control Conference for Europe, Aberdeen, May 1996
11. Rygg, O.B. and Smestad, P., "Blowout Control Hydraulics applied to Critical well Planning." IADC Well Control Conference for Europe, Stavanger, June 1994
12. Smestad, P., O.B. Rygg and J.W. Wright, "Blowout control: response, intervention and management, Part 5, Hydraulics modelling," World Oil, pp 75-80, April 1994
13. Rygg, O.B.; Smestad, P, and Wright, J.W.: "Dynamic Two-Phase Flow Simulator, a Powerful Tool for Blowout and Relief Well Kill Analysis." SPE 24578, Presented at the 67th SPE Annual Technical Conference and Exhibition, Washington DC, Oct. 1992.
14. Bendiksen, K., Malnes, D., Moe, R. and Nuland, S.: "The Dynamic Two-Fluid Model OLGA: Theory and Application." SPE Production Engineering, May 1991.